



COMMONWEALTH of VIRGINIA

Commonwealth Transportation Board

W. Sheppard Miller, III
Chairperson

1401 East Broad Street
Richmond, Virginia 23219

(804) 482-5818
Fax: (804) 786-2940

COMMONWEALTH TRANSPORTATION BOARD WORKSHOP AGENDA

VDOT Central Office Auditorium
1221 East Broad Street
Richmond, Virginia 23219
June 20, 2023
10:30 a.m.

1. Pedestrian Bridge Over Route 311 for Appalachian Trail
Jo Anne Maxwell, Virginia Department of Transportation
2. I-495 Southside Express Lanes Study
Chris Swanson, Virginia Department of Transportation
3. Revenue Sharing and Transportation Policy Initiatives
Russ Dudley, Virginia Department of Transportation
4. National Electric Vehicle Infrastructure Program Update
Chris Berg, Virginia Department of Transportation
5. FY 2024 - 2029 Commonwealth Transportation Fund Six-Year Financial Plan
Laura Farmer, Virginia Department of Transportation
6. FY2024 Six Year Improvement Program and Budget
Jennifer DeBruhl, Virginia Department of Rail and Public Transportation
7. Final FY 2024 – 2029 Six-Year Improvement Program
Kimberly Pryor, Virginia Department of Transportation
8. SMART SCALE Program Review Updates
Brooke Jackson, Office Intermodal Planning and Investment
9. VTRANS Update
Jitender Ramchandani, Office Intermodal Planning and Investment
10. Director's Items
Jennifer DeBruhl, Virginia Department of Rail and Public Transportation
11. Commissioner's Items
Stephen Brich, Virginia Department of Transportation

Agenda
Meeting of the Commonwealth Transportation Board
Workshop Session
June 20, 2023
Page 2

12. Secretary's Items
Shep Miller, Secretary of Transportation
###



PEDESTRIAN BRIDGE OVER ROUTE 311 FOR APPALACHIAN TRAIL

MEMORANDUM OF AGREEMENT with NPS and supporting entities

SPECIAL USE PERMIT with NPS

| Salem District

June 20, 2023

Project Purpose

- Allow Appalachian Trail (AT) users to cross over Route 311 via a Pedestrian Bridge rather than traverse 311 while under live traffic.
- This section of the AT is used by day hikers accessing the McAfee Knob Trail and Scenic Overview
- The hike sees approximately 50,000 users yearly and is the most photographed section of the Appalachian Trail.
- Currently all AT users are required to traverse route 311 through an on-grade crossing.



Current Route 311 crossing



View atop McAfee Knob

Project Overview

- The bridge spans over Rte. 311 and will give access to the parking area and the Appalachian Trail.
- Project consists of new bridge, retaining walls, and bridge approaches.
- Total project cost of \$3.2 million (HSIP Funded).

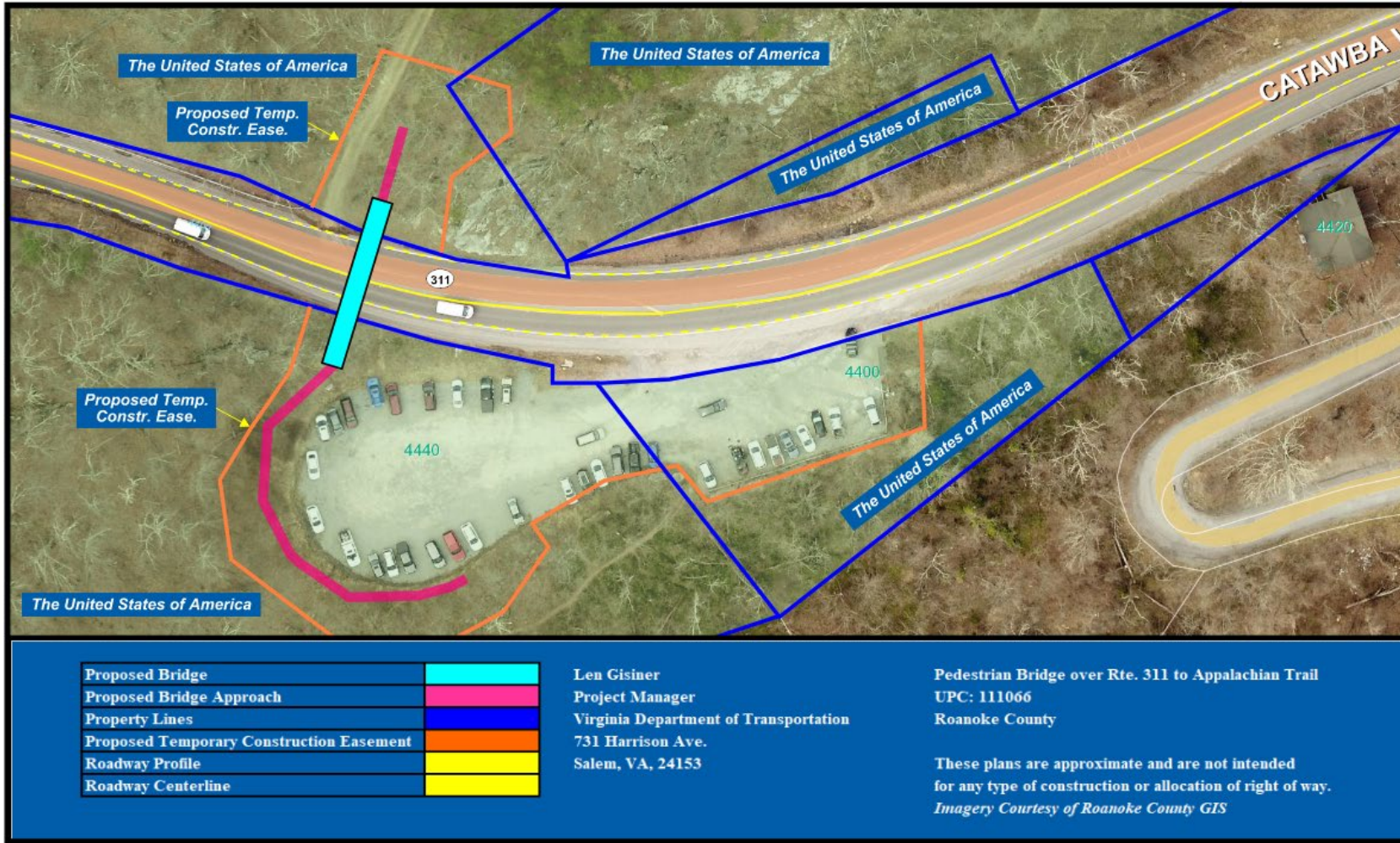

Figure 1. Existing configuration

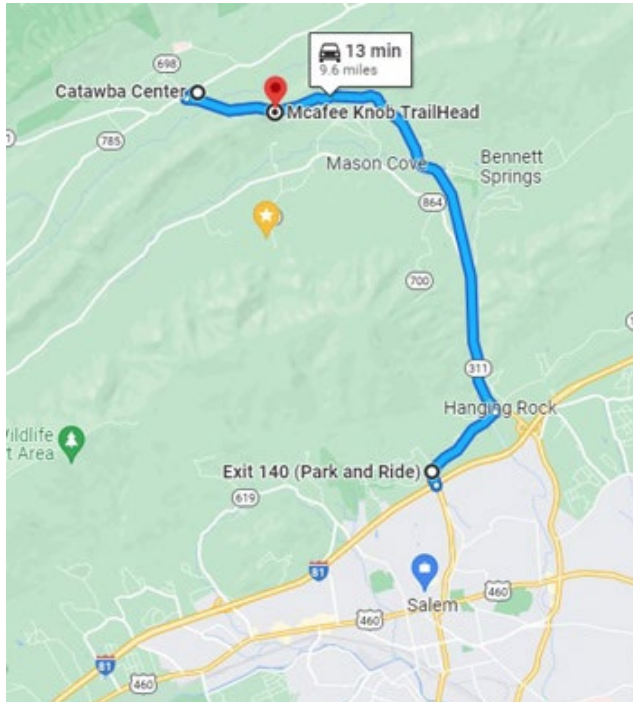

Figure 2. Artistic rendering of proposed bridge

Project Plan



Trailhead Shuttle to McAfee Knob



Shuttle pickup and drop-off location for the AT and McAfee Knob Scenic Trail and Overlook.



Department of Rail and Public Transportation granted funding for the shuttle service after coordination with Roanoke County Officials. Shuttle Service will continue to operate while the parking area is impacted for the construction of the bridge.

Project Schedule

<i>Willingness Process</i>	<i>Complete</i>
Utility relocation	NA
Project advertisement	August 2023
Project award	November 2023
Parking area closes to traffic	November 2023
Bridge opens to pedestrian traffic	October 2024
Project complete	October 2024

Memorandum of Agreement

Purpose

- Establishes the roles and responsibilities for VDOT and the U.S. Department of the Interior, National Park Service, Appalachian National Scenic Trail (NPS-APPA) and the supporting roles of the Appalachian Trail Conservancy and the Roanoke Appalachian Trail Club.

Authority

- Va. Code § 33.2-221(A) provides the CTB with the authority to enter into all contracts or agreements with the United States government

Memorandum of Agreement

Core provisions of the Agreement:

VDOT

- Construct the bridge and convey all rights and responsibilities of ownership to the NPS upon project completion.

NPS - APPA

- Upon completion, assume responsibility of ownership, operation, and maintenance of the structure in a way that does not adversely affect the operation and integrity of Route 311

Memorandum of Agreement

Core provisions of the Agreement – Continued

Recognizing the Supporting Roles of:

Appalachian Trail Conservancy

- Assist the NPS to ensure that the Pedestrian Bridge is inspected by a certified engineer at a cycle not longer than once every four (4) years and in accordance with VDOT's applicable bridge safety inspection standards.

Roanoke Appalachian Trail Club

- Assisting the NPS in performing routine operational maintenance activities on the Pedestrian Bridge including, but not limited to, vegetation clearing, litter removal, and minor graffiti removal.

Special Use Permit

- **National Park Service requires a special use permit granting access to their property for construction**
- **National Park Service has already signed the special use permit**
- **Board approval needed pursuant to Va. Code § 33.2-221(A) prior to Commissioner's signature**



Figure 1. Artistic rendering of proposed bridge

NEXT STEPS

VDOT will seek:

- CTB approval of the Proposed Memorandum of Agreement.
- CTB approval of the Special Use Permit
- CTB delegation of authority for Commissioner to execute the Special Use Permit and Memorandum of Agreement

QUESTIONS



Virginia Department of Transportation

**GENERAL AGREEMENT
AMONG
THE U.S. DEPARTMENT OF THE INTERIOR
NATIONAL PARK SERVICE
APPALACHIAN NATIONAL SCENIC TRAIL
AND
VIRGINIA DEPARTMENT OF TRANSPORTATION
AND
APPALACHIAN TRAIL CONSERVANCY
AND
ROANOKE APPALACHIAN TRAIL CLUB
FOR
MAINTENANCE OF THE PEDESTRIAN BRIDGE CARRYING THE
APPALACHIAN TRAIL OVER VIRGINIA STATE ROUTE 311 (UPC 111066)**

This General Agreement (Agreement) is hereby entered into on the date of last execution below by and among the Virginia Department of Transportation (VDOT), the Appalachian Trail Conservancy (ATC or Partner), the Roanoke Appalachian Trail Club (RATC or Partner), and the U.S. Department of the Interior, National Park Service, Appalachian National Scenic Trail (NPS-APPA) (each a Party and, collectively, the Parties). For the purposes of this Agreement, Partner shall mean ATC and RATC, and shall not include VDOT. Non-Federal entities include all Parties other than NPS-APPA.

ARTICLE I – Background And Objectives:

The purpose of this Agreement is to establish the guidelines for coordination among VDOT, NPS-APPA, ATC, and RATC for the Parties' responsibilities related to the construction and maintenance of the new, grade-separated pedestrian bridge and approaches carrying the Appalachian Trail over Virginia State Route 311 (VA-311) at the McAfee Knob Parking Area in Virginia's Triple Crown (Pedestrian Bridge).

The Appalachian National Scenic Trail (APPA) is a unit within the National Park Service (NPS) tasked with the administration and protection of the Appalachian National Scenic Trail (Trail). The Trail is a pathway that is continuous from Mount Katahdin in Maine to Springer Mountain in Georgia, for travel on foot through the wild, scenic, wooded, pastoral, and culturally significant lands of the Appalachian Mountains. It affords opportunities for backcountry recreation and long-distance hiking that are among the best in the world. Millions of visitors come to the Trail each year, for hikes as short as an afternoon's walk and as long as a five-month trek from Georgia to Maine. The Trail was completed in 1937, and with passage of the 1968 National Trails System Act [P.L. 90-543 (82 Stat. 919), as amended], was designated a national scenic trail. By law, responsibility for administration of the Trail rests with the Secretary of the Interior and is carried out by NPS-APPA. The Trail is preserved for the conservation, public use, enjoyment, and appreciation of the nationally significant scenic, historic, natural, and cultural quality of the areas through which it passes.

The Appalachian Trail Conservancy (ATC) is a non-profit organization that supports NPS-APPA in its administration and protection of the Trail. Its focus includes organizing and mentoring volunteer trail clubs that aid in the day-to-day management and operations of the Trail. Following provisions in the National Trails System Act, ATC works in partnership with NPS-APPA through the 2014 Cooperative

Agreement to manage non-inherently governmental responsibilities for NPS-acquired lands outside existing National Park boundaries.

The Virginia Department of Transportation (VDOT) is responsible for building, maintaining, and operating the Commonwealth's roads, bridges, and tunnels. VDOT's mission is to plan, deliver, operate and maintain a transportation system that is safe, enables easy movement of people and goods, enhances the economy and improves our quality of life. Virginia has the third-largest state-maintained highway system in the country, behind Texas and North Carolina. In totality, VDOT maintains over 50,000 lane miles of highway including the section of VA-311 that intersects with the Trail at an at-grade crossing.

The Roanoke Appalachian Trail Club (RATC) is an independent Virginia 501(c)(3) non-profit organization that is maintaining a club for over 120 miles of the Trail in Virginia, including the section covered by the 2010 *Memorandum of Understanding for the Appalachian National Scenic Trail in the Commonwealth of Virginia*. RATC volunteers build and maintain the Trail and connecting trails, manage 16 shelters on the Trail, and patrol Virginia's Triple Crown (Dragon's Tooth, McAfee Knob, and Tinker Cliffs) as trained volunteer ridge runners. The Local Management Plan for RATC's assigned section of the Trail describes the relationship among the club and other partners such as NPS-APPA, ATC, and the U.S. Forest Service.

ARTICLE II – Legal Authority:

A. For NPS-APPA:

54 U.S.C. § 101101 et seq., and in particular 54 U.S.C. § 101101 – The National Park Service Organic Act -- The Secretary of Interior is authorized to accept donations of land, buildings, or other property within a National Park System Unit.

82 Stat. 919 (1968), 16 U.S.C. §§ 1241-1251 and in particular 16 U.S.C. § 1246(h)(I) --The National Trails System Act -- The Secretary of the Interior is authorized to cooperate with States in the operation and maintenance of National Scenic Trails.

54 U.S.C. § 100101 et seq., General Authority to Take Actions That Promote and Regulate Units of the National Park System -- The NPS Organic Act directs the Secretary of the Interior to “promote and regulate the use of the National Park System by means and measures that conform to the fundamental purpose of the System units, which purpose is to conserve the scenery, natural and historic objects, and wild life in the System units and to provide for the enjoyment of the scenery, natural and historic objects, and wild life in such manner and by such means as will leave them unimpaired for the enjoyment of future generations.”

54 U.S.C. § 102301 -- Acceptance of Volunteer Services -- The Secretary of the Interior is authorized to “recruit, train, and accept ... the services of individuals without compensation as volunteers for or in the aid of interpretive functions or other visitor services or activities in and related to” areas of the National Park System. Such volunteers may not be used for “hazardous duty or law enforcement work or in policymaking processes, or to displace any employee.” A special exception allows the acceptance of the services of individuals that the Secretary determines “are skilled in performing hazardous activities.”

43 U.S.C. § 1473a -- General Authority for NPS to Accept Contributions -- “The Secretary [of the Interior] is authorized to accept lands, buildings, equipment, [and] other contributions, ... and to prosecute projects using such contributions ... in cooperation with other Federal, State or private agencies.”

B. For VDOT:

Va. Code § 33.2-221 authorizes the Commonwealth Transportation Board (CTB) to enter into all contracts or agreements with the United States government and, pursuant to resolution dated [*] and attached hereto as Appendix A, has authorized the Commissioner of Highways to enter into this Agreement.

Va. Code § 33.2-223 authorizes the Commissioner of Highways to do all acts necessary or convenient for constructing, improving, maintaining, and preserving the efficient operation of the highways and charges the Commissioner, as executive head of VDOT, with the duty of executing all orders of the CTB.

ARTICLE III – Responsibilities and Understandings of the Parties:

The Parties agree as follows to perform the functions specified below in accordance with the provisions of this Agreement. Each Party shall be responsible for its own expenses incurred under this Agreement, and nothing contained herein shall be interpreted as obligating any payment by the NPS for goods or services provided by any non-Federal entity.

A. NPS-APPA agrees to:

1. Upon notification by VDOT that construction of the Pedestrian Bridge has been completed and is safe for use, accept ownership of the Pedestrian Bridge into its inventory as an asset of NPS-APPA and accept all responsibilities of ownership thereof on behalf of the United States.
2. Utilize all legally available means to maintain the Pedestrian Bridge in an open, safe, and well-kept manner that does not adversely affect the safe operation or integrity of the VA-311 roadway.
3. Collaborate with the Partners to seek federal funding to support future cyclic maintenance, repair, and rehabilitation needs for the Pedestrian Bridge.
4. Review and approve or deny all proposed third-party agreements of a material nature submitted to NPS-APPA relating to the Pedestrian Bridge.
5. Allow use of NPS-APPA property by the non-Federal entities for the sole and exclusive purpose of achieving the goals and objectives of this Agreement.
6. Once NEPA Compliance is completed and permit approvals are in place grant access to the Project site and all other areas needed by VDOT and/or its contractors for the implementation and oversight of Project construction activities.

B. VDOT agrees to:

1. Continue to own, operate, and maintain the VA-311 roadway and VDOT right of way.
2. Convey to the United States all right, title, and interest in or to the completed Pedestrian Bridge once completed. At the NPS's request, VDOT will execute any documents necessary to confirm the United States' title of the Pedestrian Bridge. VDOT shall retain all other right, title, and interests in the real property unrelated to the transfer of the Pedestrian Bridge structure, including but not limited to the right of way beneath the Pedestrian Bridge in the VA-311 roadway, as depicted and attached hereto as Appendix B.
3. Convey to NPS-APPA a complete set of "as-built" design drawings and copies of all manuals and other documentation pertaining to the Pedestrian Bridge necessary to ensure proper identification, management, maintenance, and repair, including one hardcopy and one electronic copy of final schematic drawings.
4. Provide funding as allocated by the CTB in the Fiscal Year 2023-2028 Six-Year Improvement Program for the implementation of the Project (UPC 111066).
5. Lead the planning and design phase of the Project, with the participation and coordination with NPS-APPA, and manage the construction of the Project in accordance with all applicable federal, state, and local laws and regulations.

C. ATC agrees to assist the NPS with their ownership and maintenance responsibilities by:

1. Maintaining an open, safe, and well-kept Pedestrian Bridge in a manner that does not adversely affect the safe operation or integrity of the VA-311 roadway.
2. Ensuring that the Pedestrian Bridge is inspected by a certified engineer at a cycle not longer than once every four (4) years and in accordance with VDOT's applicable bridge safety inspection standards.
3. Sharing the inspection report produced by the certified engineer as referenced above with all Parties to this Agreement.
4. Ensuring ice and snow removal services are available as needed for the Pedestrian Bridge to comply with the applicable Architectural Barriers Act accessibility standards.

D. RATC agrees to assist the NPS with their ownership and maintenance responsibilities by:

1. Maintaining an open, safe, and well-kept Pedestrian Bridge in a manner that does not adversely affect the safe operation or integrity of the VA-311 roadway.
2. Performing routine operational maintenance activities on the Pedestrian Bridge including, but not limited to, vegetation clearing, litter removal, and minor graffiti removal.

E. NPS-APPA and the non-Federal entities jointly agree to:

1. Work together to collaborate in the planning and design of the Pedestrian Bridge.
2. Participate in regular meetings, to foster close cooperation on implementation of this Agreement.
3. Work together in good faith to resolve differences at the level of the Key Officials listed in this Agreement prior to elevating matters within the Partner organizations or appealing elsewhere within NPS or the federal government.
4. Comply with the terms of applicable laws, regulations, and government policies.
5. Make timely decisions on matters necessary to properly implement and administer this Agreement.
6. Work in good faith to execute other legal instruments needed to supplement this Agreement as necessary to meet the mutual objectives of the Parties. Such agreements may include without limitation Fundraising Agreements, Partnership Agreements, and Cooperative Agreements.
7. Recognize and acknowledge that VDOT shall have no responsibility or obligation to maintain the Pedestrian Bridge in any manner once construction is completed and ownership of the Pedestrian Bridge has been accepted by NPS-APPA pursuant to Section III (A)(1).

ARTICLE IV – Term of Agreement:

This Agreement will run from the date of the final signature until January 1, 2032, unless otherwise terminated earlier in accordance with ARTICLE V.

ARTICLE V – Termination and Expiration:

The Parties may terminate this Agreement at any time by mutual agreement, upon such terms to which they agree and as recited in a written agreement.

ARTICLE VI - Key Officials:

All notices, requests, modifications, and other communications that are required to be in writing, and all concerns regarding the technical implementation and interpretation of this Agreement, shall be personally delivered, emailed, or mailed by certified or registered mail to the persons listed below. All written communications shall be deemed to have been given upon receipt if personally delivered or emailed, or on the fifth business day after mailing. All Parties should be notified if a Key Official changes.

NPS-APPA:

Keith Stegall
NPS-APPA Chief of Facilities
P.O. Box 50
252 McDowell Street
Harpers Ferry, WV 25425
301-712-6729
keith_stegall@nps.gov

Edward Wenschhof
NPS-APPA Superintendent
P.O. Box 50
252 McDowell Street
Harpers Ferry, WV 25425
304-535-6279
ed_wenschhof@nps.gov

ATC:

Andrew Downs
ATC Senior Regional Director - South
416 Campbell Avenue SW, Suite 101
Roanoke, VA 24016
540-904-4354

VDOT:

Kenneth H King, Jr.
VDOT District Engineer
731 Harrison Avenue
Salem, VA 24153
(540) 387-5324
ken.king@vdot.virginia.gov

RATC:

Therese Witcher
RATC Club President
P.O. Box 562
Daleville, VA 24083
540-266-8912

ARTICLE VII – Prior Approval:

The Partners shall obtain prior written approval from NPS-APPA before:

1. Holding special events within the Park;
2. Entering into third-party agreements of a material nature;
3. Assigning this Agreement or any part thereof;
4. Constructing any structure or making any improvements within the Park;
5. Releasing any public information that refers to the Department of the Interior, NPS, NPS-APPA, the Park, any NPS employee (by name or title), this Agreement or the projects contemplated hereunder.

ARTICLE VIII – Liability and Insurance:

The Partners shall indemnify, defend and hold harmless the United States of America and the Commonwealth of Virginia, and their respective agents and employees from and against any and all liabilities, obligations, losses, damages, judgments, claims, actions, suits, penalties, fines, costs and expenses (including reasonable attorneys' fees and experts' fees) of any kind and nature whatsoever arising out of the acts or omissions of the Partners, their respective employees, volunteers, agents or contractors (including any contractor's subcontractors), including injury to persons (including injury resulting in death) and damage to property. The Partners shall promptly pay the United States of America or the Commonwealth of Virginia the full value of all damages to the lands or other property of the United States of America or the Commonwealth of Virginia caused by the Partners, their respective employees, volunteers, agents, representatives, or contractors (including any contractor's subcontractors) or, if agreed to by the Parties, shall undertake the remedial work to repair or replace the damaged lands or property. The Partners will cooperate with NPS-APPA and/or VDOT in the investigation and defense of any claims that may be filed with NPS-APPA and/or VDOT arising out of the activities of the Partners, their employees, volunteers, agents, representatives or contractors (including any contractor's subcontractors).

ARTICLE IX – Right of Inspection and Audit and Annual Work Plan:

- A. Right of Inspection and Audit. The Partners shall permit the Department of the Interior or its designee, including the NPS Comptroller and Office of the Inspector General, to verify and audit any financial audit or records from the books, correspondence, memoranda and other records of the Partners relating to this Agreement or any other agreement executed in connection herewith, during the term of this Agreement and for such time thereafter as may be necessary to accomplish such verification. The Partners agree to take appropriate corrective action based on these audit findings.
- B. Annual Work Plan. Prior to the beginning of each calendar year, the Parties shall jointly develop a written plan (Annual Work Plan) that (1) identifies the projects and programs, including maintenance and inspections, that the Parties agree to undertake in a specific year regarding the Pedestrian Bridge; (2) specifies the respective roles of NPS-APPA and the Partners in carrying out these projects; (3) describes the proposed services the Partners offer to NPS-APPA, if any, in connection with the Pedestrian Bridge and/or identifies any funds the Parties have agreed to set aside for use in future approved projects and/or programs; (4) identifies NPS-APPA's intent, if any, to accept such services to support the Pedestrian Bridge; and (5) defines any other

considerations in accomplishing the intent of this Agreement. The Parties may modify the Annual Work Plan, as appropriate, during the course of the Agreement term by mutually executed amendments.

ARTICLE X – Property Utilization:

All present and future alterations, additions, renovations, improvements, and installations permanently affixed to federally owned land will be owned by the United States.

ARTICLE XI – Intellectual Property:

- A. As used herein, “Intellectual Property” means with respect to a Party, all trademarks, service marks and corporate and brand identification and indicia, including without limitation word marks, logos and other picture marks, video and audio recordings, phrases, composite marks, institutional images, look and feel, images of such Party’s employees, taglines, and web content, in each case, to the extent owned by such party, whether or not such property is trademarked or registered.
- B. No Party to this Agreement shall use any Intellectual Property (as herein described) of the other Party for any purpose (including, without limitation, for collateral marketing, outreach, advertising, or as trade names or internet domain names) without the prior written consent of such other Party, which consent may be withheld in such other Party’s sole discretion. All uses by one Party of the other Party’s Intellectual Property shall be in accordance with any requirements and/or quality control standards (including, without limitation copyright and trademark notices) on which the consenting Party may condition such consent or may promulgate from time to time by notice to the other Party. A Party retains all rights with respect to its Intellectual Property that are not specifically granted to the other Party. Each Party may, in its sole discretion, withdraw its consent to any use of its Intellectual Property by the other Party on five (5) business days’ notice to such other Party. Each Party retains the right to concurrently use, and license others to use, its Intellectual Property anywhere in connection with any purpose.
- C. Each Party agrees that it shall not acquire and shall not claim rights in or title to any Intellectual Property of the other Party.

ARTICLE XII – General Provisions:

- A. Non-Discrimination. All activities pursuant to or in association with this Agreement shall be conducted without discrimination on grounds of race, color, sexual orientation, national origin, disabilities, religion, age, or sex, as well as in compliance with the requirements of any applicable federal laws, regulations, or policies prohibiting such discrimination.
- B. Appropriations.
 - 1. Pursuant to 31 U.S.C. § 1341, nothing contained in this Agreement shall be construed to obligate NPS-APPA, NPS, the Department of the Interior, or the United States of America to any current or future expenditure of funds in advance of the availability of appropriations from Congress and their administrative allocation for the purposes of this Agreement, nor does this Agreement obligate NPS-APPA, NPS, the Department of the

Agreement Number (Park Assigned)

Interior, or the United States of America to spend funds on any particular project or purpose, even if funds are available.

2. All requirements for funds from the Commonwealth of Virginia are subject to appropriation by the General Assembly and allocation by the Commonwealth Transportation Board.
- C. Member of Congress. Pursuant to 41 U.S.C. § 6306, no Member of Congress may enter into or benefit from a contract or agreement or any part of a contract or agreement with the Federal Government.
- D. Lobbying with Appropriated Money. The non-Federal entities will not undertake activities, including lobbying for proposed non-Federal entity or NPS projects or programs, that seek to either (1) alter the appropriation of funds included in the President's budget request to Congress for the Department of the Interior or another federal agency that holds funds for the sole benefit of the NPS under Congressionally authorized programs, including the Federal Lands Highway Program; or (2) alter the allocation of such appropriated funds by NPS or another Federal agency. Nothing in this paragraph is intended to preclude the non-Federal entities from applying for and obtaining a competitive or non-competitive grant of Federal financial assistance from a Federal agency, or from undertaking otherwise lawful activities with respect to any non-Federal entity or NPS activity, project or program included in the President's budget request to Congress. Nothing in this paragraph should be construed as NPS requesting, authorizing or supporting advocacy by non-Federal entities before Congress or any other government official. Except as provided herein and in applicable laws, nothing in this paragraph shall be construed to curtail the non-Federal entity's ability to interact with elected officials.
- E. Drug Free Workplace Act. The non-Federal entities certify that comprehensive actions will be taken to ensure the workplace is drug-free.
- F. Third Parties Not to Benefit. This Agreement does not grant rights or benefits of any nature to any third party.
- G. Assignment, Binding Effect. No Party may assign any of its rights or obligations under this Agreement without the prior written consent of the other Parties. This Agreement shall be binding upon and inure to the benefit of the Parties hereto and their respective successors and permitted assigns. The Parties waive the defense of lack of consideration.
- H. Non-exclusive. This Agreement in no way restricts the Parties from entering into similar agreements, or participating in similar activities or arrangements, with other public or private agencies, organizations, or individuals.
- I. Compliance with Applicable Laws. This Agreement and performance hereunder is subject to all applicable laws, regulations and government policies, whether now in force or hereafter enacted or promulgated. Nothing in this Agreement shall be construed as (i) in any way impairing the authority of the NPS-APPA to supervise, regulate, and administer its property under applicable laws, regulations, and management plans or policies as they may be

modified from time-to-time or (ii) inconsistent with or contrary to the purpose or intent of any Act of Congress.

- J.** Disclaimers of Government Endorsement. The non-Federal entities will not publicize or circulate materials (such as advertisements, solicitations, brochures, press releases, speeches, pictures, movies, articles, manuscripts, or other publications), suggesting, expressly or implicitly, that the that the United States of America, the Department of the Interior, NPS, NPS-APPA, or any government employee endorses any business, brands, goods or services.
- K.** Public Release of Information. The non-Federal entities must obtain prior written approval through the NPS-APPA Key Official (or his or her designee) for any public information releases (including advertisements, solicitations, brochures, and press releases) that refer to the Department of the Interior, any bureau, park unit, or employee (by name or title), or to this Agreement unless such releases of public information are otherwise required by law. The specific text, layout, photographs, etc., of the proposed release must be submitted with the request for approval. NPS-APPA will make a good-faith effort to expeditiously respond to such requests.
- L.** Merger. This Agreement, including any attachments hereto, and/or documents incorporated by reference herein, contains the sole and entire agreement of the Parties.
- M.** Modification. This Agreement may be extended, renewed, or amended only when agreed to in writing by all Parties.
- N.** Waiver. Failure to enforce any provision of this Agreement by any Party shall not constitute waiver of that provision. Waivers must be express and evidenced in writing.
- O.** Counterparts. This Agreement may be executed in counterparts, each of which shall be deemed an original (including copies sent to a party by facsimile transmission) as against the Party signing such counterpart, but which together shall constitute one and the same instrument.
- P.** Agency. The non-Federal entities are not agents or representatives of the United States, the Department of the Interior, NPS, or the NPS-APPA, nor will the non-Federal entities represent themselves as such to third parties.
- Q.** Survival. In addition to any other provision herein explicitly providing for survival, any and all provisions that, by themselves or their nature, are reasonably expected to be performed after the expiration or earlier termination of this Agreement shall survive and be enforceable after the expiration or earlier termination of this Agreement. Any and all liabilities, actual or contingent, that have arisen during the term of this Agreement and in connection with this Agreement shall survive expiration or termination of this Agreement.
- R.** Partial Invalidity. If any provision of this Agreement or the application thereof to any Party or circumstance shall, to any extent, be held invalid or unenforceable, the remainder of this Agreement or the application of such provision to the Parties or circumstances other than those to which it is held invalid or unenforceable shall not be affected thereby, and each

provision of this Agreement shall be valid and be enforced to the fullest extent permitted by law.

- S. Captions and Headings. The captions, headings, article numbers, and paragraph numbers and letters appearing in this Agreement are inserted only as a matter of convenience and in no way shall be construed as defining or limiting the scope or intent of the provisions of this Agreement nor in any way affecting this Agreement.
- T. VDOT Appropriations. Obligations of VDOT pursuant to this Agreement are subject to appropriation by the General Assembly and allocation by the Commonwealth Transportation Board.

ARTICLE XIII – ATTACHMENTS

[Appendix A—Resolution of the Commonwealth Transportation Board authorizing the Commissioner’s execution of the Agreement]

Appendix B—Site Depiction

ARTICLE XIV – SIGNATURES

IN WITNESS HEREOF, the Parties hereto have signed their names and executed this Agreement on the dates indicated below.

**U.S. DEPARTMENT OF THE INTERIOR, NATIONAL PARK SERVICE
APPALACHIAN NATIONAL SCENIC TRAIL**

Date _____
Edward Wenschhof
NPS-APPA Park Superintendent

APPALACHIAN TRAIL CONSERVANCY

Date _____
Sandra Marra
ATC President & CEO

ROANOKE APPALACHIAN TRAIL CLUB

Date _____
Therese Witcher
RATC Club President

VIRGINIA DEPARTMENT of TRANSPORTATION

Date _____

Stephen C. Brich, P.E.
Commissioner of Highways

DRAFT

SPECIAL USE PERMIT



Appalachian National Scenic Trail
252 McDowell Street / PO Box 50
Harpers Ferry, WV 25425
304-535-6278



Permittee information
Permittee name: Matt Southall (Permittee)
Company/Organization: Virginia Department of Transportation
Street address: 1401 East Broad Street
City: Richmond
State: Virginia
Country: USA
Zip code: 23219
Mobile phone number: 804-396-0684
Fax number:
Email address: Matthew.Southall@VDOT.Virginia.gov

Park alpha code: APPA

Permit # 2490-2700-2301

Type of use:

- Special event
- filming or still photography
- Demonstration, sale or distribution of printed matter, etc.
- Agricultural or grazing
- Other: Construction

NEPA compliance:

- Categorically excluded
- EA/FONSI
- EIS
- PEPC # 113688
- Other

Authorizing legislation or other authority:

- 54 U.S.C. § 100101
- 54 U.S.C. § 100751(a)
- 54 U.S.C. § 103104
- 54 U.S.C. § 100905 (still photography)
- Other authority:
- Park-specific legislation: Public Law (90-543, 82 Stat.919)

The Permittee is authorized to use the following described lands or facilities on the Appalachian National Scenic Trail (ANST or Park): Four areas totaling 34,707-square feet marked and described on the final approved project plan set as temporary construction easement (Permitted Area).

The Permittee may use those lands or facilities only for the following purpose: Installation of a pedestrian bridge with accessibility ramp/sidewalk and stairs that will carry the Appalachian National Scenic Trail across Route 311. This permit begins when signed by all parties and expires at 6:00 pm on October 4, 2024.

Application fee	Received _____	Not Required <u>X</u>	Amount \$ _____
Performance bond	Received _____	Not Required <u>X</u>	Amount \$ _____
Liability insurance	Received _____	Not Required _____	Amount \$ 1million /3million
Cost recovery	Received _____	Not Required <u>X</u>	Amount \$ _____
Location fee	Received _____	Not Required <u>X</u>	Amount \$ _____
Other authorized fee	Received _____	Not Required <u>X</u>	Amount \$ _____

Issuance of the permit is subject to the below-listed general and park-specific terms and conditions. The undersigned hereby accepts this permit subject to those terms and conditions and agrees to be bound by them.

Permittee signature

Title:
Acting Superintendent

Date:
May 30, 2023

Authorizing NPS official

Title:

Date:

General Terms and Conditions

1. The Permittee must perform the work or conduct the activities authorized by this permit in accordance with the permit's terms and conditions and in accordance with all applicable federal, state, or local law, including the regulations in 36 C.F.R. chapter I; the regulations in 43 C.F.R. part 5; and all applicable workplace-safety and public-health orders, rules, and requirements. If the Permittee fails to do so, then the Superintendent of the Appalachian National Scenic Trail (Superintendent) may immediately suspend or revoke this permit without notice.
2. The Superintendent may immediately suspend or revoke this permit without notice if destruction of, loss of, or injury to any park property or resource has occurred, is occurring, or appears imminent. In accordance with the System Unit Resource Protection Act, 54 U.S.C. §§ 100721-100725, any person that destroys, causes the loss of, or injures any park system unit resource will be liable to the United States for response costs and damages resulting from the destruction, loss, or injury.
3. The Superintendent may revoke this permit at any time after providing 24 hours' written notice to the Permittee setting forth the reasons for the revocation.
4. If this permit is revoked for any reason or upon its expiration, the Permittee must repair all damage to park property or resources in accordance with the Superintendent's direction and must restore the Permitted Area to its original, pre-permit condition.
5. The Permittee must obtain all federal, state, or local permits, licenses, inspections, or other reviews or approvals legally required to perform the permitted work or conduct the permitted activities.
6. This permit does not grant the Permittee exclusive use of the Permitted Area. Unless the Superintendent restricts public access to or closes the Permitted Area in accordance with 36 C.F.R. § 1.5, the Permitted Area will remain open to the public to the same extent that it is open to the public during regular park visiting hours, and the permitted work or activities may not unduly interfere with the public's use and enjoyment of the Permitted Area.
7. This permit may not be transferred or assigned to another party without the Superintendent's prior written approval.
8. The Permittee waives all demands, claims, and causes of action against the United States and its officers, employees, agents, and representatives, and releases the United States and its officers, employees, agents, and representatives from all liability, arising out of or resulting from the permitted work or activities. The National Park Service issues this permit upon the express condition that the United States and its officers, employees, agents, and representatives will be free from all liability of any sort whatsoever arising out of or resulting from the permitted work or activities. Accordingly, the Permittee hereby agrees to indemnify, defend, and save and hold harmless the United States and its officers, employees, agents, and representatives from and against all liability of any sort whatsoever arising out of or resulting from the permitted work or activities.
9. To the extent that work undertaken on NPS lands is performed by other than Virginia Department of Transportation (VDOT) employees, VDOT shall require such person(s) or corporation(s) to:
 - a. Procure public and employee liability insurance against claims occasioned by the action or omissions of its agents and employees in carrying out the activities and operations authorized by this permit. The policy shall be in the amount of one (1) million dollars (\$1,000,000) per occurrence and three (3) million dollars (\$3,000,000) aggregate; must be issued by a company licensed to do business and in good standing in Virginia; and must name the United States of America as additional insured.
 - b. Pay the United States the full value for all damages to the lands or other property of the United States caused by the said person or organization, its representatives, or employees.
 - c. Indemnify, save and hold harmless, and defend the United States against all fines, claims, damages, losses, judgments, and expenses arising out of, or from, any omission or activity of the said person or organization, its representatives, or employees.
10. Permittee shall provide the Superintendent with a Certificate of Insurance with the proper endorsements before the permit's effective date.

11. If the Superintendent requires a bond as a condition of issuing this permit, then the Permittee must deposit with the Park, before the effective date of this permit, a bond in the amount of \$ _N/A_ from a bonding company licensed to do business and in good standing in Virginia or in the form of cash or cash equivalent, to guarantee that all financial obligations to the Park will be satisfied.

12. As authorized by 54 U.S.C. § 103104 or 54 U.S.C. § 100905 and in accordance with other applicable law and policy, the National Park Service will recover all costs of providing necessary services associated with this permit, including the costs of administering the permit and monitoring the permitted work or activities. The National Park Service may bill the Permittee for either actual costs or estimated costs. Payment is due at the time of billing. If the National Park Service bills the Permittee for estimated costs, and actual costs exceed the estimated amounts, then the National Park Service will bill the Permittee for the excess. If the National Park Service bills the Permittee for estimated costs, and actual costs are less than the estimated amounts, then the National Park Service will refund the difference to the Permittee after the permitted work or activities have concluded and the permit has expired or been terminated. Under no circumstances will the National Park Service be liable for interest on any refunded amount.

13. The Permittee designates Tony Handy, Salem District VDOT, 540-352-9050, as the on-site person responsible for adherence to the permit's terms and conditions. The on-site person must have full authority to make all decisions about the permitted work or activities; must be reachable at all times; and is responsible for all persons or entities performing the permitted work or activities, including the Permittee's contractors and subcontractors.

14. Nothing in this permit binds the National Park Service to expend in any one fiscal year any sum in excess of appropriations made by Congress or allocated by the National Park Service for the purpose of this permit, or to involve the National Park Service in any contract or other obligation for the further expenditure of money in excess of such appropriations or allocations.

15. If any provision of this permit is found to be invalid or unenforceable, the remaining provisions of this permit will not be affected and may be enforced to the full extent authorized by applicable law.

16. Use of the National Park Service Arrowhead Symbol is governed by 36 C.F.R. part 11. The Arrowhead Symbol is the official emblem and a registered trademark of the National Park Service. The National Park Service must authorize any use of the Arrowhead Symbol, including incidental use. Using the Arrowhead Symbol for advertising, promotional, or other commercial purposes is prohibited. Unauthorized use of the Arrowhead Symbol may subject an individual to criminal penalties under 18 U.S.C. § 701.

17. Approval of the special use permit does not constitute and should not be construed as a Government endorsement of the permittee's views, activities, products, goods, services, or enterprise. The permittee shall not refer to special use permits awarded by the National Park Service for commercial purposes, in advertising, or in a manner which states or implies that, by issuing the special use permit, the views, activities, products, goods, services, or enterprises undertaken pursuant to this permit are approved of or endorsed by the Government.

18. Credit Lines may be approved through additional terms and conditions.

19. Federal regulations prohibit any person from knowingly giving false information on an application for a permit and from knowingly giving a false report for the purpose of misleading a government employee or agent in the conduct of official duties. 36 C.F.R. §§ 2.32(a)(3) and 2.32(a)(4). Any violation of those regulations will result in this permit's immediate revocation.

Park-specific Terms and Conditions

20. This Special Use Permit numbers seventy-two (72) pages and contains four (4) Exhibits. Exhibit A: Bridge Design Plans; Exhibit B: Construction Plans; Exhibit C: ANST Plan for Inadvertent Discoveries, and Exhibit D: Fire Road Closure.

21. The National Park Service (NPS) Permit Coordinator for this Permit is Denise Nelson, Environmental Protection Specialist, 301-512-5573 (cell), denise_nelson@nps.gov. Permittee shall notify the Permit Coordinator at least three (3) business days before the start of Permitted activities to alert NPS of the initiation of Permitted work and provide a schedule of planned activities. Permittee shall also notify the Permit Coordinator of work completion within twenty-four (24) hours of completing Permitted activities. Other NPS contacts for this Permit include:

- a. Keith Stegall, Chief of Facilities Maintenance, 301-712-6729 (cell) keith_stegall@nps.gov
- b. Brian Wilson, Park Ranger, 540-529-3312, brian_d_wilson@nps.gov

22. Status Reports - From the commencement of construction activities on NPS lands, the Permittee will provide updated project status reports on a quarterly basis until all construction-related activities including restoration is completed on NPS lands. The Permittee will provide a copy of these status reports to the three NPS contacts listed above.
23. NPS may monitor the work while in progress and conduct a site inspection following work completion.
24. Permittee is responsible for ensuring that its officers, employees, representative, agents, contractors, and subcontractors are familiar with this Permit and comply with its terms and conditions. All supervisory personnel working for the Permittee within the Permitted Area must carry a copy of this Permit, with at least one (1) copy of the Permit on site at all times. This Permit must be presented to NPS officials upon request. Failure to present this Permit may result in permit activities being suspended.
25. NPS approval of this Permit is based on information provided in the application and supplemental information provided by the Permittee in support of the application. A copy of the reference project design and construction plan documents provided with the application is included in Exhibits A and B. Any proposed changes to the project or permitted activities following permit issuance must be approved by the Superintendent at least one week prior to implementation. Any alterations to this Permit must be in writing and signed by the parties and is subject to additional impacts analysis prior to approval.
26. Permittee is authorized to install a pedestrian bridge and associated sidewalk/ramp and stairs. Permittee is authorized to install drainage and erosion control measures including a minor shift of the drainage channel along the edge of the parking lot, conduct tree clearing and grubbing, excavate and grade soils, apply riprap with a geotextile fabric underlayment to slopes, stage equipment and materials, install temporary construction fencing and signs, add gravel to the parking lot, and reseed to restore the site. All work on NPS land is limited to and shall be in accordance with the project controlling documents including the final construction plans and required permits. Any field adjustments or construction plan revisions shall be reviewed by the NPS Permit Coordinator prior to work proceeding.

Equipment and Materials

27. Support equipment to be used as estimated at the time of application includes: One (1) 30T crane, two (2) excavators (CAT 315 and 325), one (1) 20-foot tool storage, one (1) portable field office/storage shed, one or two (1-2) portable toilets, one or two (1-2) dumpsters, and staff vehicles. Permittee shall send the NPS Permit Coordinator a list of equipment to be used once acquired by the selected contractor(s) and prior to initiating work.
28. Staging of equipment, materials, and vehicles shall occur on already disturbed land and is restricted to the staging area of the parking lot shown in Exhibit B: Erosion and Sediment Control Plan. Permittee equipment shall be properly secured if left on-site overnight.
29. Permittee shall refuel or store fuel off NPS lands whenever feasible. Permittee may refuel on NPS lands when necessary at locations as far away from the spring along the edge of the parking area as practical and with proper spill containment and preventative measures found within a refuel/spill containment plan. Permittee shall have spill kits and appropriate containment available for all machinery and containers holding fuels, oils, or other chemicals. In the event of a fuel or oil leak/spill within the Park, work shall immediately cease, spill containment be deployed, and the spill reported to NPS and state authorities as required. The Virginia Department of Environmental Quality Pollution Response Department shall be called immediately at 540-574-7800. The Permittee shall be responsible for any required remediation measures such as removing contaminated soil from the site.
30. Engines shall be shut off when not in use, i.e. no idling allowed.
31. Means of extinguishing a fire shall be available on site at all times. Permittee shall do everything reasonably within its power to prevent and suppress fires resulting from the Permittee's activities on and adjacent to the Permit area.
32. All Permittee equipment and hand tools that come into contact with Park soil shall be free of dirt, seeds and vegetation prior to entering the Park. Frames, tires, tracks, beds, buckets and other attachments must be pressure washed or steam cleaned. Vehicles and equipment are to be cleaned offsite and off NPS lands. Attention shall be shown to the under carriage and any surface where soil containing exotic seeds may exist like cracks, crevices and tire treads.
33. The transport of sediment onto paved or public roads at access entrances shall be minimized. Whenever vehicle tracking of sediment occurs, sediment shall be removed daily by shoveling or sweeping.

Safety

34. Permittee is responsible for all necessary safety equipment and industry standard construction practices. This includes all necessary signs, fencing, and other measures needed to ensure persons not associated with this permit are kept out of the construction zone and safely away from construction hazards.

35. Permittee and its contractor(s) shall follow their respective safety protocols and plans. Any safety violations shall be corrected immediately. If the violation is not corrected immediately, the project shall be suspended until such corrections are made.

36. In the case of an OSHA-reportable injury, criminal incident, spill, or environmental emergency within the Permitted Area involving the Project, the Permittee or its officers, employees, representatives, agents, contractors, or subcontractors, Park employees or visitors, the Permittee shall notify the NPS within two (2) hours of the event by contacting NPS Dispatch at 866-677-6677 and NPS Permit Coordinator, Denise Nelson, 301-512-5573 (cell). The Permittee must also submit to the Superintendent within forty-eight (48) hours a full written report of actions and corrections taken and submit a complete report including the resolution of the situation within ninety (90) days.

37. Permittee shall maintain safe and continued passage of hikers and visitors through the project area. Permittee shall:

- a. Inform all its representatives and contractors of the location of the Appalachian Trail, the shuttle pull-off area for loading and unloading visitors, and of the safety protocols required to ensure Park visitor safety.
- b. Install fencing to guide visitors safely around the construction area.
- c. Install temporary signs on the trail to warn visitors about the work areas ahead. Signs shall be placed along the Appalachian Trail on either side of the work zone before work begins and removed upon project completion.
- d. Implement all measures in the traffic management plan [See Exhibit B].

38. The Fire Road between Route 311 and its intersection with the McAfee Knob Fire Road Connector Side Trail north of Route 311 will be closed to the public with signage and barrier during construction but shall remain accessible by emergency personnel [See Exhibit D]. Permittee shall ensure that equipment and materials do not block emergency vehicle access to the Fire Road.

39. The gravel parking lot will be gated and closed to the public during construction. Permittee shall maintain and control entrance through the construction entrance gate to the parking lot. As outlined in the transportation management plan, Permittee shall provide local emergency response organizations with access to the locked emergency vehicle entrance gate prior to commencing work. Permittee shall notify NPS ANST Chief of Facilities Keith Stegall at least thirty (30) days before the parking lot is closed to the public.

Operations

40. Permittee shall complete work onsite during daylight hours to the greatest extent possible and use minimum lighting required to safely conduct work at night when necessary for beam setting.

41. Permitted activities shall not occur during severe weather conditions and permitted activities involving ground disturbance shall not occur during saturated soil conditions.

42. Work areas shall be maintained in a sanitary condition at all times and waste materials shall be disposed of promptly at an approved waste disposal site.

43. Permittee is authorized to cut and remove trees and other vegetation as follows:

- a. Tree removal is limited to that specified in the project plans and Permittee shall avoid collateral damage to trees and other vegetation not slated for removal including gashing of adjacent trees.
- b. Trees may be cut outside the active bat season only. [Trees may be cut from November 15th through March 31st. No trees may be cut from April 1 through November 14th]. Note: this restriction is also protective of the state endangered songbird the Loggerhead Shrike.
- c. Limits of the tree clearing area must be clearly marked in the field prior to any tree clearing.
- d. Permittee shall ensure contractor(s) conducting the tree clearing understand the clearing limits and how they are marked in the field.

- e. Tree roots may be removed only where required [See Exhibit B: Erosion and Sediment Control Plan Sheets].
- f. For any tree pruning, make clean cuts at the base of branches without damaging the tree trunk or branch collar. Do not rip, tear, or pull live branches.
- g. For any trees cut but not grubbed, stumps shall be cut low (less than 6" from the ground) unless there are rocks or other material that would prevent a low stump cut.
- h. Cut vegetation shall be removed from the site or left to lie on the forest floor to facilitate decay. Woody debris left to decay on-site shall be cut into lengths of no more than eight (8) feet and spread out and away from the Appalachian Trail treadway and not piled or windrowed.

44. Permittee shall take measures necessary to ensure trees and other vegetation on NPS land outside the Permitted area are not damaged by project activities.

45. Permittee shall limit all ground disturbance to within the project Limits of Disturbance (LOD) shown in Exhibit B: Erosion and Sediment Control Plan Sheet No. 5. The exterior boundaries (not including the boundary along the paved roadway) shall be clearly marked and posted prior to construction and maintained during any surface disturbing activities. Land disturbance within the LOD shall be conducted in a manner that minimizes disturbance and preserves topsoil especially on steep slopes, minimizes erosion, and minimizes soil compaction outside the bridge footprint.

46. Permittee shall install temporary silt fence as outlined in the final construction plans [See Exhibit B: Environmental Commitments Summary Sheet and Erosion and Sediment Control Plan Sheets]. All installed erosion and sediment control measures shall be inspected and maintained as outlined in the final construction plans and per applicable federal and state regulations and removed only after the site has been revegetated and restored.

47. Disturbed areas shall be reseeded as soon as possible with a native seed mix and covered with certified weed-free straw. The native seed mix will include only plants native to the project area in Roanoke County, Virginia.

48. Permittee shall avoid impacting the rockshelter located near the bridge north abutment and stairs. This cultural feature shall be inspected daily during installation of the north abutment and the NPS Permit Coordinator notified immediately if any damage is noted such as new fissures or cracks in the rock.

49. Permittee will ensure the bridge is constructed as designed including specified architectural treatments and colors to help it blend in with the natural surroundings of the ANST.

50. Permittee is responsible for the removal of all trash and construction debris upon completion of permitted project activities. Permittee shall inspect the site to confirm all debris, waste, litter, and spoils have been removed from the project area.

Inadvertent Discovery

51. Permittee shall halt any activities and notify the Park Cultural Resources Manager, Joel Dukes at 978-970-5143 (office) or 617-429-4468 (cell) immediately upon discovery of human remains, or archeological, paleontological, or historical findings. Clearance to proceed shall only be allowed under the condition that if concealed archeological resources are encountered during project activities; all necessary steps will be taken to protect them. Permittee agrees and understands that all artifacts unearthed on Park property shall remain the property of the Park. See Exhibit C – Appalachian National Scenic Trail Plan for Inadvertent Discoveries for additional requirements and instructions.

52. Permittee shall halt any activities and notify the NPS Permit Coordinator immediately upon discovery of threatened or endangered species. The NPS will advise about next steps and when work may proceed.

Damages and Restoration

53. Permittee shall restore NPS areas impacted by construction and outside the bridge footprint

54. Permittee shall repair any damage to Park property and physical resources caused by or occurring incident to Permitted activities to the satisfaction of the Superintendent or their representative within fourteen (14) days of work completion, or if repair is not possible, shall provide monetary compensation for the damages. Repair and restoration activities may include but are not limited to ensuring proper drainage of disturbed areas, filling in ruts or holes in the parking lot or Fire Road, replacing lost gravel in the parking lot, replacing any damaged boundary markers or monuments, and reseeding disturbed areas.

55. Permittee is responsible for any damages to non-Federal property, such as but not limited to vehicles and utilities in the general area of this permit. Any utilities which are damaged or disrupted during construction or restoration process shall be immediately repaired or restored.

Exhibit A

Bridge Design Plans

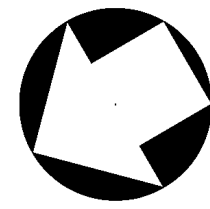

STATE	FEDERAL AID	STATE	SHEET NO.
VA.	PROJECT HSIP-080-2(031)	ROUTE PROJECT 311 0311-080-913, B618	1
Federal Structure No. 00000000030973		FHWA Construction and Scour Code: X231-SN	
Federal Stewardship and Oversight Code: NFO		UPC No. 111066	

DESIGN EXCEPTION(S):

None

GENERAL NOTES:

The original approved sheet, including original signatures, is filed in the VDOT Central Office. Any misuse of electronic files, including scanned signatures is illegal. Violators will be prosecuted to the full extent of the applicable laws.

Width: 8'-0" face-to-face of parapets.

Span Layout: 90'-0" steel beam span

Capacity: 90 psf pedestrian loading

Specifications:

Construction: Virginia Department of Transportation Road and Bridge Specifications, 2020.

Design: AASHTO LRFD Bridge Design Specifications, 8th Edition, 2017; and VDOT Modifications.

LRFD Guide Specifications for Design of Pedestrian Bridges 2nd Edition, 2009; and VDOT Modifications.

Standards: Virginia Department of Transportation Road and Bridge Standards, 2016; including all current revisions.

These plans are incomplete unless accompanied by the Supplemental Specifications and Special Provisions included in the contract documents.

Design loading includes 20 psf allowance for construction tolerances and construction methods.

Design loading includes 15 psf allowance for future wearing surface.

All structural steel, including bearings, shall be ASTM A709 Grade 50W and shall be unpainted.

Concrete in superstructure and parapets shall be Low Shrinkage Class A4 Modified in accordance with Section 217.12(a); in substructure and retaining walls, Class A3.

Permeability testing does not apply to this project.

Concrete surface color coating for bridge railings, abutments and retaining walls shall be Dark Gray, similar to Federal Standard Color No. 595-36492.

Metal stairs, hand rails and pedestrian fencing shall be Brown, similar to Federal Standard Color No. 595-20059.

All reinforcing steel shall be deformed and shall conform to ASTM A615 Grade 60 except for steels noted as Corrosion Resistant Reinforcing (CRR) which shall conform to Section 223 of the Specifications. All reinforcing bar dimensions on the detailed drawings are to centers of bars except where otherwise noted and are subject to fabrication and construction tolerances.

General Notes continued on sheet 2.



**COMMONWEALTH OF VIRGINIA
DEPARTMENT OF TRANSPORTATION
PROPOSED PEDESTRIAN BRIDGE**

**OVER ROUTE 311 (CATAWBA VALLEY DR)
ROANOKE COUNTY
PROJECT 0311-080-913, B618**

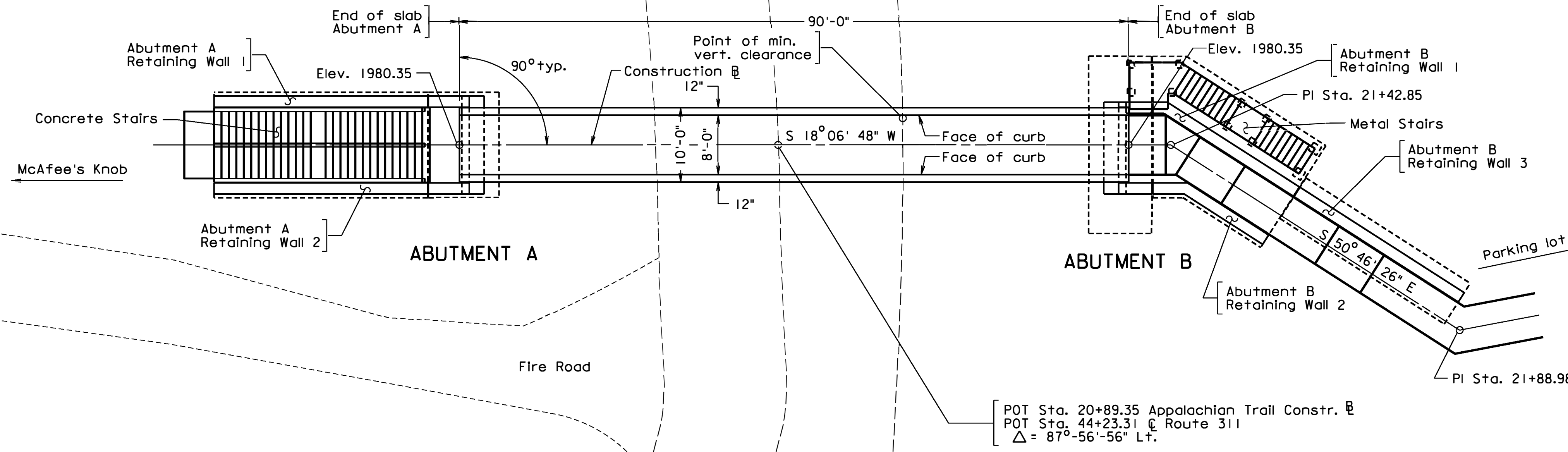

PLAN

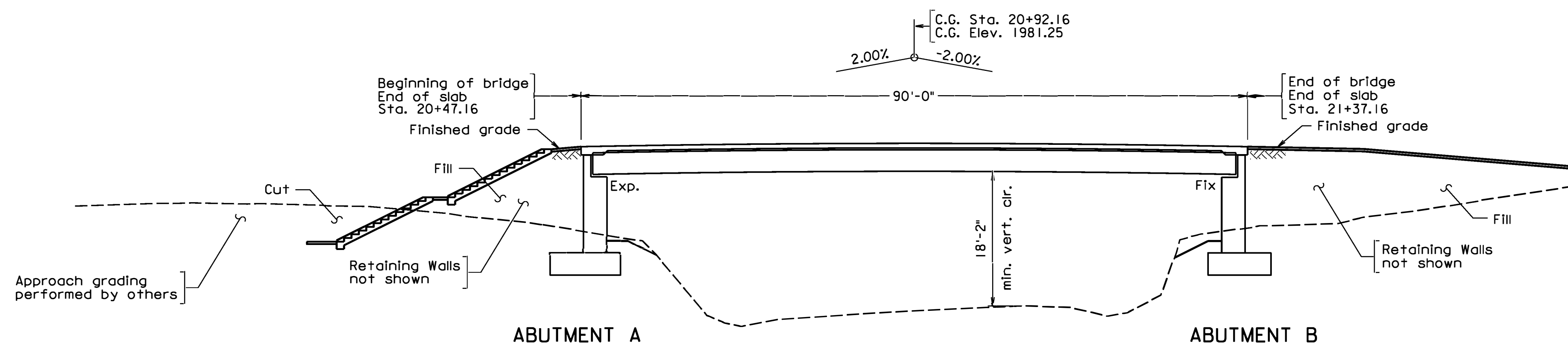

DEVELOPED SECTION ALONG B-B

Recommended for Approval: _____ Date _____
District Planning and Investment Manager

Recommended for Approval: _____ Date _____
District Project Development Engineer

Approved: _____ Date _____
District Administrator

ORIGINAL SIGNATURES ON TITLE SHEET OF ROAD PLANS
Date: April 28, 2023 © 2023, Commonwealth of Virginia Sheet 1 of 42

300-46_01.dgn

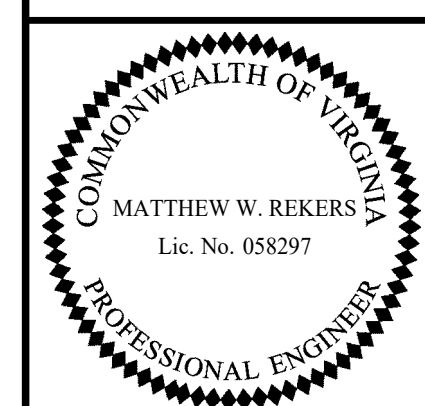

TRANSYSTEMS RICHMOND, VA STRUCTURAL ENGINEER	
PLANS BY:	Consultant
COORDINATED:	Len Gishner
SUPERVISED:	Alex R. Stone
DESIGNED:	Sagar Neelam
DRAWN:	Venkata A. Uppala
CHECKED:	Matthew W. Rekers

No.	Description	Date
REVISIONS		
For Table of Revisions, see Sheet 2.		

Scale: 1"=10'-0"

STATE	FEDERAL AID		STATE	SHEET
ROUTE	PROJECT		ROUTE	PROJECT
VA.			311	0311-080-913, B618
				3

Notes:

The substructure layout is for the purpose of locating fill slopes and footings for abutments. For details of neatwork, see Abutment sheets.

Material in the abutment select backfill zone shall be Select Material Type I, minimum CBR 30, and shall be compacted in accordance with Sections 303 and 305 of the VDOT Road and Bridge Specifications. 21A or 21B may be substituted for Select Material Type I, minimum CBR 30, at no additional cost to the Department.

In cut situations, material with strength characteristics greater than the select backfill may be left in place.

The final depth of the embankment side slopes shall be regular embankment material placed and finished as required.

For boring logs, see sheets 28 and 29.

For Retaining Wall Layout, Spread Footing Data Table for retaining walls, Section Through Retaining Walls - Cut Section, and additional boring locations, see sheet 30.

For metal stair concrete pilaster details, see sheets 9, 36 and 41.

For metal stair concrete footing details, see sheets 36 and 41.

⊙ - Denotes boring location.

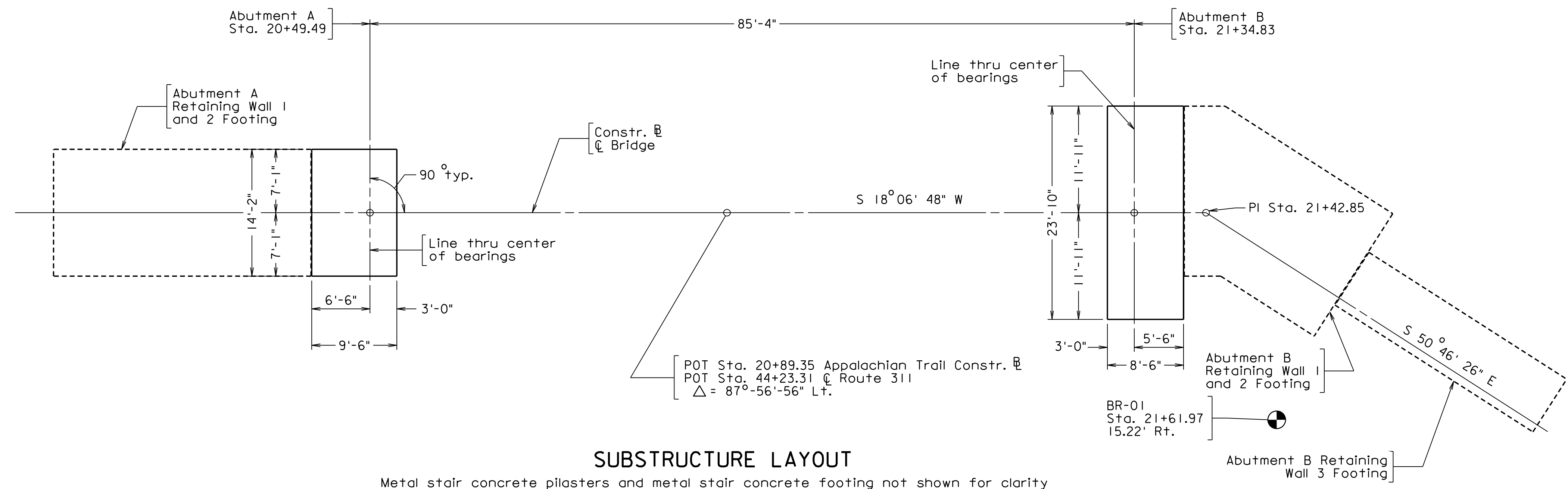

SUBSTRUCTURE LAYOUT

Metal stair concrete pilasters and metal stair concrete footing not shown for clarity

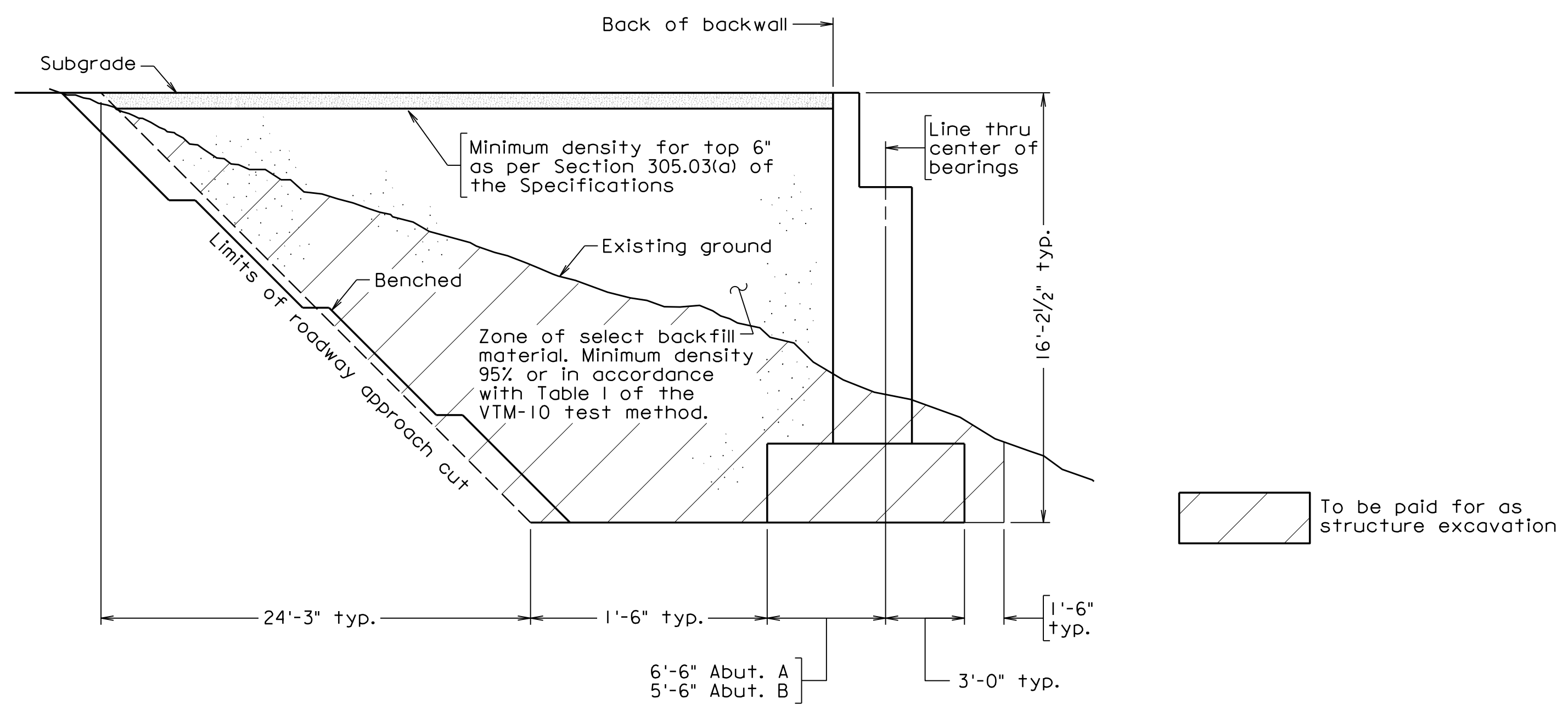

SECTION THROUGH ABUTMENT - CUT SECTION

Abutment drainage not shown
Not to scale

Substructure / Retaining Wall Unit	Anticipated Bearing Material	SERVICE LIMIT STATE		STRENGTH LIMIT STATE	
		Tolerable Settlement (inches)	Maximum Applied Bearing Pressure (tsf)	Maximum Factored Bearing Pressure (tsf)	Required Nominal Bearing Resistance (tsf)
Abutment A Footing	Rock	N/A	3.0	3.9	8.7
Abutment B Footing	Rock	N/A	2.1	2.7	6.0

• The larger of these two values, as well as the Anticipated Bearing Material, shall be verified by the Inspector or Engineer-of-Record prior to placing the footing concrete.

300-46-03.dgn

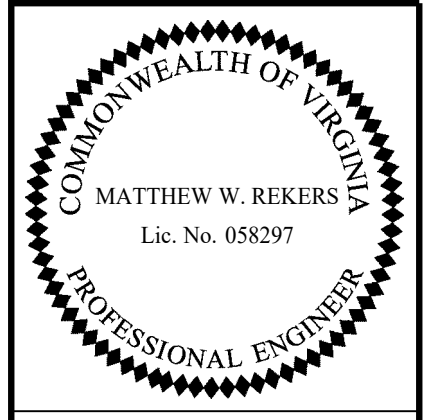

TRANSYSTEMS
RICHMOND, VA
STRUCTURAL ENGINEER

Scale: 1/8" = 1'-0" unless noted otherwise © 2023, Commonwealth of Virginia

COMMONWEALTH OF VIRGINIA DEPARTMENT OF TRANSPORTATION					
STRUCTURE AND BRIDGE DIVISION					
SUBSTRUCTURE LAYOUT					
No.	Description	Date	Designed: S.N.....	Date	Plan No.
			Drawn: V.A.U.....	Apr. 2023	300-46
			Checked: M.W.R.....		3 of 42
Revisions					

STATE	FEDERAL AID	STATE	SHEET
ROUTE	PROJECT	ROUTE	PROJECT
VA.		311	0311-080-913, B618
			4

Notes:

1" Preformed joint filler and 6" \emptyset solid wall schedule 40 PVC pipe costs to be included in bid item for Concrete Class A3.

Bottom of footing elevation shall not be lowered by more than one (1) foot.

For Footing Plan, see sheet 5.

For weephole spacing within wing walls, see sheet 6.

For Coping Detail, and Architectural Treatment see sheet 7.

For Wing Haunch Details, Abutment A Anchor Bolt Layout, Wash Detail and Weephole Reinforcement Detail, see sheet 13.

For Abutment A Reinforcement Schedule, see sheet 25.

See VDOT Road and Bridge Standard S-2 (Pages 601.03 and 601.04) for 2:1 Concrete Stairs.

See VDOT Road and Bridge Standard HR-1 (Page 601.05) for HR-1 Type I and HR-1 Type II Handrails. Handrails shall be painted brown.

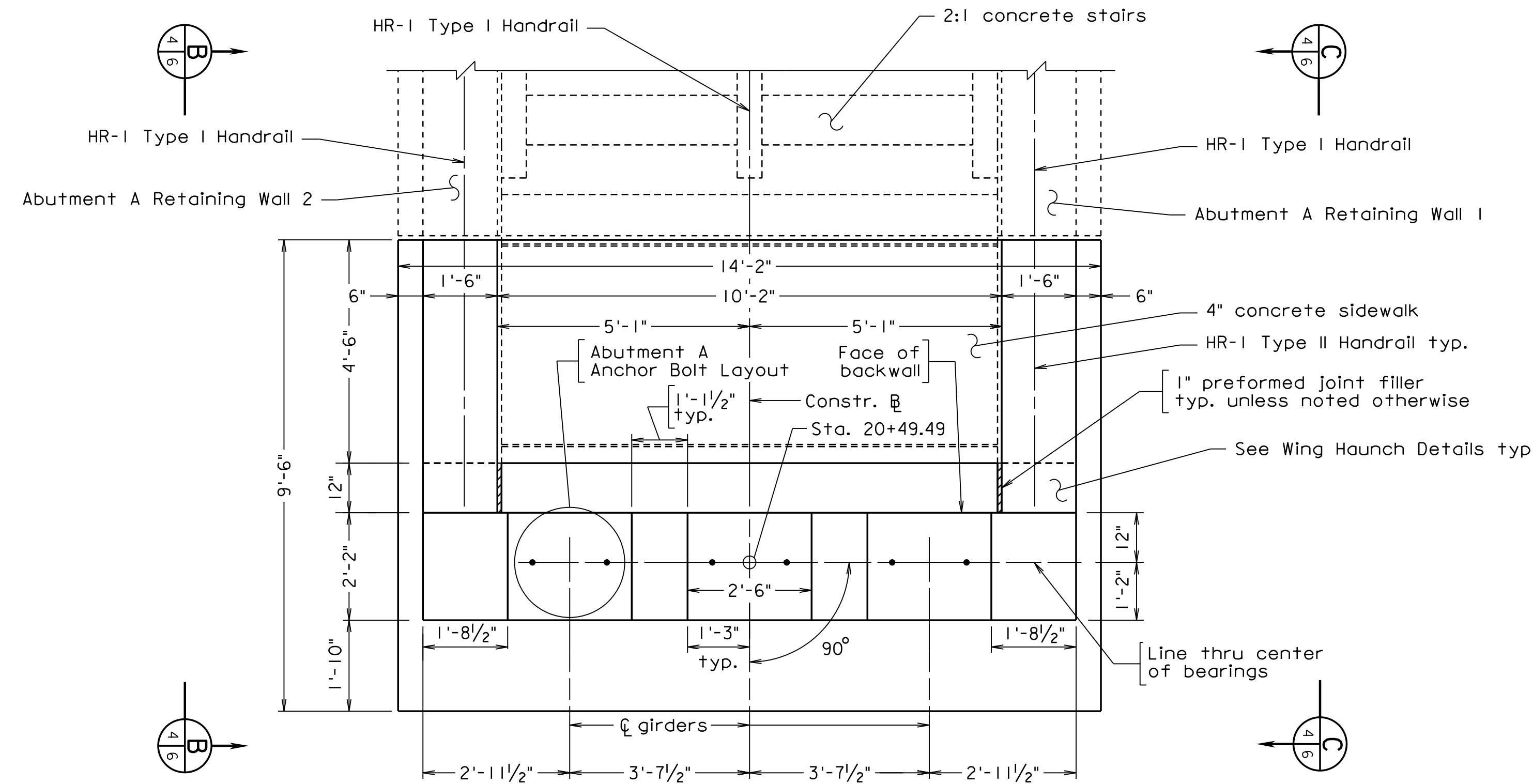

PLAN

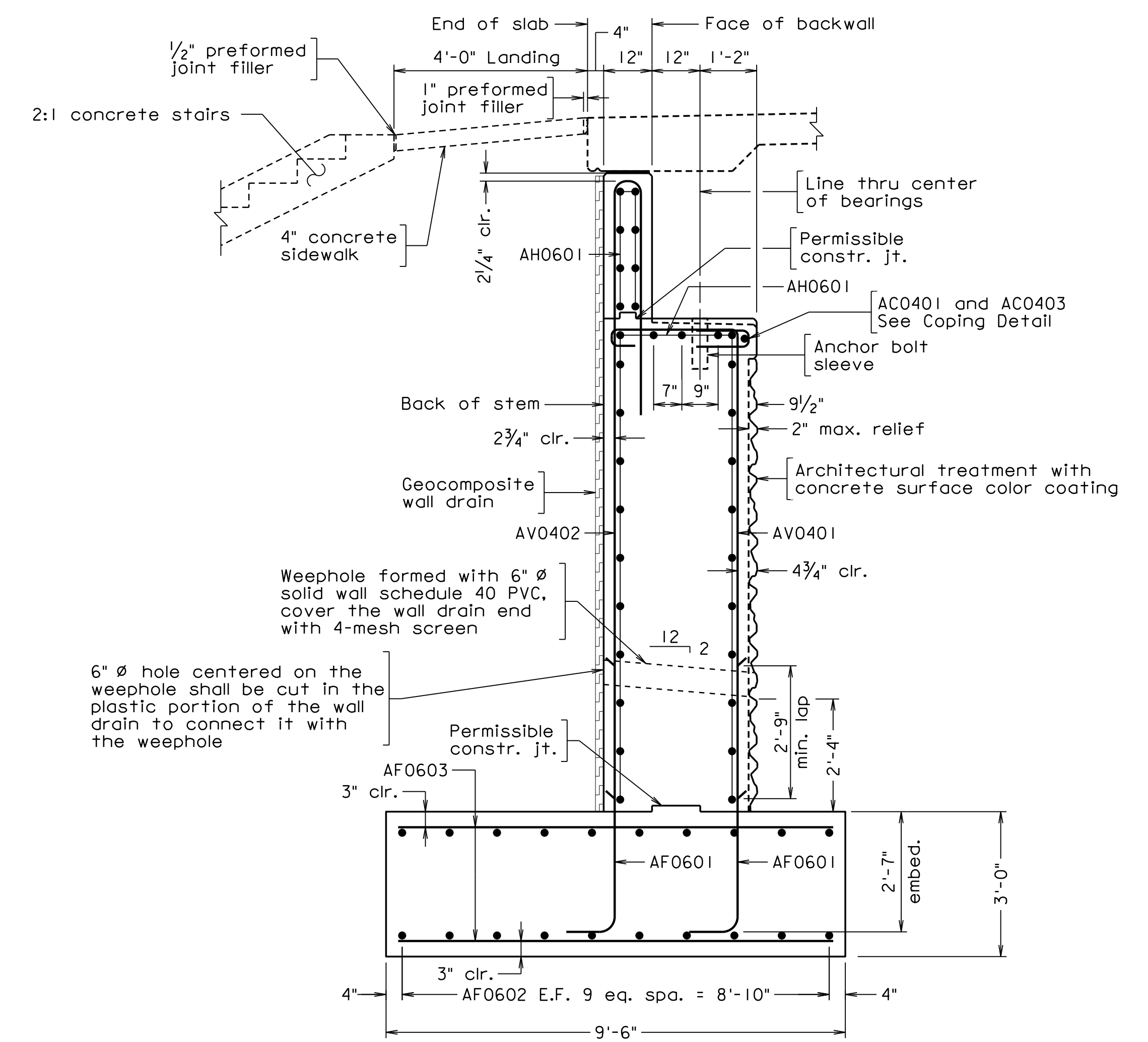

SECTION A-A

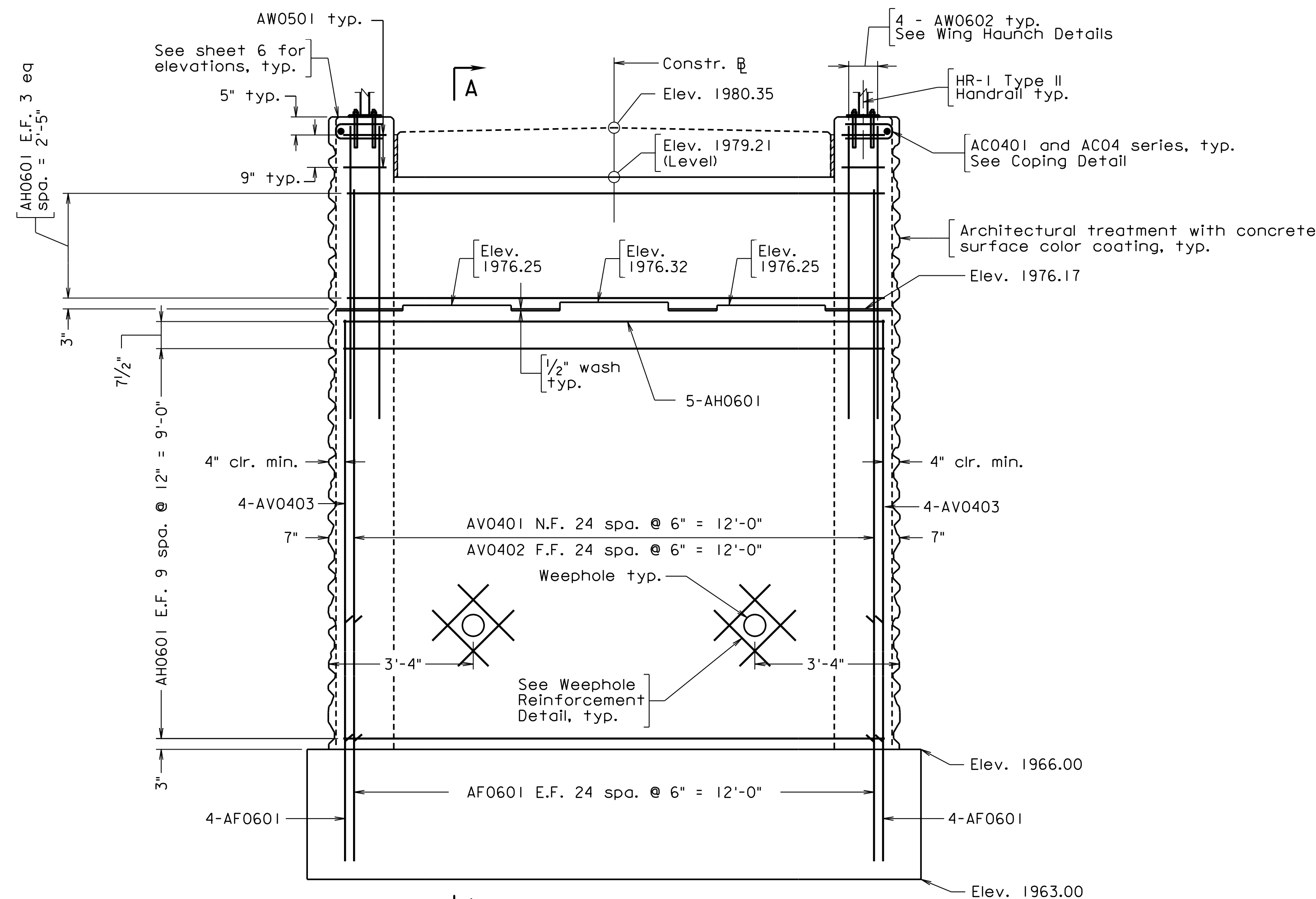

ELEVATION

300-46_04.dgn

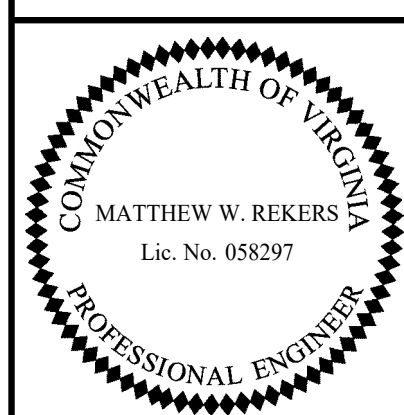

TRANSYSTEMS
RICHMOND, VA
STRUCTURAL ENGINEER

Scale: 1/2" = 1'-0"

©2023, Commonwealth of Virginia

COMMONWEALTH OF VIRGINIA DEPARTMENT OF TRANSPORTATION					
STRUCTURE AND BRIDGE DIVISION					
ABUTMENT A PLAN AND ELEVATION					
No.	Description	Date	Designed: S.N.....	Date	Plan No.
			Drawn: M.W.R.....	Apr. 2023	300-46
			Checked: M.W.R.....		4 of 42
Revisions					

STATE	FEDERAL AID		STATE		SHEET
ROUTE	PROJECT		ROUTE	PROJECT	NO.
VA.	—		311	0311-080-913, B618	5

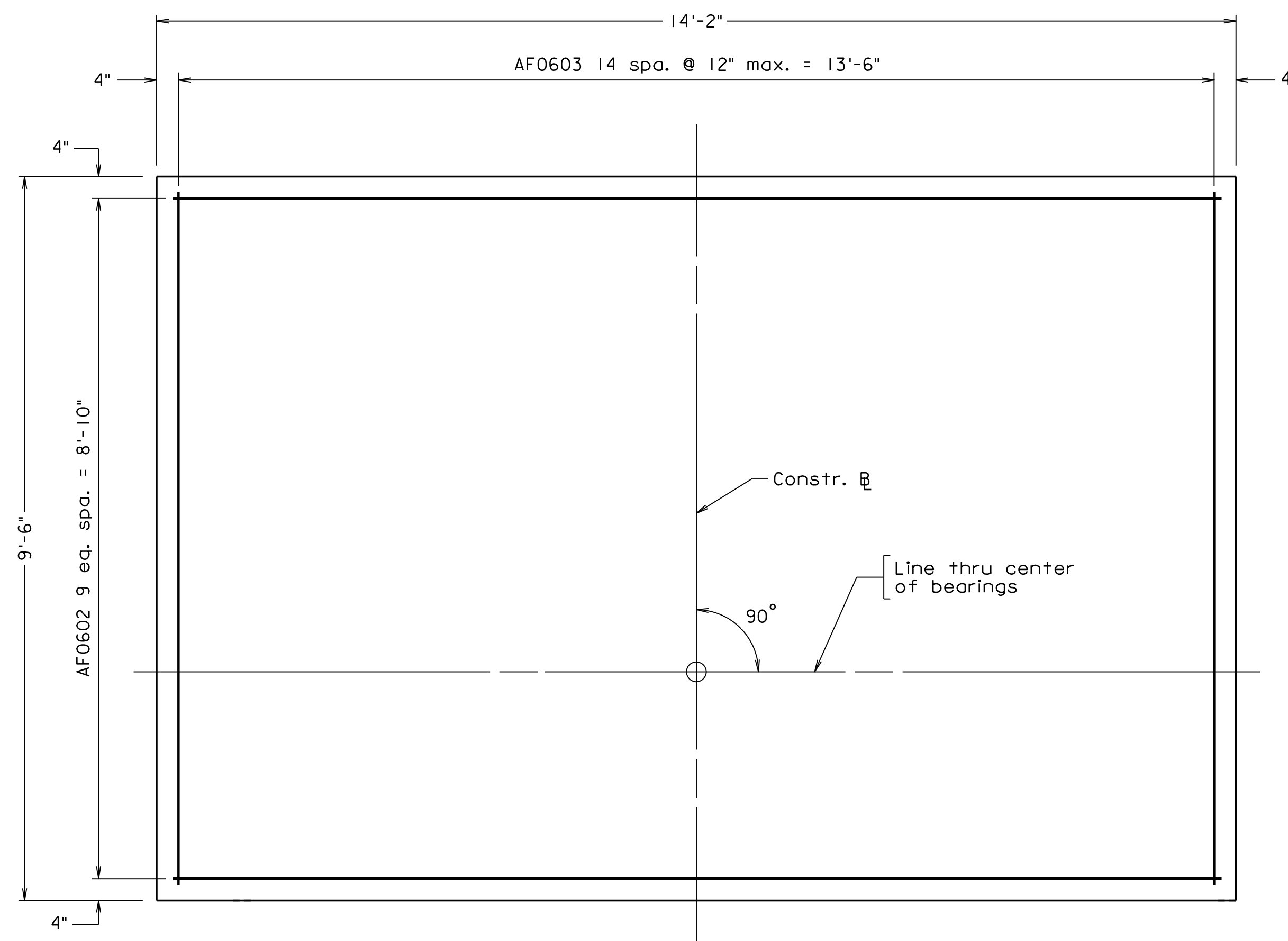
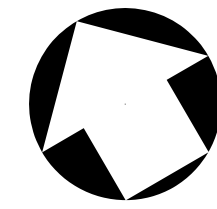

FOOTING PLAN

Top reinforcing shown, bottom similar

300-46-05.dgn

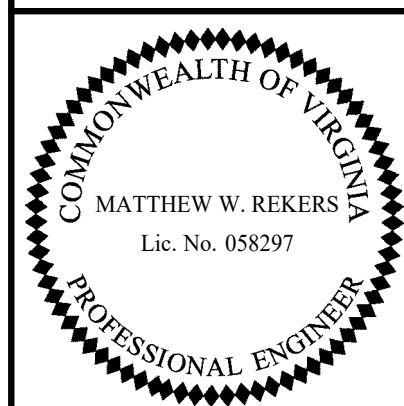

TRANSYSTEMS
RICHMOND, VA
STRUCTURAL ENGINEER

Scale: 3/4" = 1'-0"

©2023, Commonwealth of Virginia

COMMONWEALTH OF VIRGINIA DEPARTMENT OF TRANSPORTATION					
STRUCTURE AND BRIDGE DIVISION					
ABUTMENT A FOOTING PLAN					
No.	Description	Date	Designed: S.N..... Drawn:V.A.U.. Checked: M.W.R....	Date Apr. 2023	Plan No. 300-46
Revisions					Sheet No. 5 of 42

STATE	FEDERAL AID		STATE	SHEET
ROUTE	PROJECT		ROUTE	PROJECT
VA.			311	0311-080-913, B618
				7

Notes:

Form liner shall be arranged to produce a continuous drystack pattern without obvious repetition of the pattern.

Form liner pattern shall be inspected and approved by the Department.

Contractor shall submit shop drawings with pattern layout for approval by the Department.

A color coating of Dark Gray No. 595-36492 shall be applied to the full lengths of front face of stem, front face of backwall, and front faces and top sides of wing walls.

For Abutment A Reinforcement Schedule, see sheet 25.

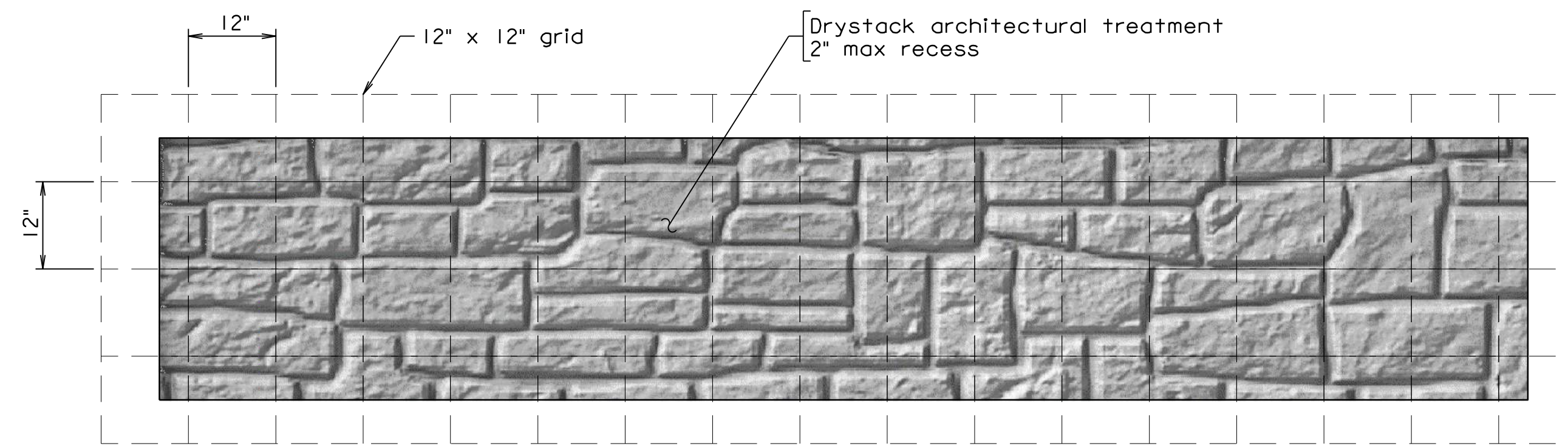

DRystack TEXTURE DETAIL
Substructure - Front Face

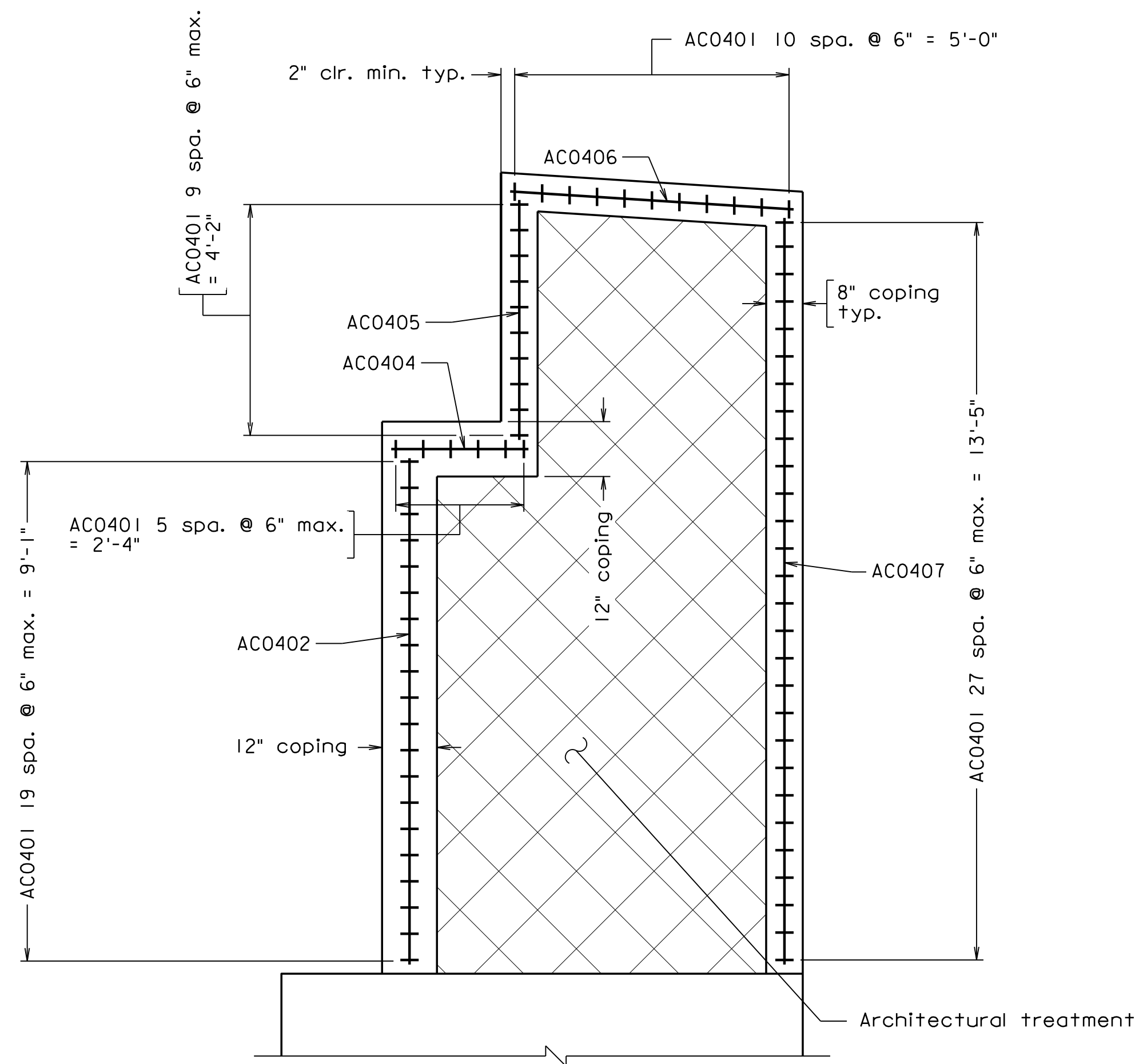

ABUTMENT A WING WALLS COPING AND ARCHITECTURAL TREATMENT

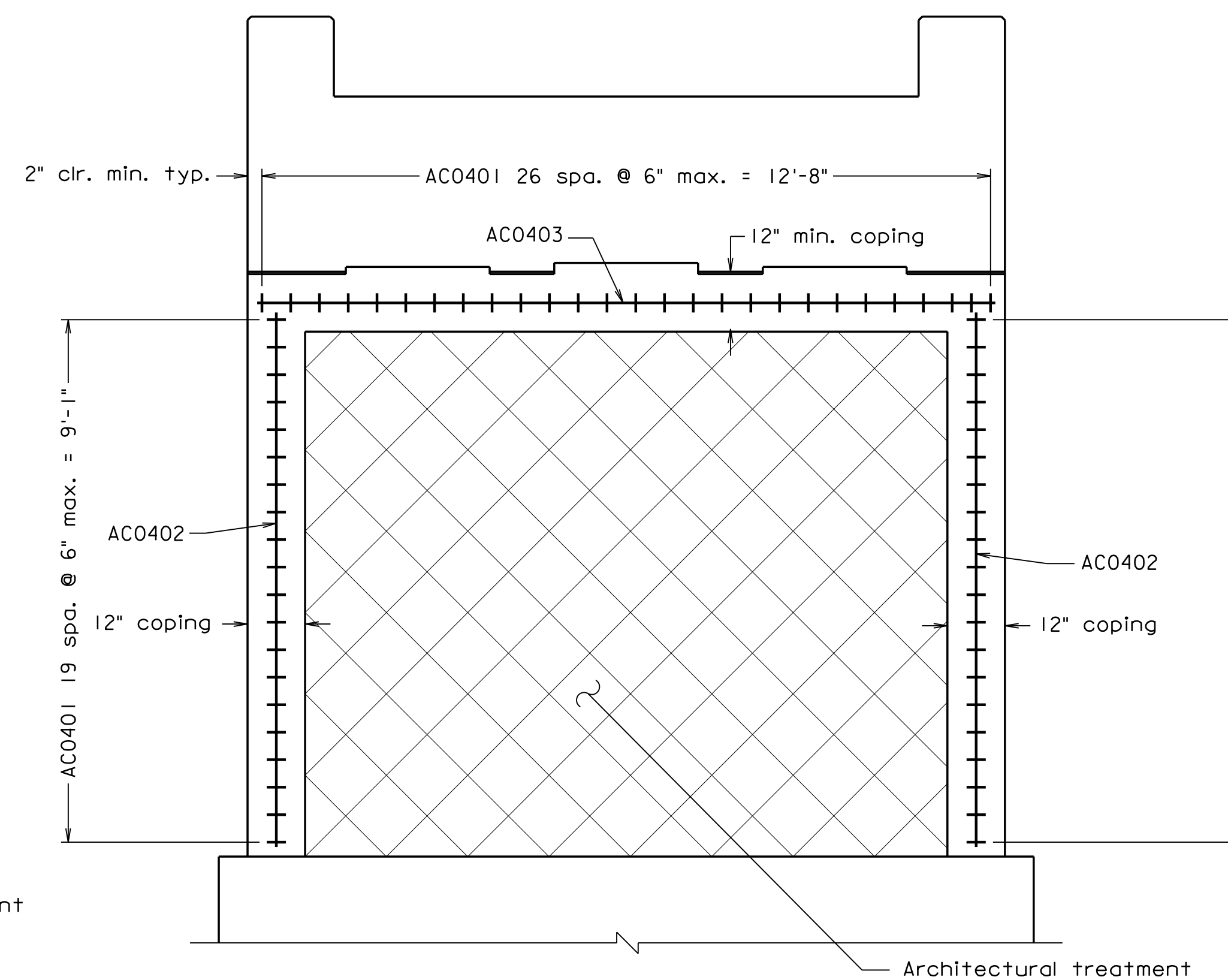

ABUTMENT A COPING AND ARCHITECTURAL TREATMENT

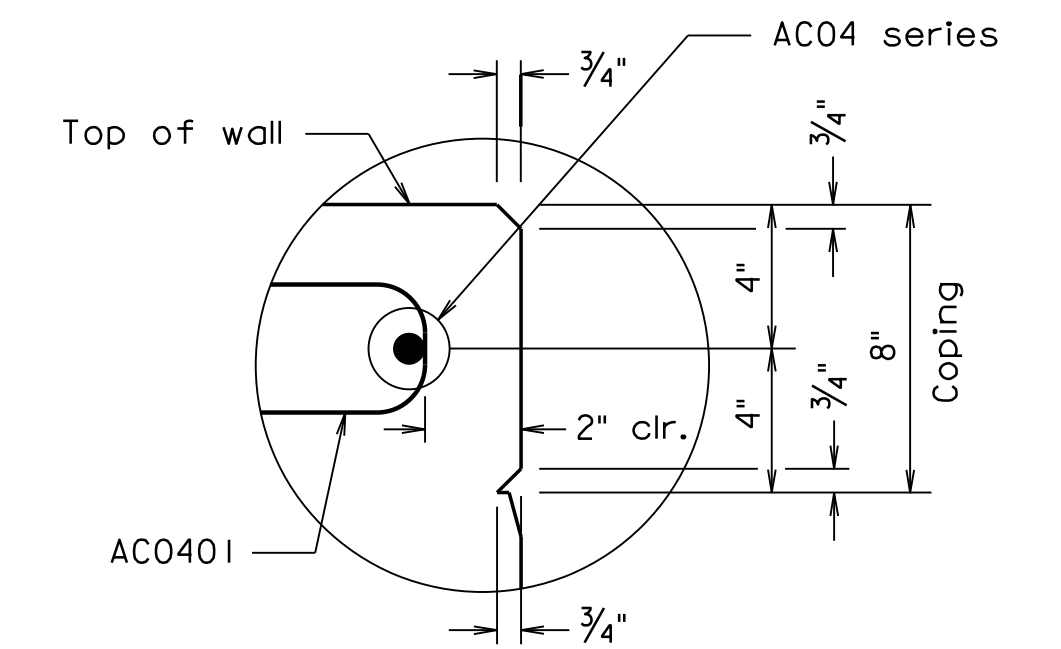

8" COPING DETAIL
Not to scale

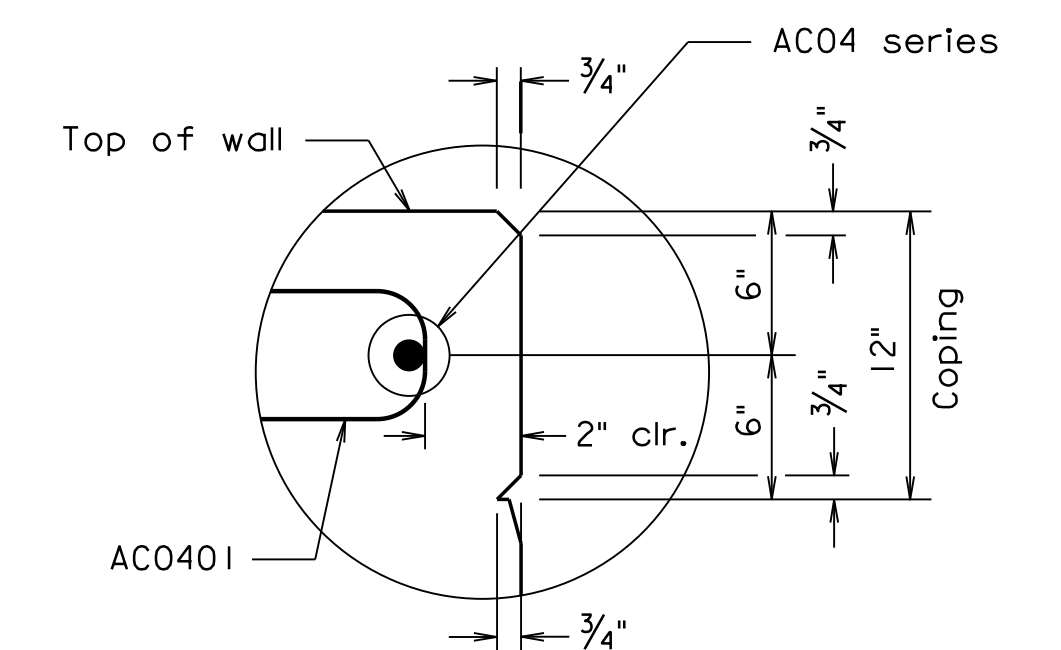

12" COPING DETAIL
Not to scale

300-46-07.dgn

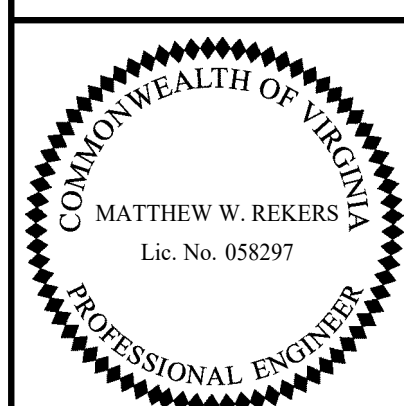

TRANSYSTEMS
RICHMOND, VA
STRUCTURAL ENGINEER

Scale: 1/2" = 1'-0" 2023, Commonwealth of Virginia

COMMONWEALTH OF VIRGINIA DEPARTMENT OF TRANSPORTATION STRUCTURE AND BRIDGE DIVISION					
ABUTMENT A ARCHITECTURAL TREATMENT					
No.	Description	Date	Designed: S.N..... Drawn: V.A.U..... Checked: M.W.R.....	Date Apr. 2023	Plan No. 300-46
Revisions					Sheet No. 7 of 42

STATE	FEDERAL AID	STATE	SHEET
ROUTE	PROJECT	ROUTE	PROJECT
VA.		311	0311-080-913, B618
			8

Notes:

- 1" Preformed joint filler and 6"Ø solid wall schedule 40 PVC pipe costs to be included in bid item for Concrete Class A3.
- Bottom of footing elevation shall not be lowered by more than one (1) foot.
- For Footing Plan and metal stair pilaster locations, see sheet 9.
- For weephole spacing within wing walls, see sheets 10 and 11.
- For Coping Details and Architectural Treatment, see sheet 12.
- For Wing Haunch Details, Wing Haunch Details 2, Abutment B Anchor Bolt Layout, Wash Detail and Weephole Reinforcement Detail, see sheet 13.
- For Abutment B Reinforcement Schedule, see sheet 26.
- For metal stair pilaster reinforcement details, see sheet 41.
- See VDOT Road and Bridge Standard HR-1 (Page 601.05) for HR-1 Type II Handrail details. Handrails shall be painted brown.

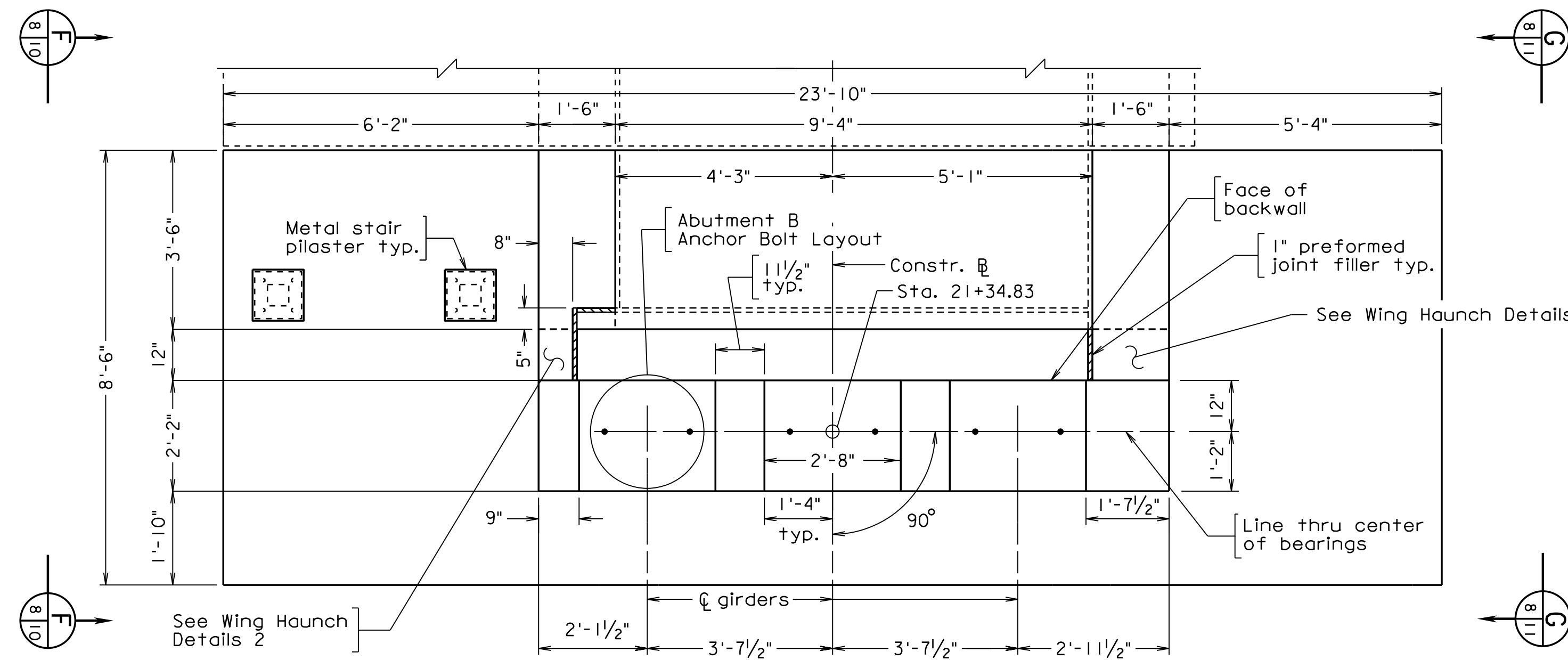

PLAN

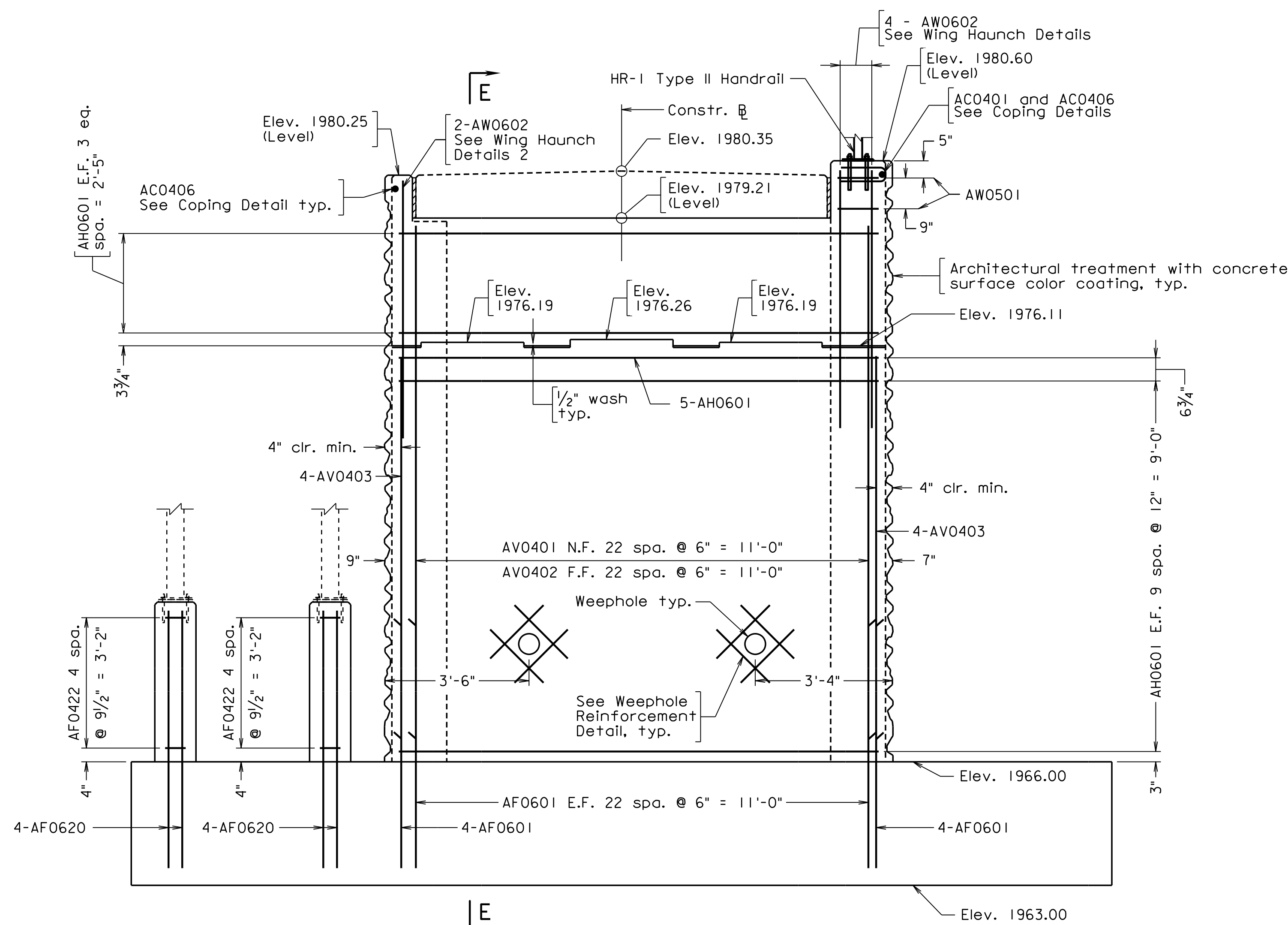

ELEVATION

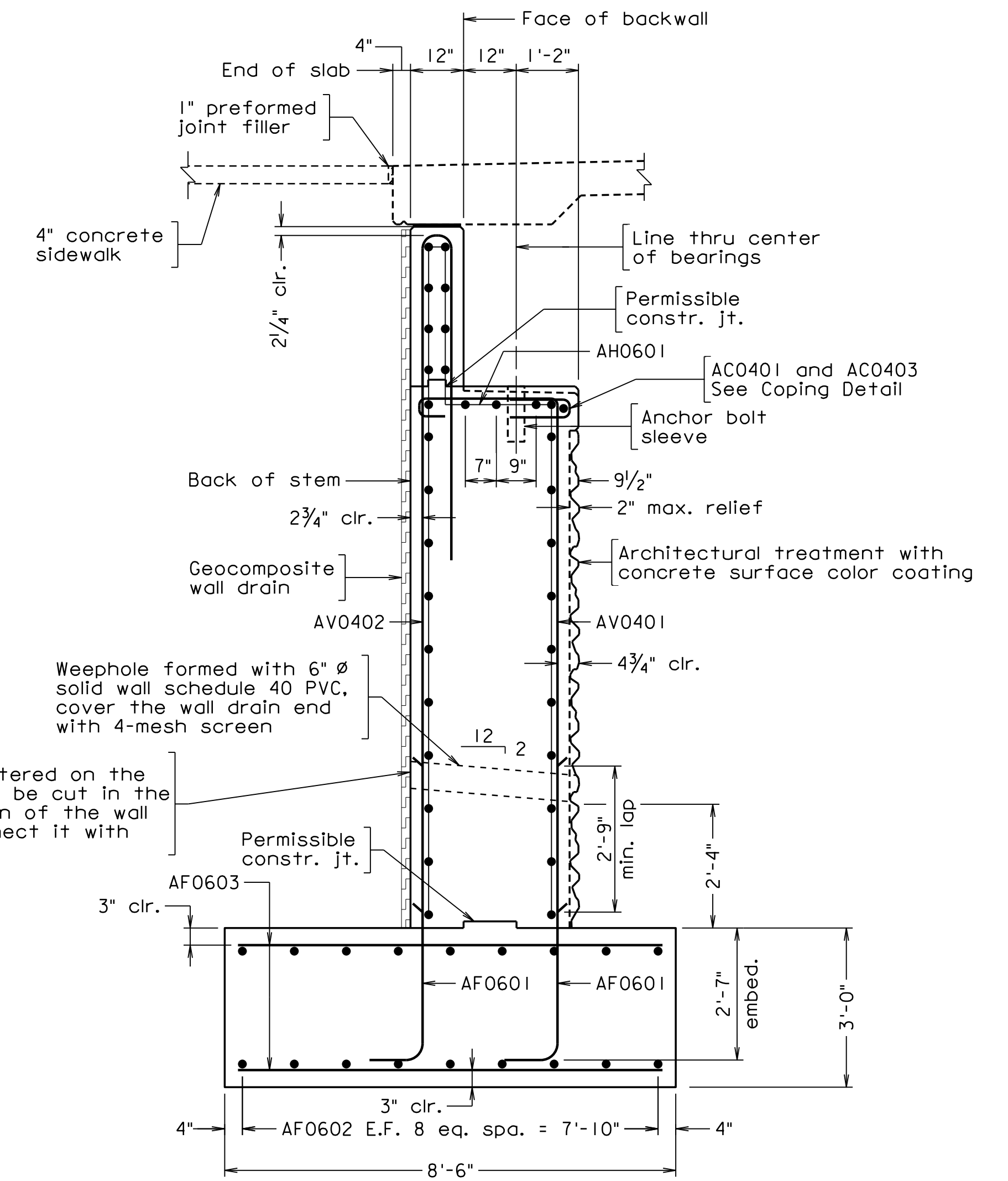

SECTION E-E

300-46-08.dgn

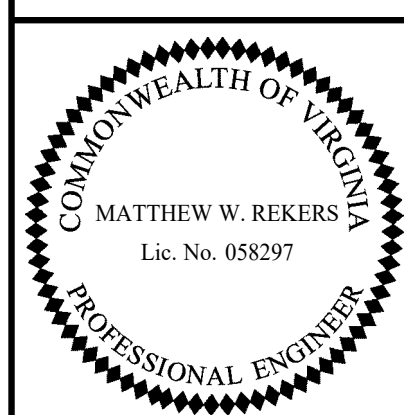

TRANSYSTEMS
RICHMOND, VA
STRUCTURAL ENGINEER

Scale: 1/2" = 1'-0"

©2023, Commonwealth of Virginia

COMMONWEALTH OF VIRGINIA DEPARTMENT OF TRANSPORTATION					
STRUCTURE AND BRIDGE DIVISION					
ABUTMENT B PLAN AND ELEVATION					
No.	Description	Date	Designed: S.N.....	Date	Plan No.
	Revisions		Drawn:V.A.U.....	Apr. 2023	300-46
			Checked: M.W.R.....		8 of 42

STATE	FEDERAL AID		STATE		SHEET
ROUTE	PROJECT		ROUTE	PROJECT	NO.
VA.	—		311	0311-080-913, B618	9

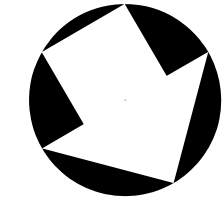

Notes:
For metal stair concrete pilaster details, see sheet 41.

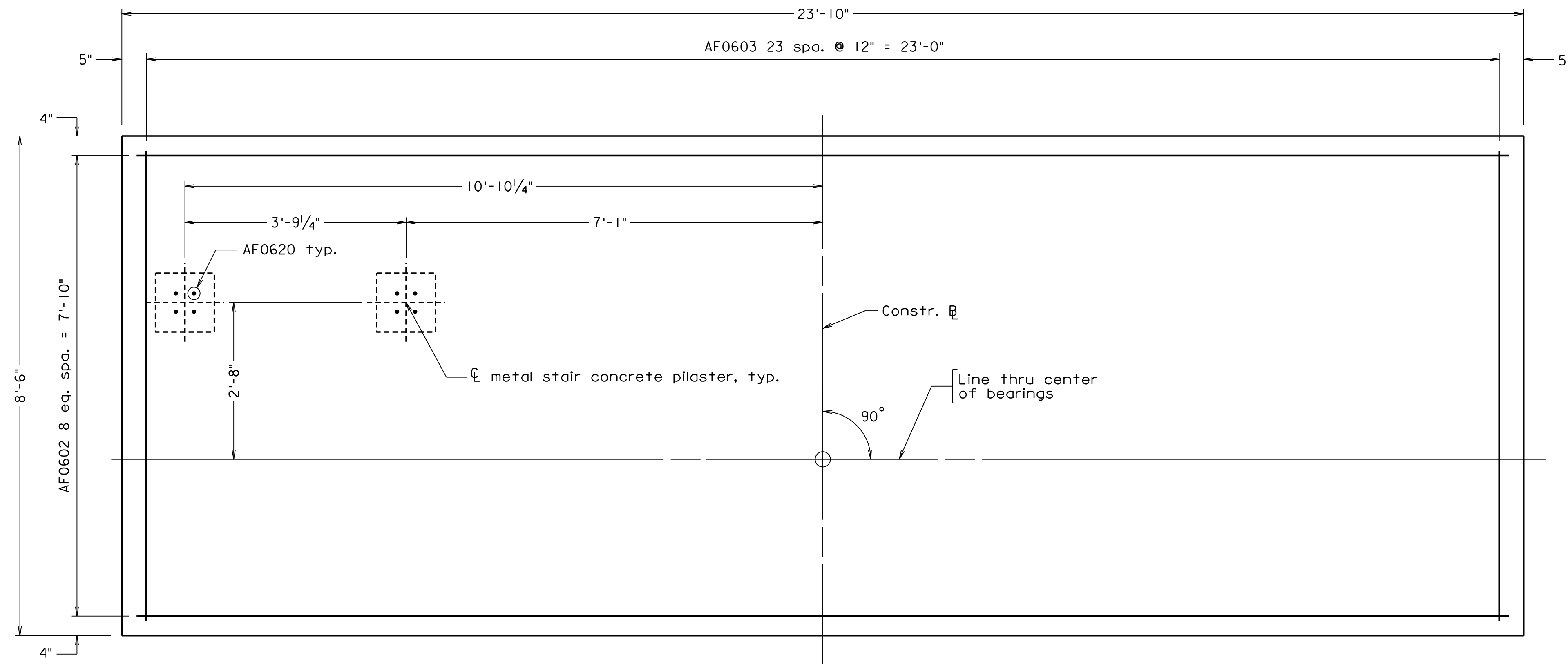

FOOTING PLAN

Top reinforcing shown, bottom similar

300-46_05.dgn

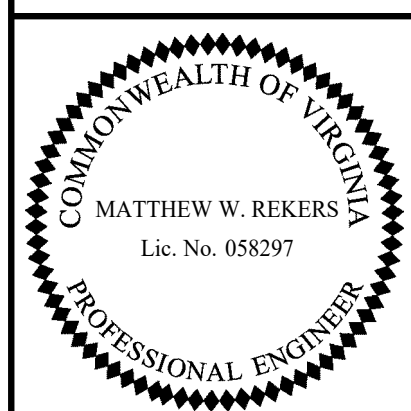

TRANSYSTEMS
RICHMOND, VA
STRUCTURAL ENGINEER

COMMONWEALTH OF VIRGINIA DEPARTMENT OF TRANSPORTATION					
STRUCTURE AND BRIDGE DIVISION					
ABUTMENT B FOOTING PLAN					
No.	Description	Date	Designed: S.N.....	Date	Plan No.
			Drawn: V.A.U.....	Apr. 2023	300-46
			Checked: M.W.R.....		9 of 42
Revisions					

Scale: 3/4" = 1'-0"

© 2023, Commonwealth of Virginia

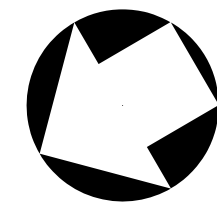

STATE	FEDERAL AID		STATE	SHEET
ROUTE	PROJECT		ROUTE	PROJECT
VA.			311	0311-080-913, B618
				10

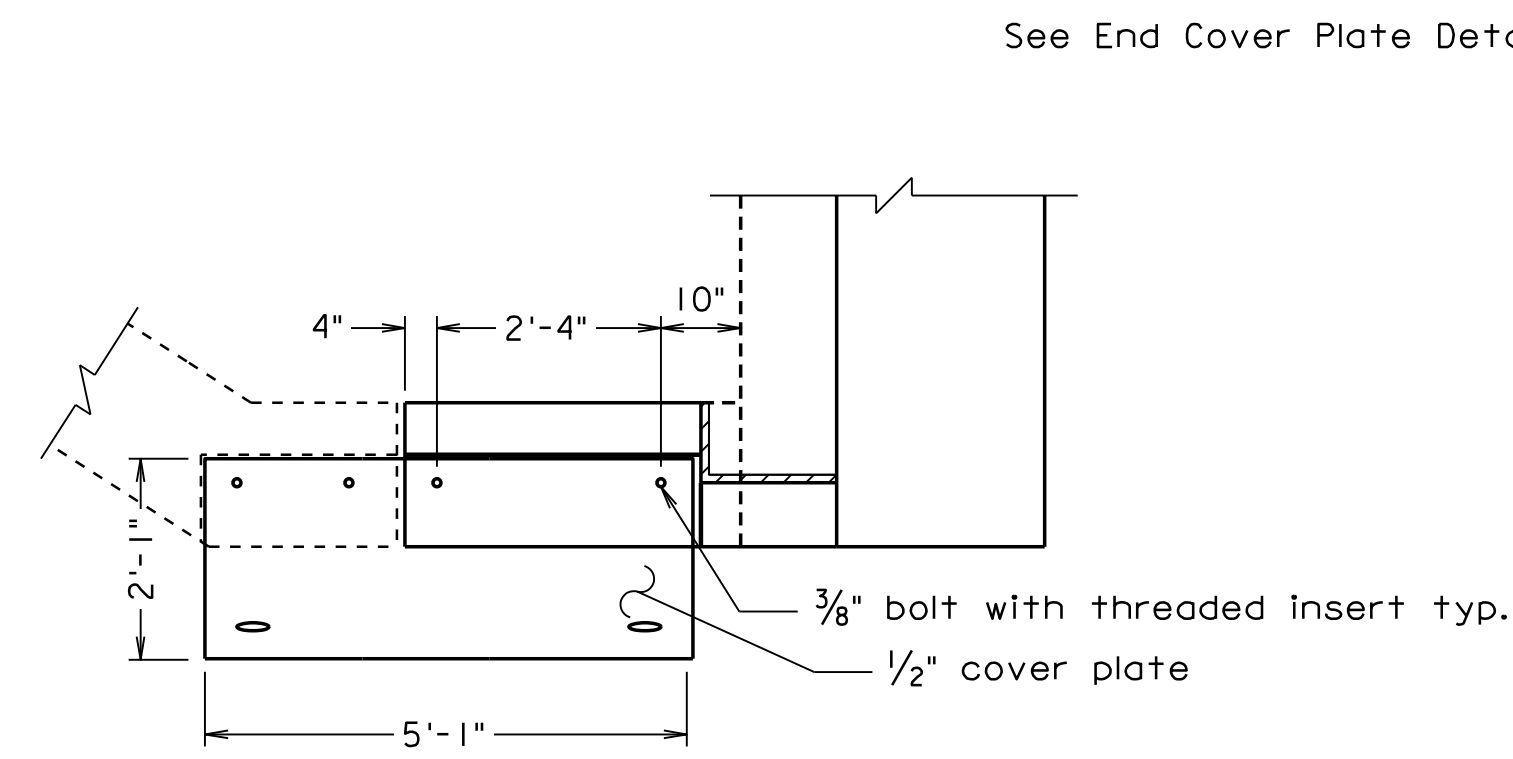

PLAN

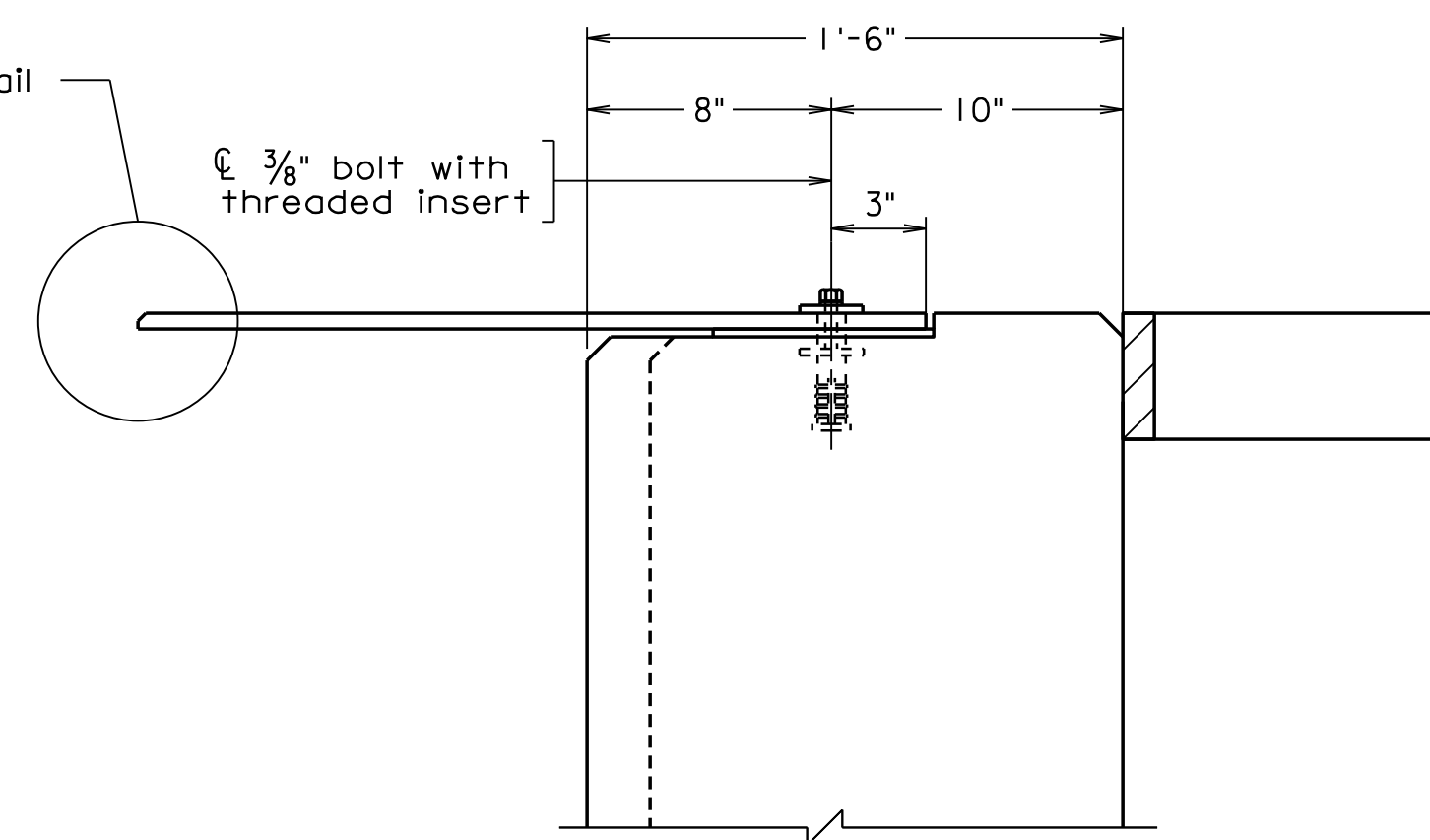

THREADED INSERT DETAIL

Scale: 2" = 1'-0"

Note:

Place reinforcing to avoid weephole. 6" \emptyset hole centered on the weephole shall be cut in the plastic portion of the wall drain to connect it with the weephole.

Bottom of footing elevation shall not be lowered by more than one (1) foot.

For Footing Plan, see sheet 9.

For Architectural Treatment and Coping Details, see sheet 12.

For Weephole Reinforcement Detail and Corner Reinforcement Detail, see sheet 13.

For Abutment B Reinforcement Schedule, see sheet 26.

For End Cover Plate Detail and additional cover plate details and information, see sheet 34 and Special Provision for Metal Stairs.

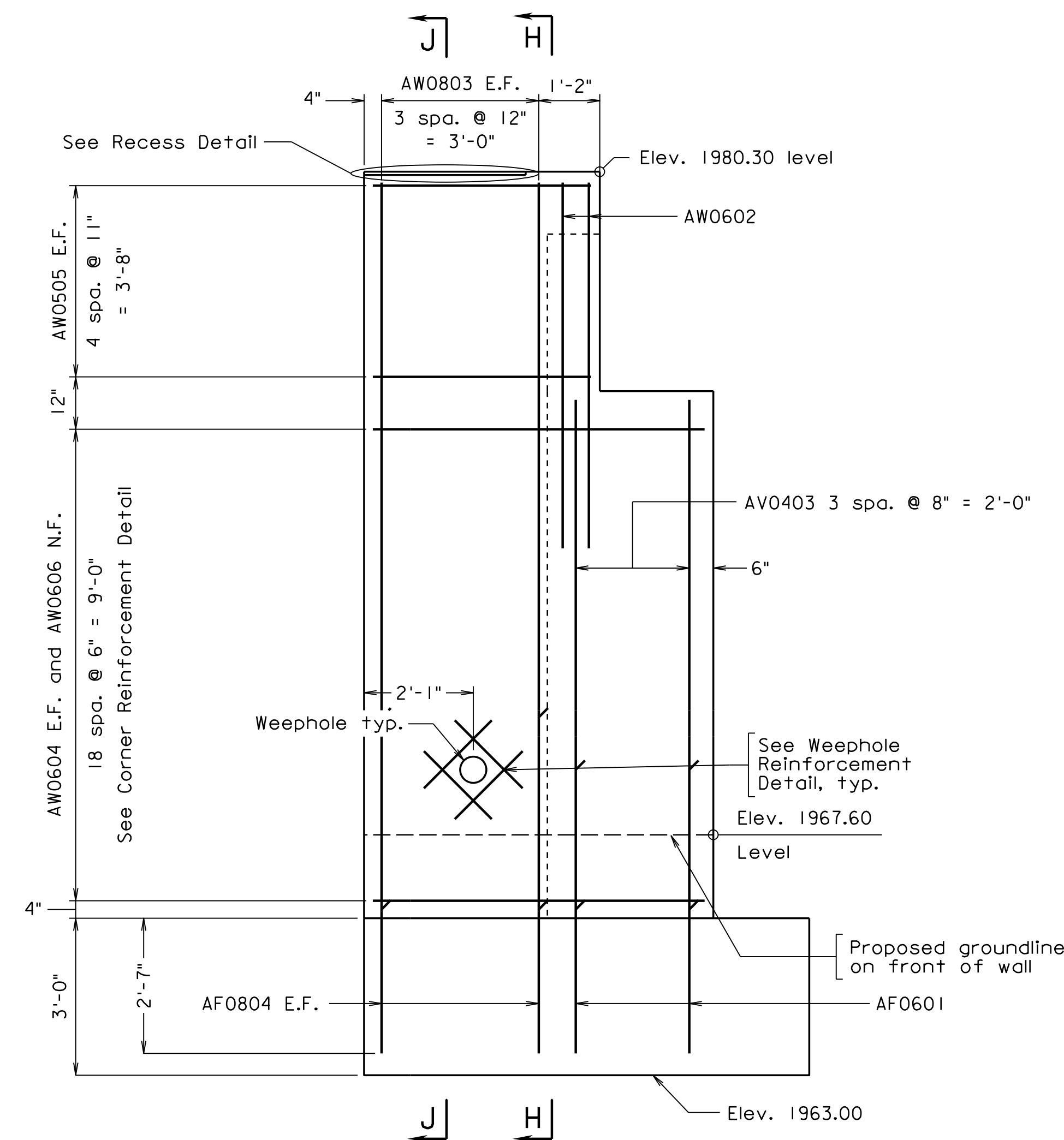

VIEW $\frac{F}{8 \ 10}$

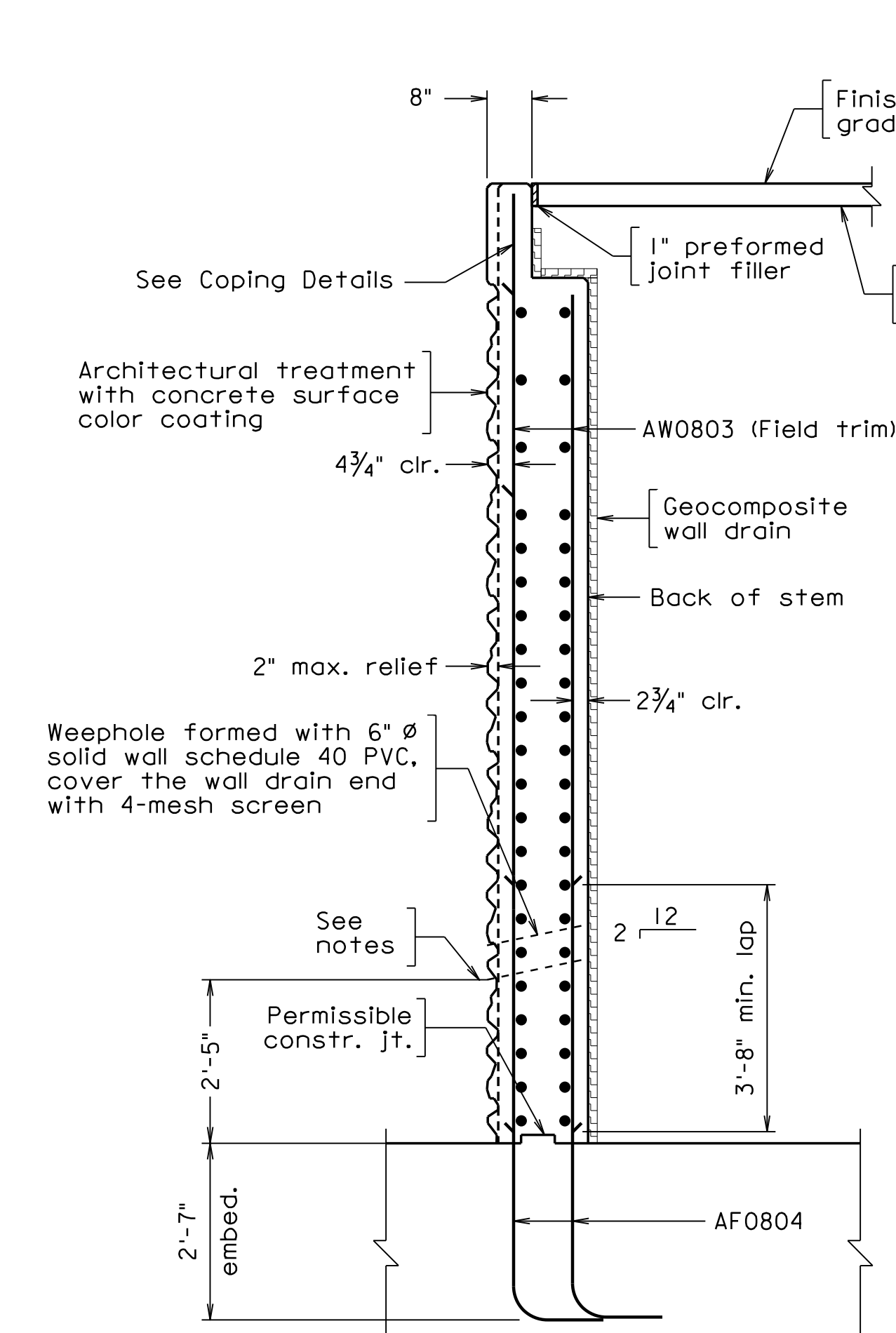

SECTION H-H

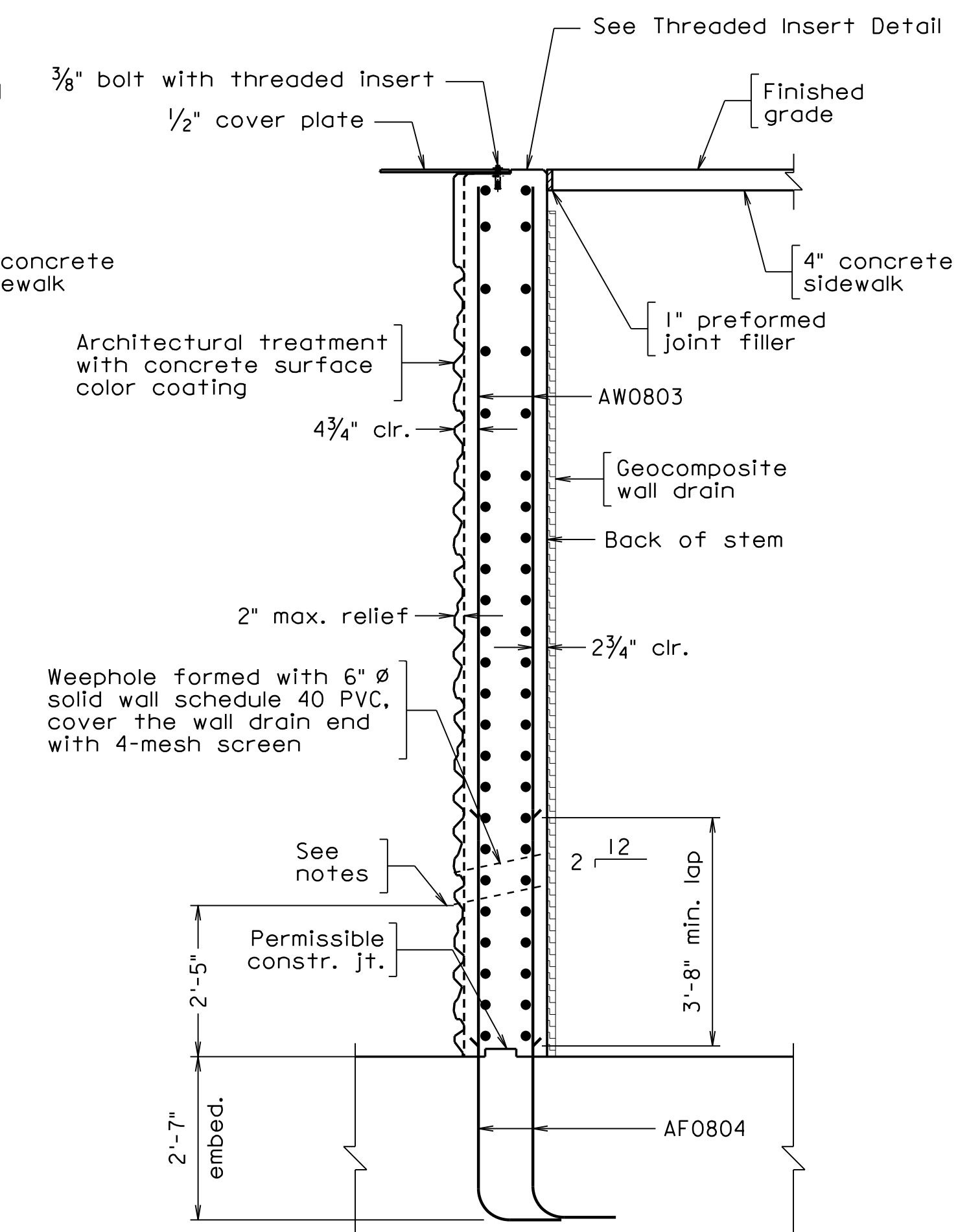

SECTION J-J

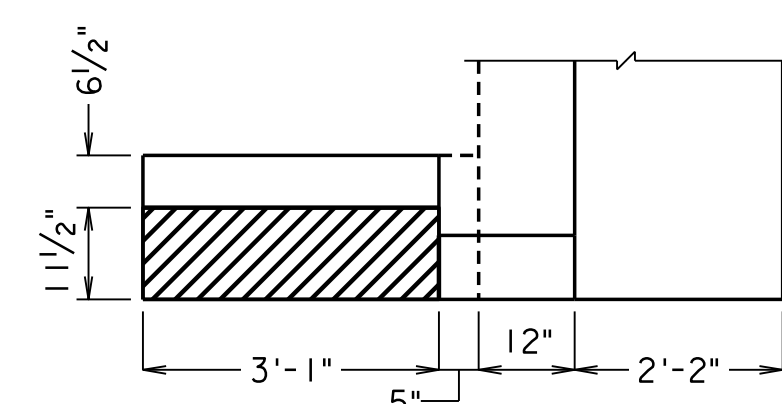

RECESS DETAIL

Scale: 1" = 1'-0"

300-46_10.dgn

COMMONWEALTH OF VIRGINIA
 MATTHEW W. REKERS
 Lic. No. 058297
 PROFESSIONAL ENGINEER

TRANSYSTEMS
 RICHMOND, VA
 STRUCTURAL ENGINEER

Scale: 1/2" = 1'-0", unless otherwise shown © 2023, Commonwealth of Virginia

COMMONWEALTH OF VIRGINIA DEPARTMENT OF TRANSPORTATION					
STRUCTURE AND BRIDGE DIVISION					
ABUTMENT B WING WALLS (1 OF 2)					
No.	Description	Date	Designed: I.B.W....	Date	Plan No.
			Drawn: I.B.W....	Apr. 2023	300-46
			Checked: M.W.B....		10 of 42
Revisions					

STATE	FEDERAL AID		STATE		SHEET
ROUTE	PROJECT		ROUTE	PROJECT	NO.
VA.			311	0311-080-913, B618	11

Note:

Place reinforcing to avoid weephole. 6" Ø hole centered on the weephole shall be cut in the plastic portion of the wall drain to connect it with the weephole.

Bottom of footing elevation shall not be lowered by more than one (1) foot.

For Footing Plan, see Sheet 9.

For Architectural Treatment and Coping Details, see sheet 12.

For Weephole Reinforcement Detail, Corner Reinforcement Detail, and Handrail Anchor Bolt Details, see sheet 13.

For Abutment B Reinforcement Schedule, see sheet 26.

See VDOT Road and Bridge Standard HR-1 (Page 601.05) for HR-1 Type II Handrail. Handrails shall be painted brown.

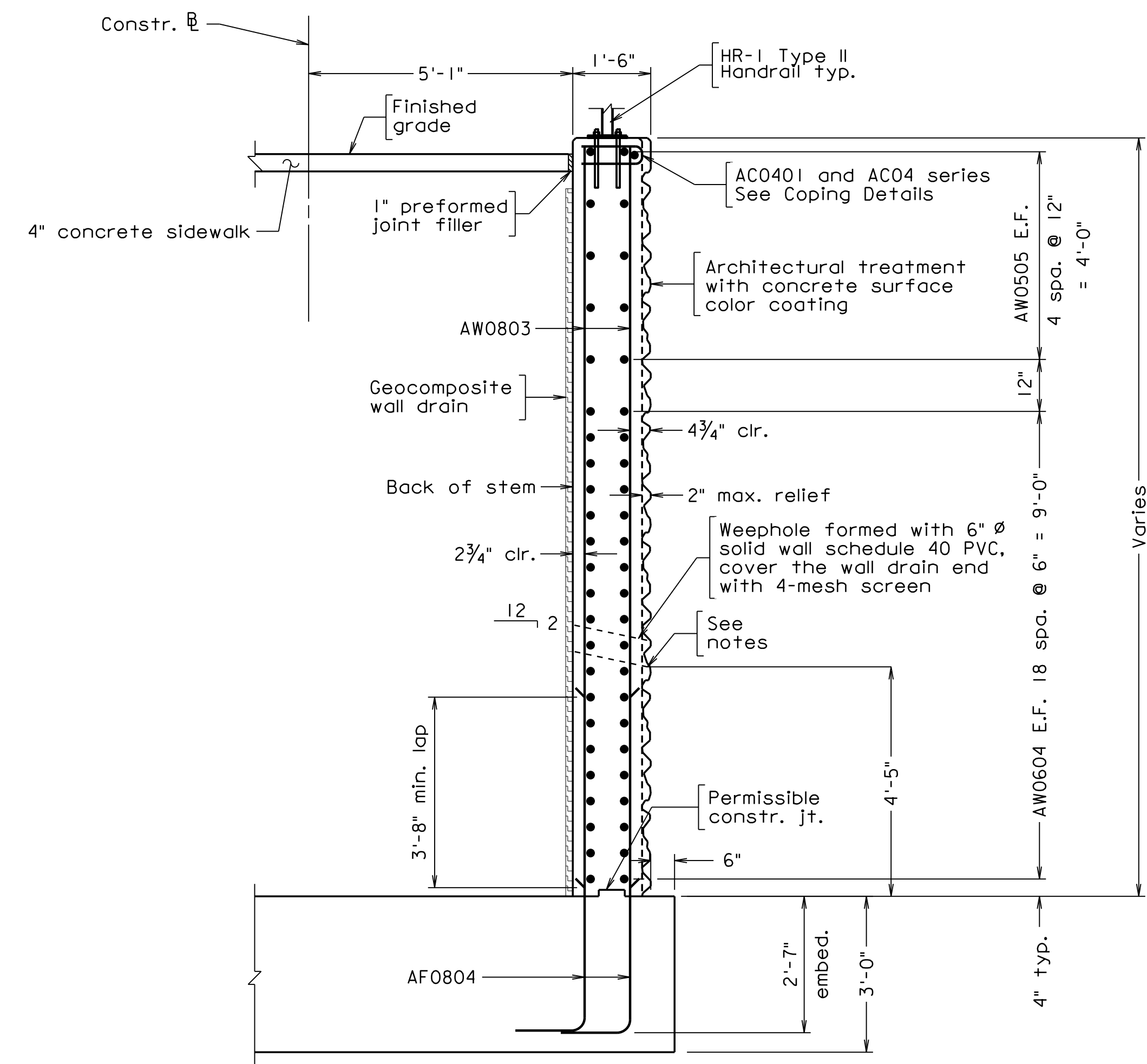
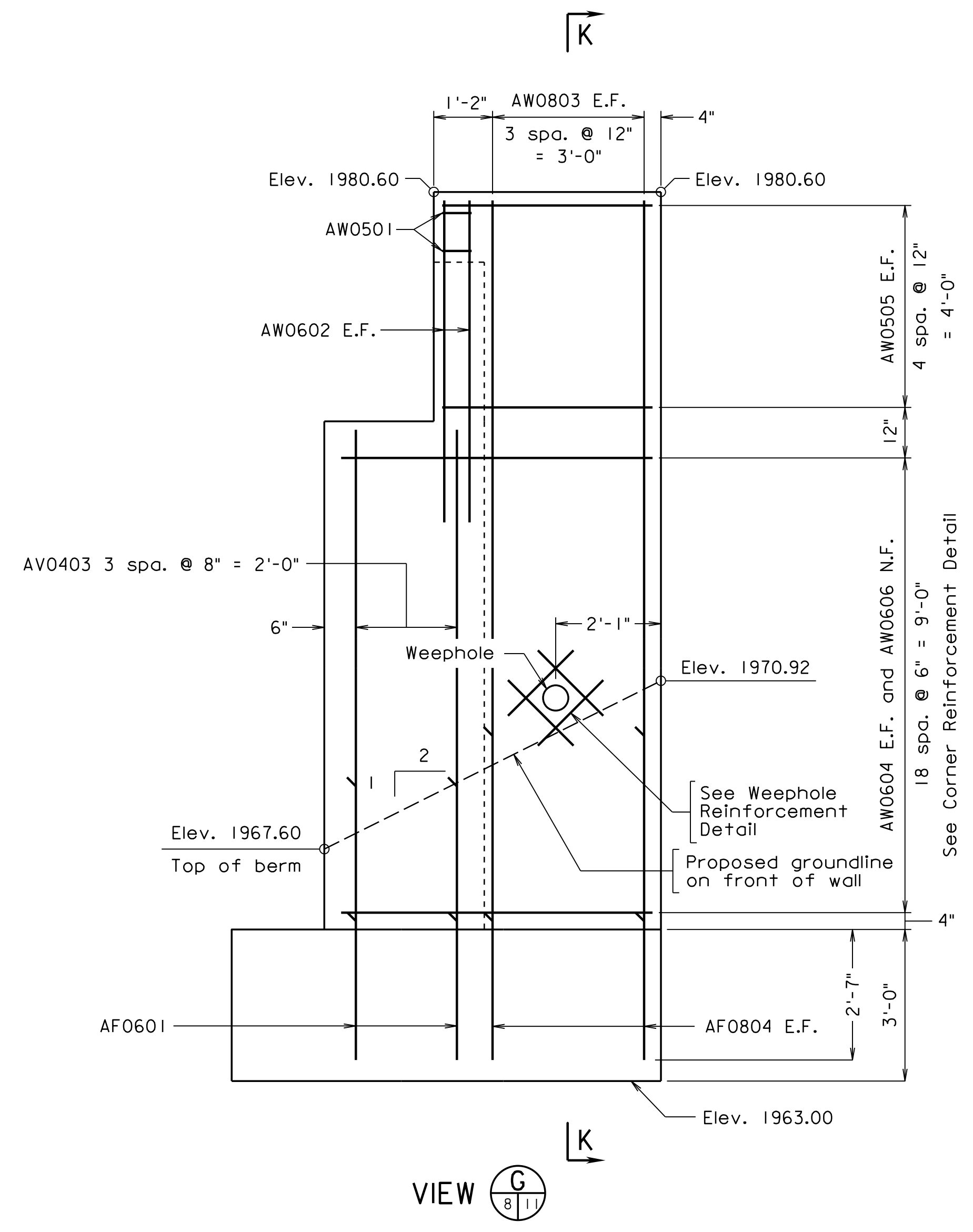

SECTION K-K

300-46_11.dgn

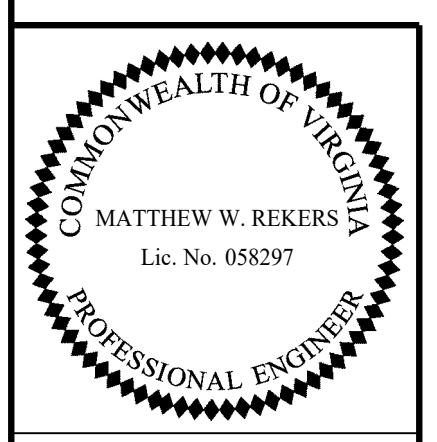

TRANSYSTEMS
RICHMOND, VA
STRUCTURAL ENGINEER

Scale: 1/2" = 1'-0", unless otherwise shown © 2023, Commonwealth of Virginia

COMMONWEALTH OF VIRGINIA DEPARTMENT OF TRANSPORTATION				
STRUCTURE AND BRIDGE DIVISION				
ABUTMENT B WING WALLS (2 OF 2)				
No.	Description	Date	Designed: I.B.W.... Drawn: I.B.W.... Checked: M.W.B....	Date Apr. 2023
Revisions			Plan No. 300-46	Sheet No. 11 of 42

STATE	FEDERAL AID		STATE	SHEET
ROUTE	PROJECT		ROUTE	PROJECT
VA.			311	0311-080-913, B618
				12

Notes:

Form liner shall be arranged to produce a continuous drystack pattern without obvious repetition of the pattern.

Form liner pattern shall be inspected and approved by the Department.

Contractor shall submit shop drawings with pattern layout for approval by the Department.

A color coating of Dark Gray No. 595-36492 shall be applied to the full lengths of front face of stem, front face of backwall, and front faces and top sides of wing walls.

For Drystack Texture Detail and Coping Details, see sheet 7.

For Abutment B Reinforcement Schedule, see sheet 26.

300-46_12.dgn

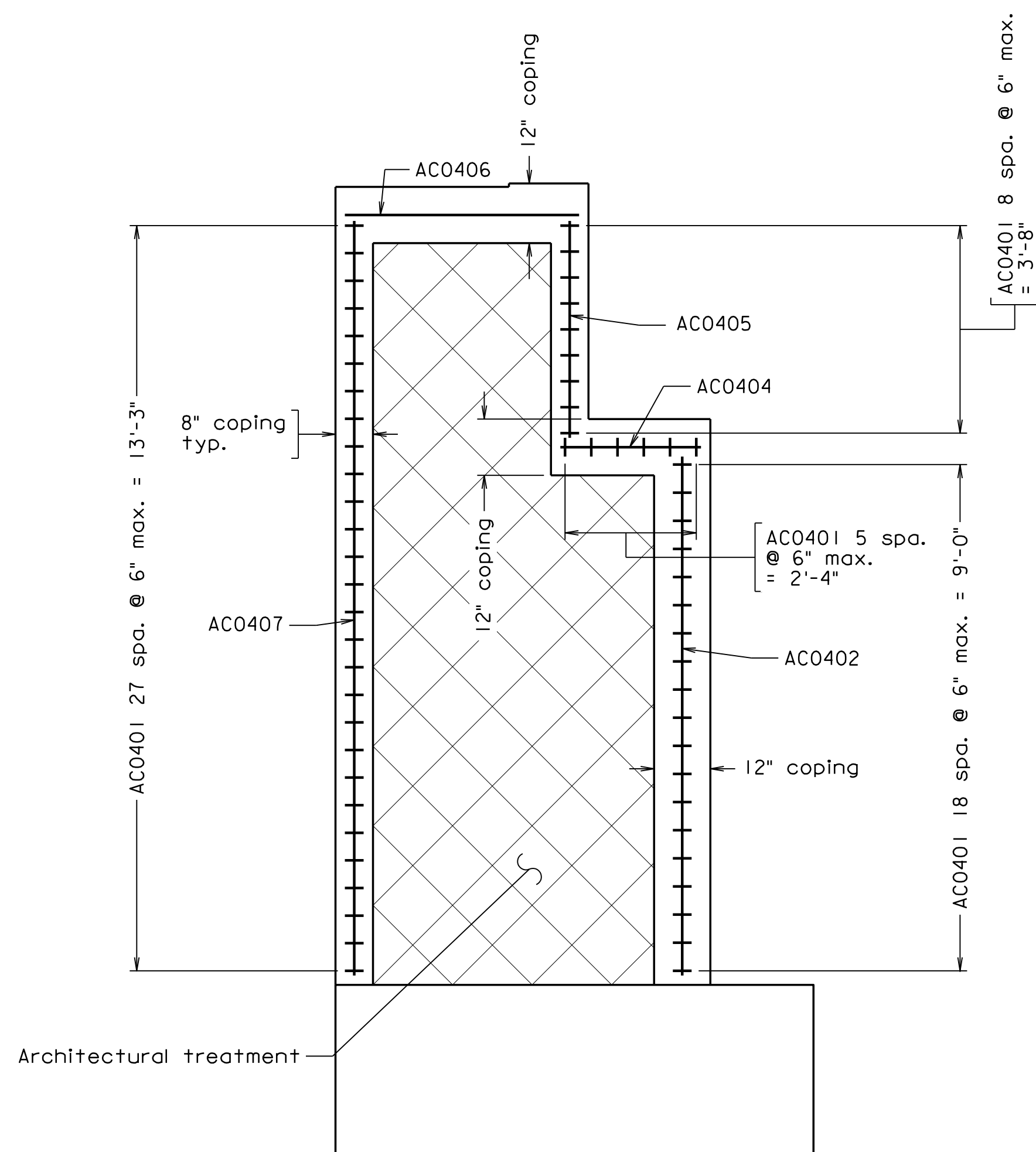

ABUTMENT B LEFT WING WALL
COPING AND ARCHITECTURAL TREATMENT

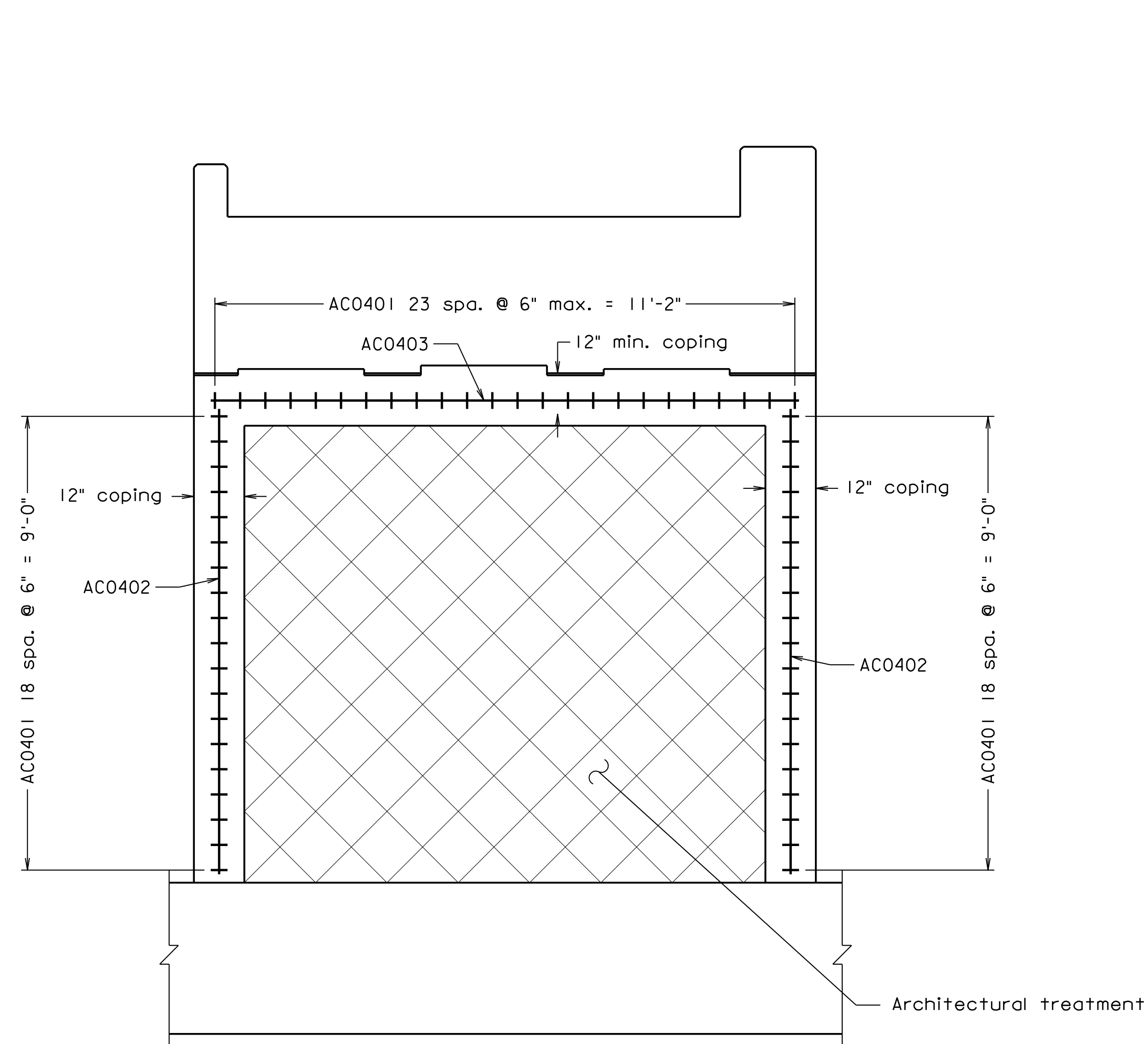

ABUTMENT B
COPING AND ARCHITECTURAL TREATMENT

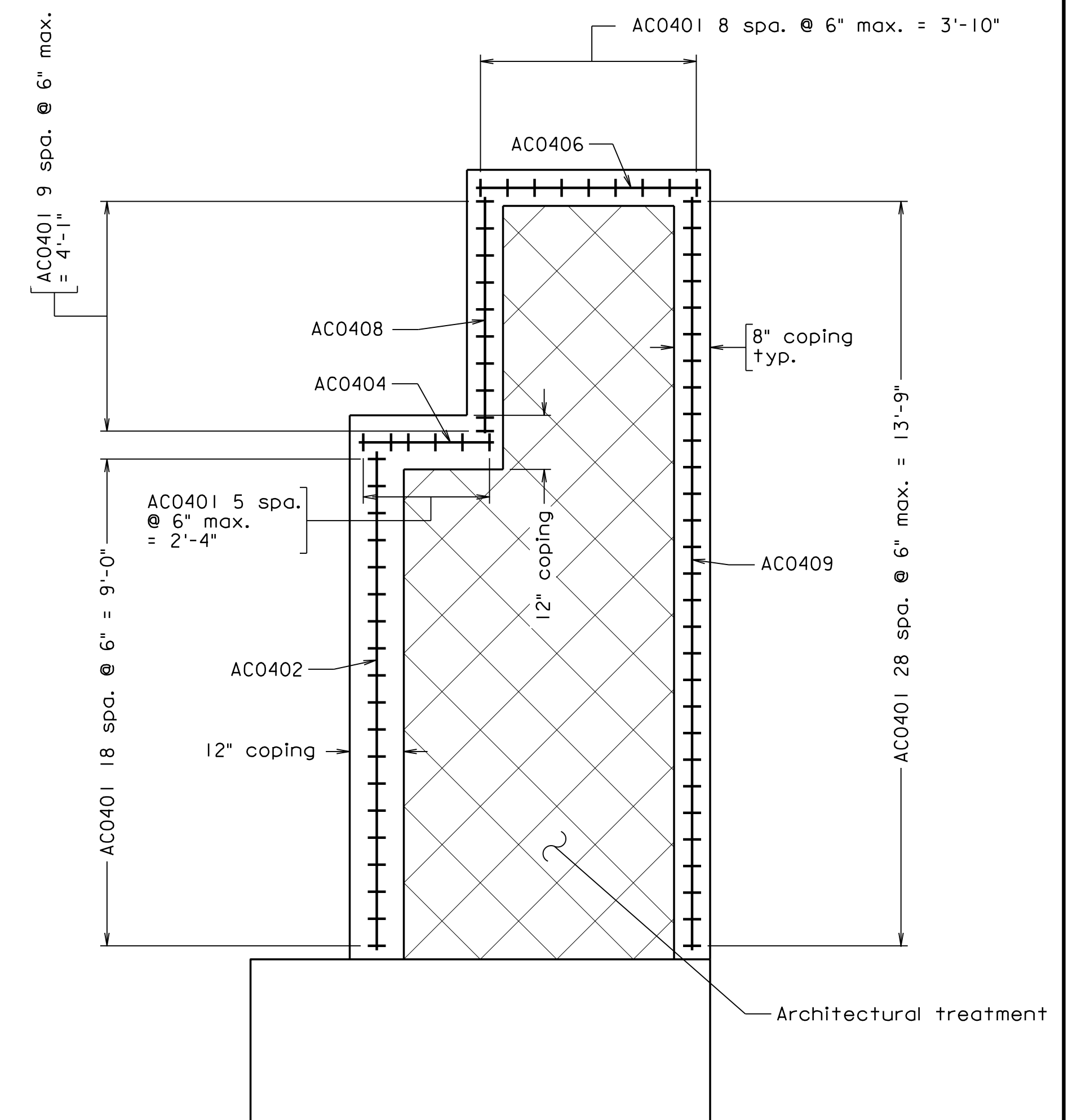

ABUTMENT B RIGHT WING WALL
COPING AND ARCHITECTURAL TREATMENT

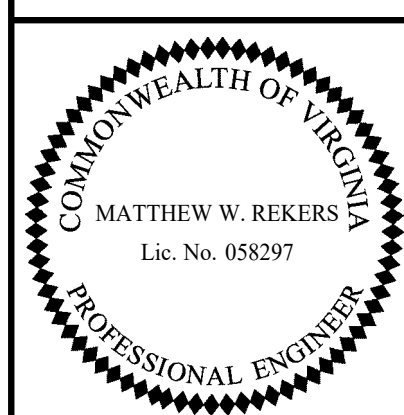

TRANSYSTEMS
RICHMOND, VA
STRUCTURAL ENGINEER

Scale: 1/2" = 1'-0"

© 2023, Commonwealth of Virginia

COMMONWEALTH OF VIRGINIA DEPARTMENT OF TRANSPORTATION					
STRUCTURE AND BRIDGE DIVISION					
ABUTMENT B ARCHITECTURAL TREATMENT					
No.	Description	Date	Designed: S.N.....	Date	Plan No.
			Drawn: V.A.U.....	Apr. 2023	300-46
			Checked: M.W.R.....		12 of 42
Revisions					

STATE	FEDERAL AID	STATE	SHEET
ROUTE	PROJECT	ROUTE	PROJECT
VA.		311	0311-080-913, B618
			13

Notes:

Cost of joint filler shall be included in the price for substructure concrete.

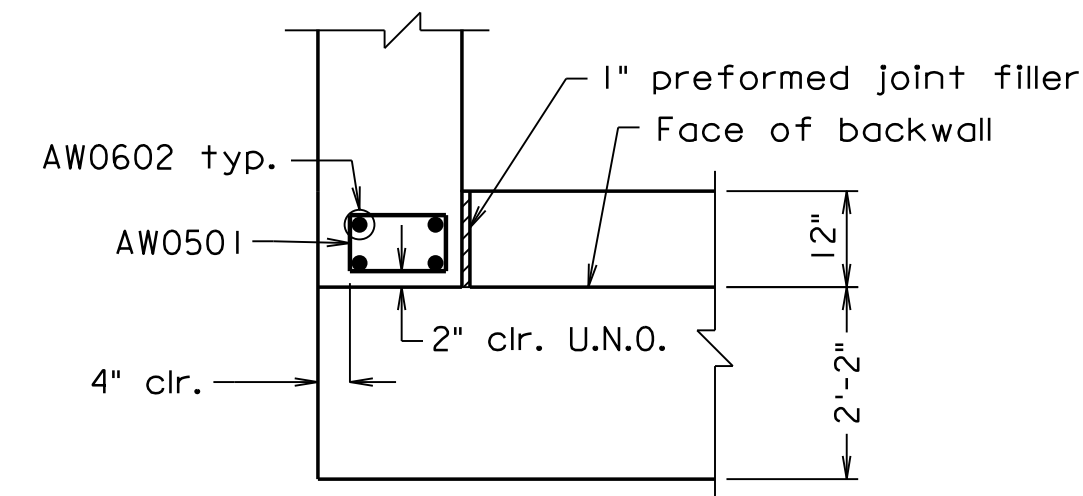

WING HAUNCH DETAILS

Not to Scale

Footing not shown for clarity
Abutment and backwall bars not shown for clarity

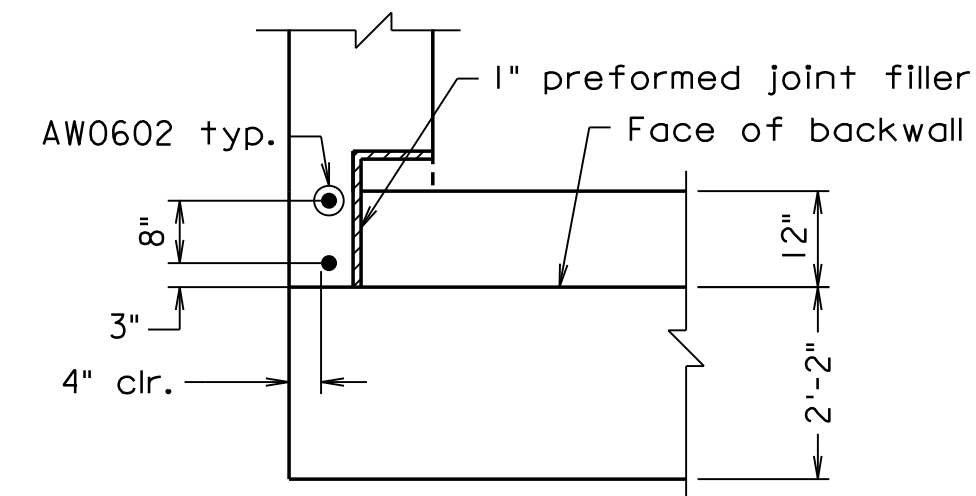

WING HAUNCH DETAILS 2

Not to Scale

Footing not shown for clarity
Abutment and backwall bars not shown for clarity

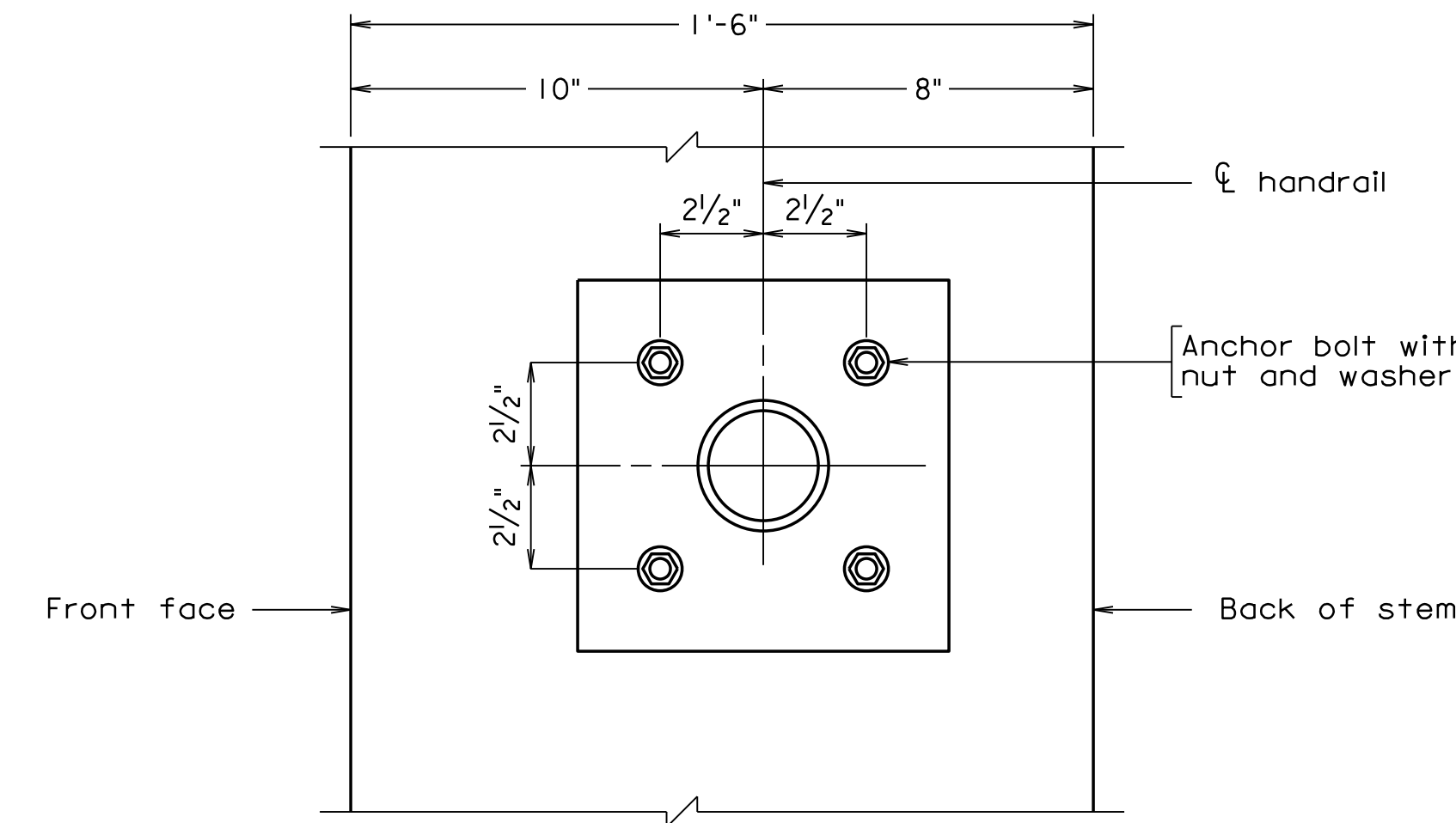

HANDRAIL ANCHOR BOLT DETAILS

Not to Scale

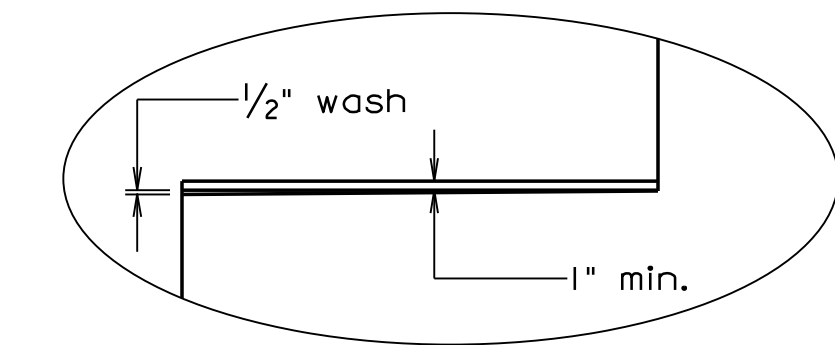

WASH DETAIL

Not to Scale

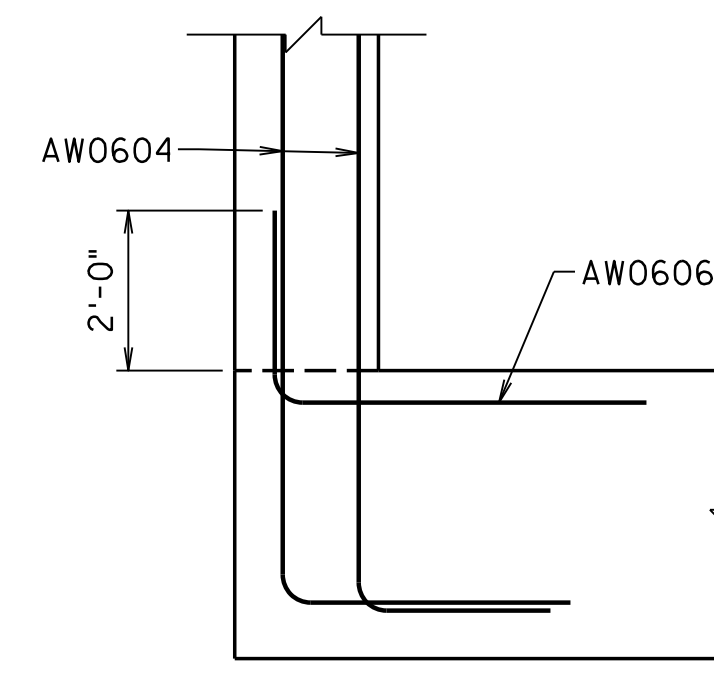

CORNER REINFORCEMENT DETAIL

Not to Scale

Abutment and backwall bars not shown for clarity

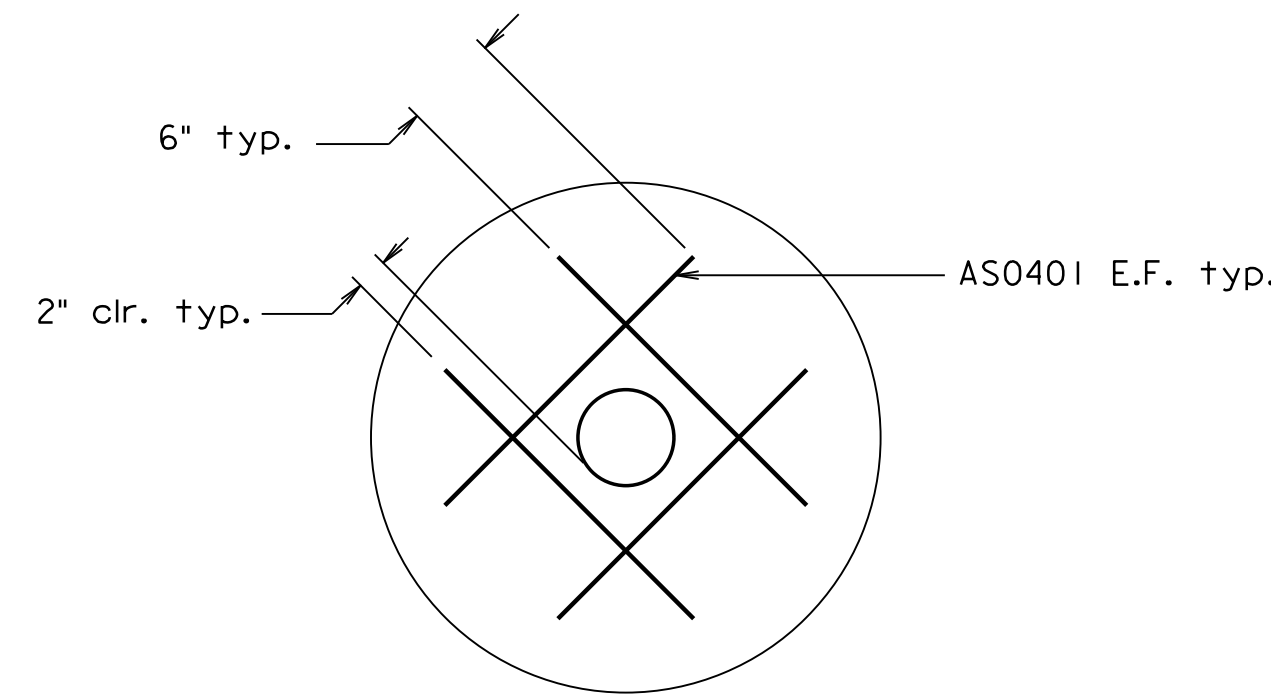

WEEPHOLE REINFORCEMENT DETAIL

Not to Scale

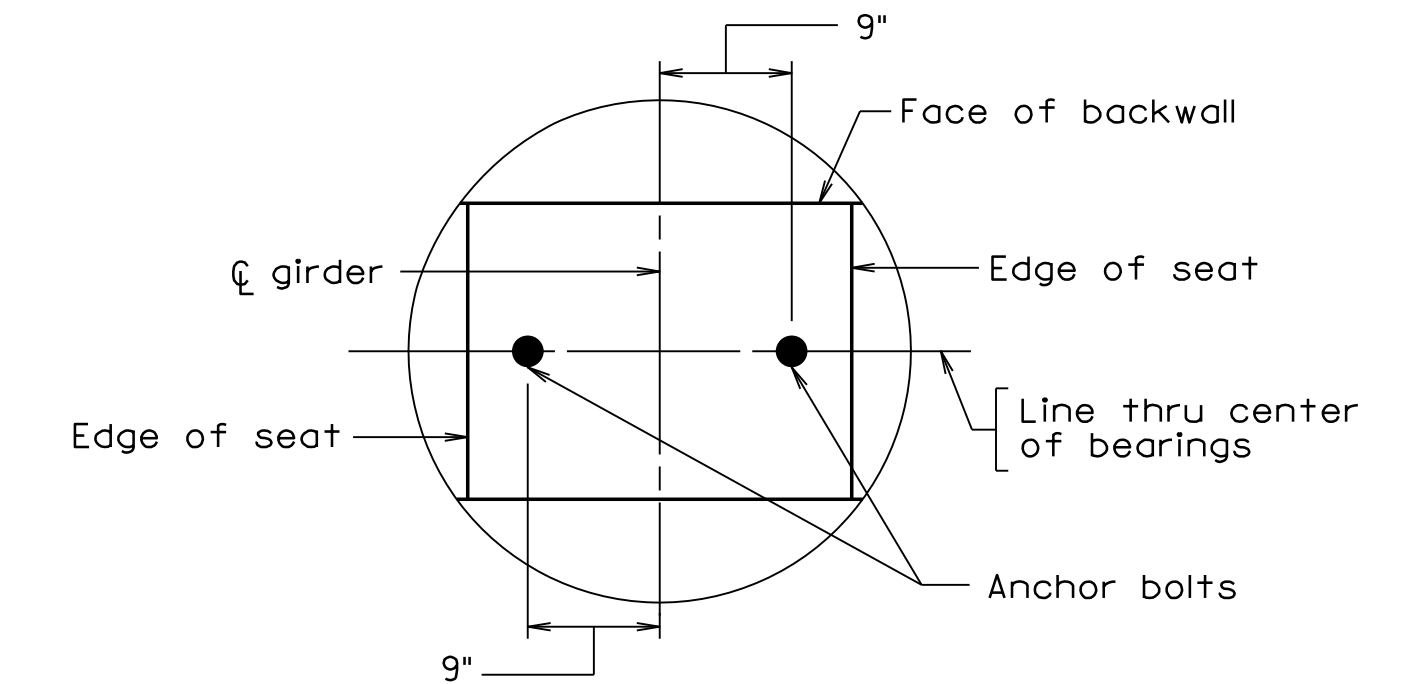

ABUTMENT A ANCHOR BOLT LAYOUT

Not to Scale

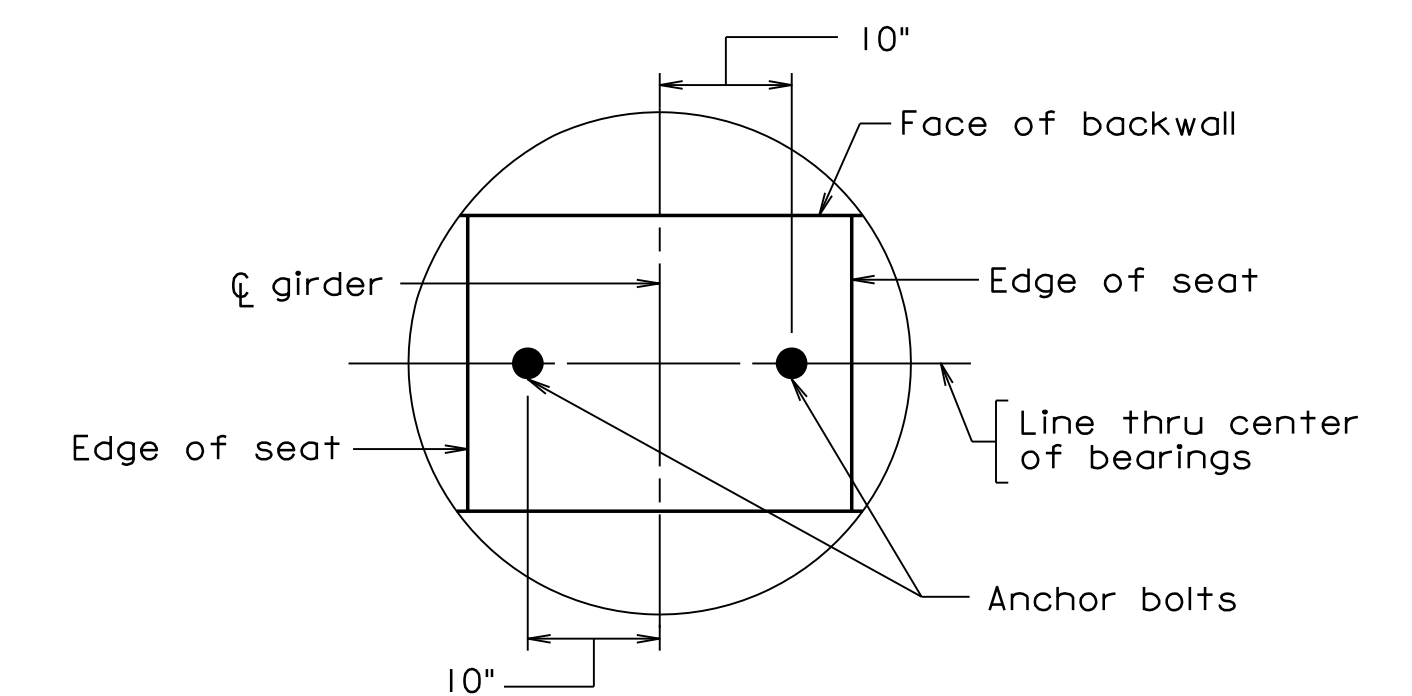

ABUTMENT B ANCHOR BOLT LAYOUT

Not to Scale

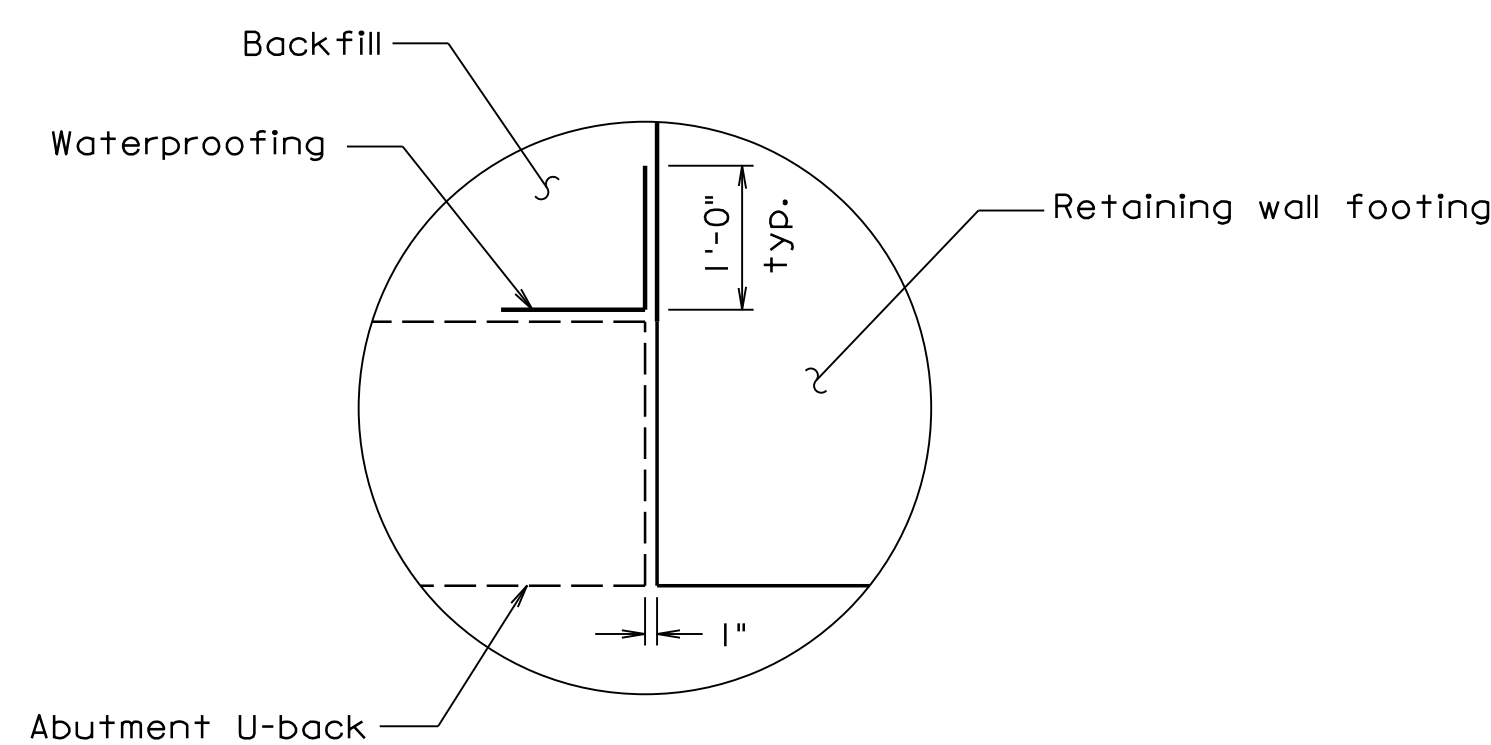

PREFORMED JOINT FILLER - AT FOOTING ELEVATION

Not to Scale

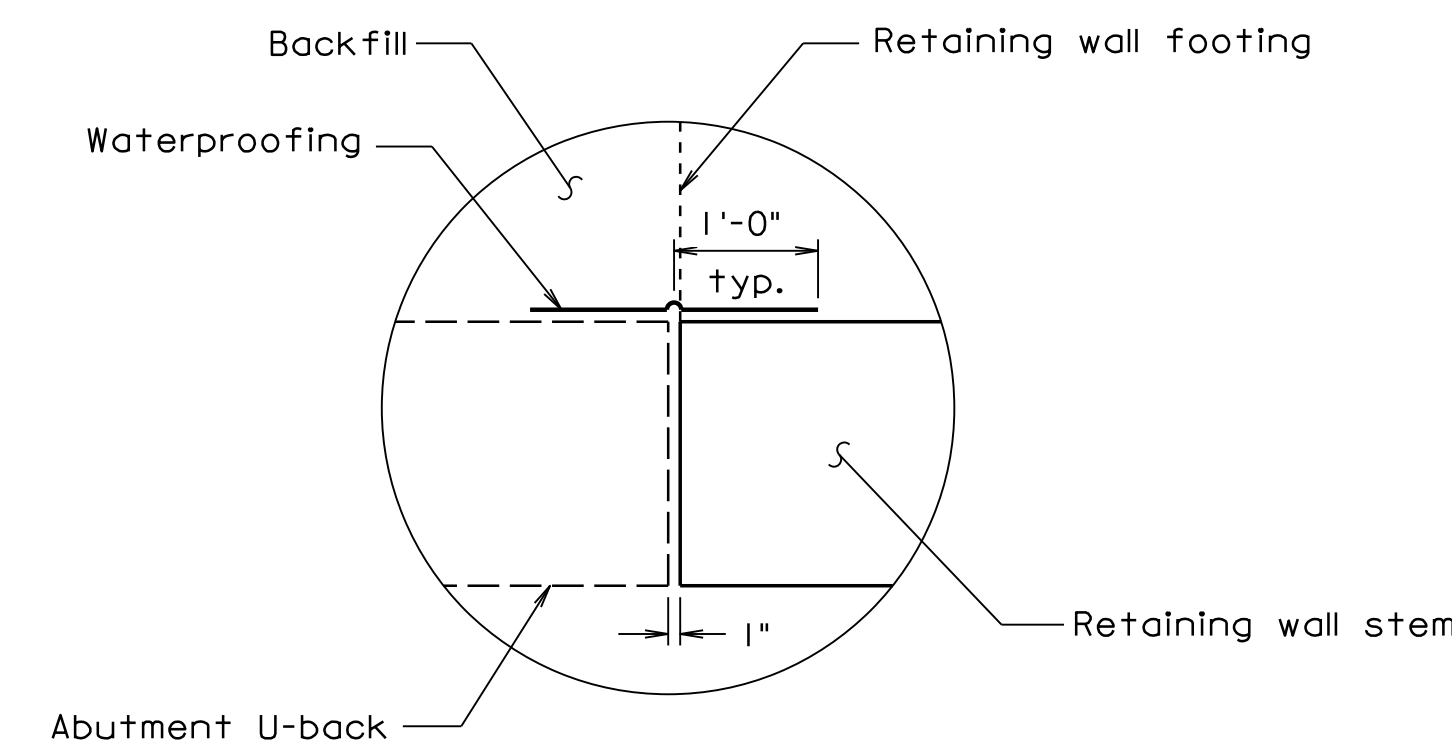

PREFORMED JOINT FILLER - AT STEM ELEVATION

Not to Scale

300-46_13.dgn

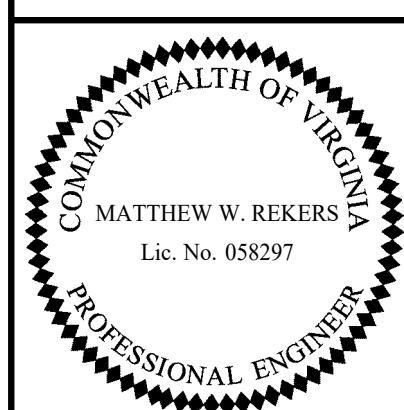

TRANSYSTEMS
RICHMOND, VA
STRUCTURAL ENGINEER

Scale: 1/2" = 1'-0"

© 2023, Commonwealth of Virginia

COMMONWEALTH OF VIRGINIA DEPARTMENT OF TRANSPORTATION					
STRUCTURE AND BRIDGE DIVISION					
ABUTMENT DETAILS					
No.	Description	Date	Designed: S.N.....	Date	Plan No.
			Drawn: V.A.U.....	Apr. 2023	300-46
			Checked: M.W.R.....		13 of 42
Revisions					

STATE	FEDERAL AID	STATE	SHEET
ROUTE	PROJECT	ROUTE	PROJECT
VA.		311	0311-080-913, B618
			14

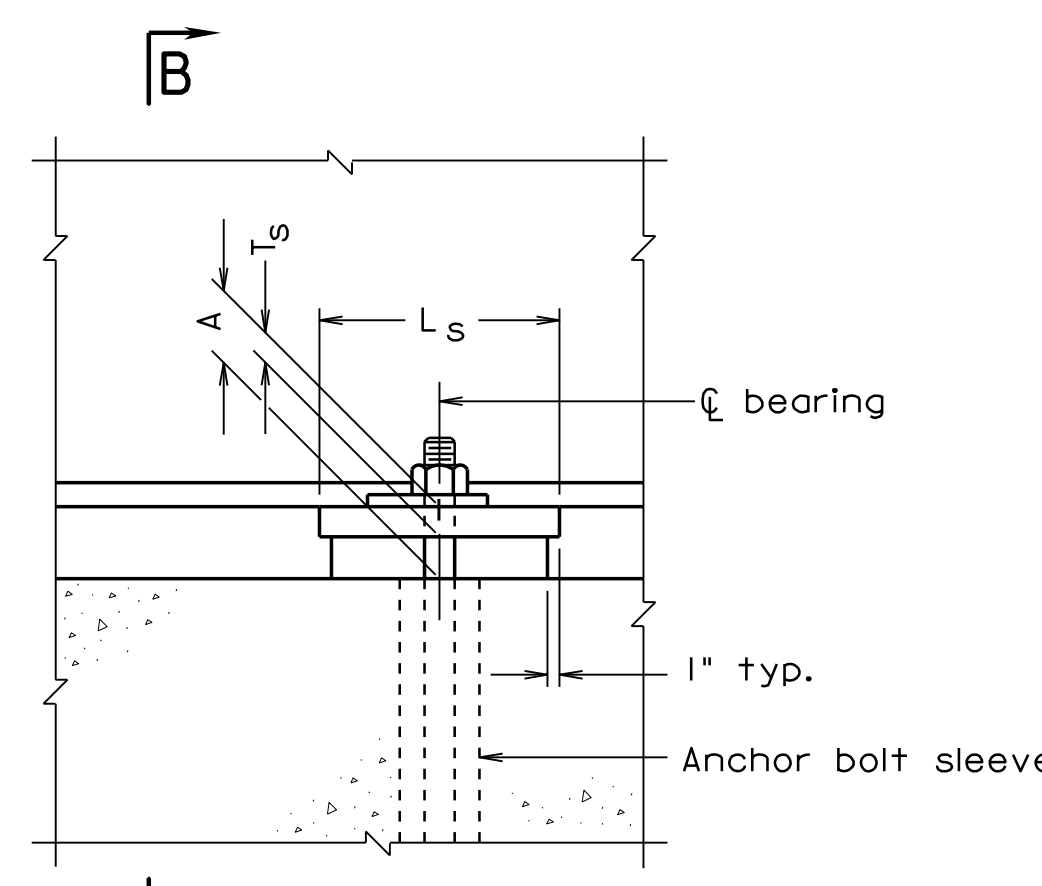

ELEVATION EXPANSION ASSEMBLY

Bearing stiffener(s) not shown for clarity

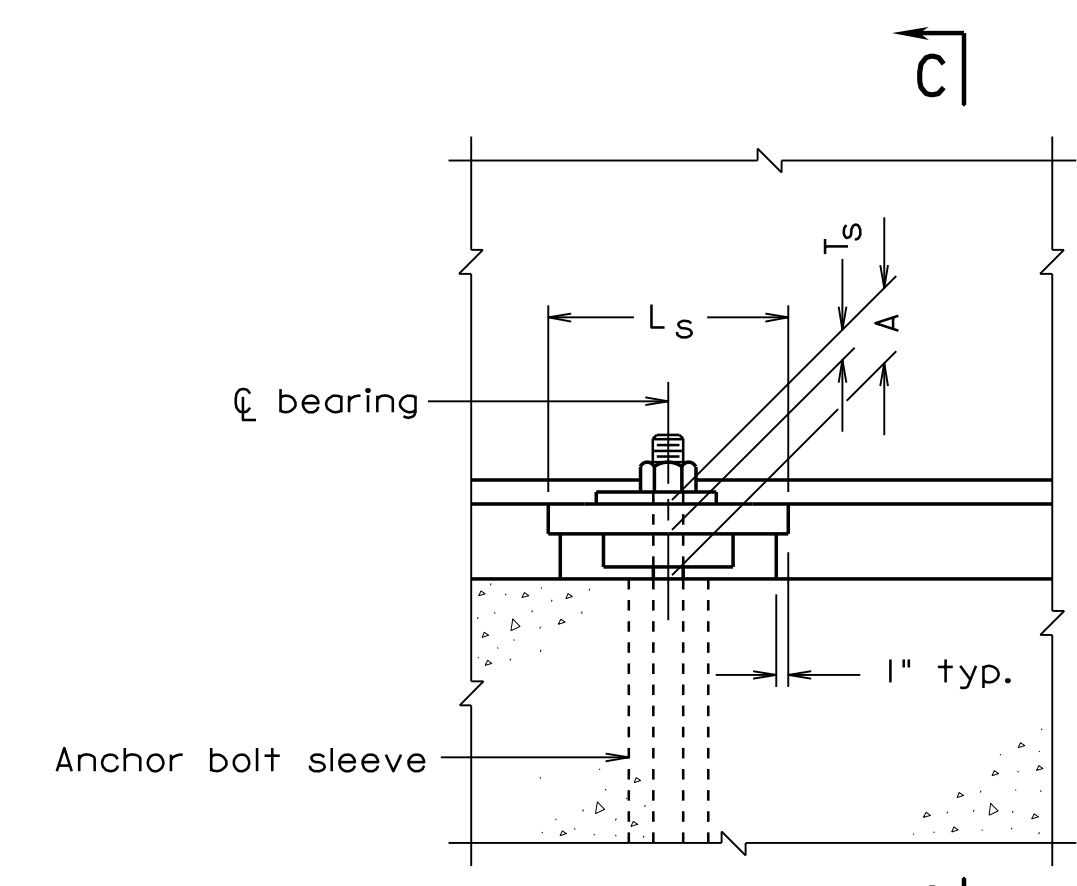

ELEVATION FIXED ASSEMBLY

Bearing stiffener(s) not shown for clarity

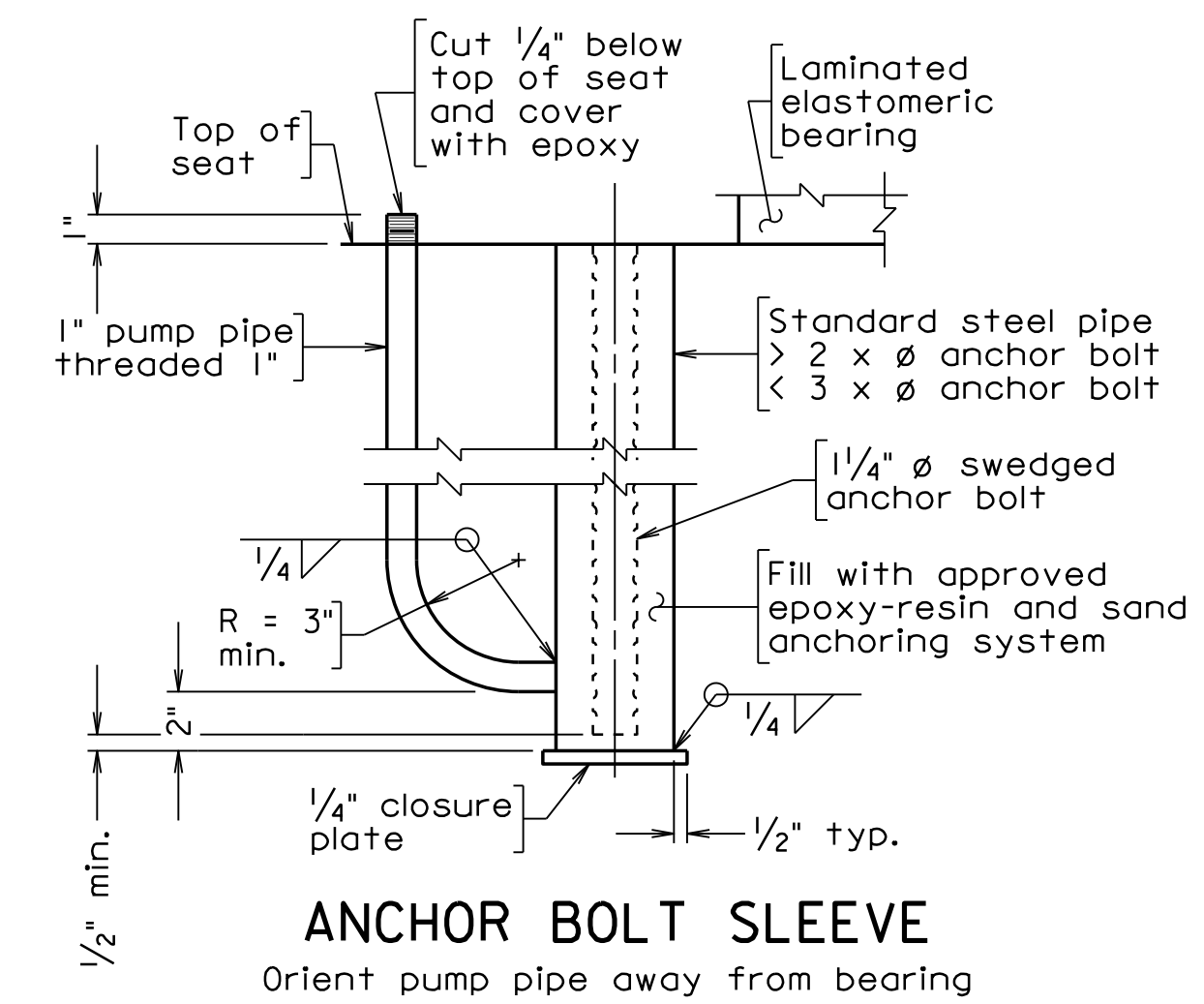

ANCHOR BOLT SLEEVE

Orient pump pipe away from bearing

Notes:

Material: Elastomer - 50 durometer hardness.
Shim - ASTM A36 or A1011 mild steel.
Standard steel pipe - ASTM A53 Grade B.

The Contractor may elect not to provide anchor bolt sleeves at any locations and cast the anchor bolts directly into concrete at their own risk and expense.

Bevel sole plates to grade shown. Plates shall not be painted on the surface in contact with the elastomeric bearing.

Elastomeric bearings shall be molded as a single unit.

Max. horizontal movement is the maximum horizontal superstructure displacement. If the maximum shear deformation of the elastomeric pads exceeds 75% of Max. horizontal movement during construction of the bridge, the Contractor shall reset the bearings at no additional cost to the Department.

* Weld shall terminate 1/4" from edge of sole plate.

** Centerline of girder (including center line and text) shall be marked on the top, bottom and side surfaces of the laminated elastomeric bearing prior to shipping. The markings shall be done with an indelible ink or flexible paint of contrasting color.

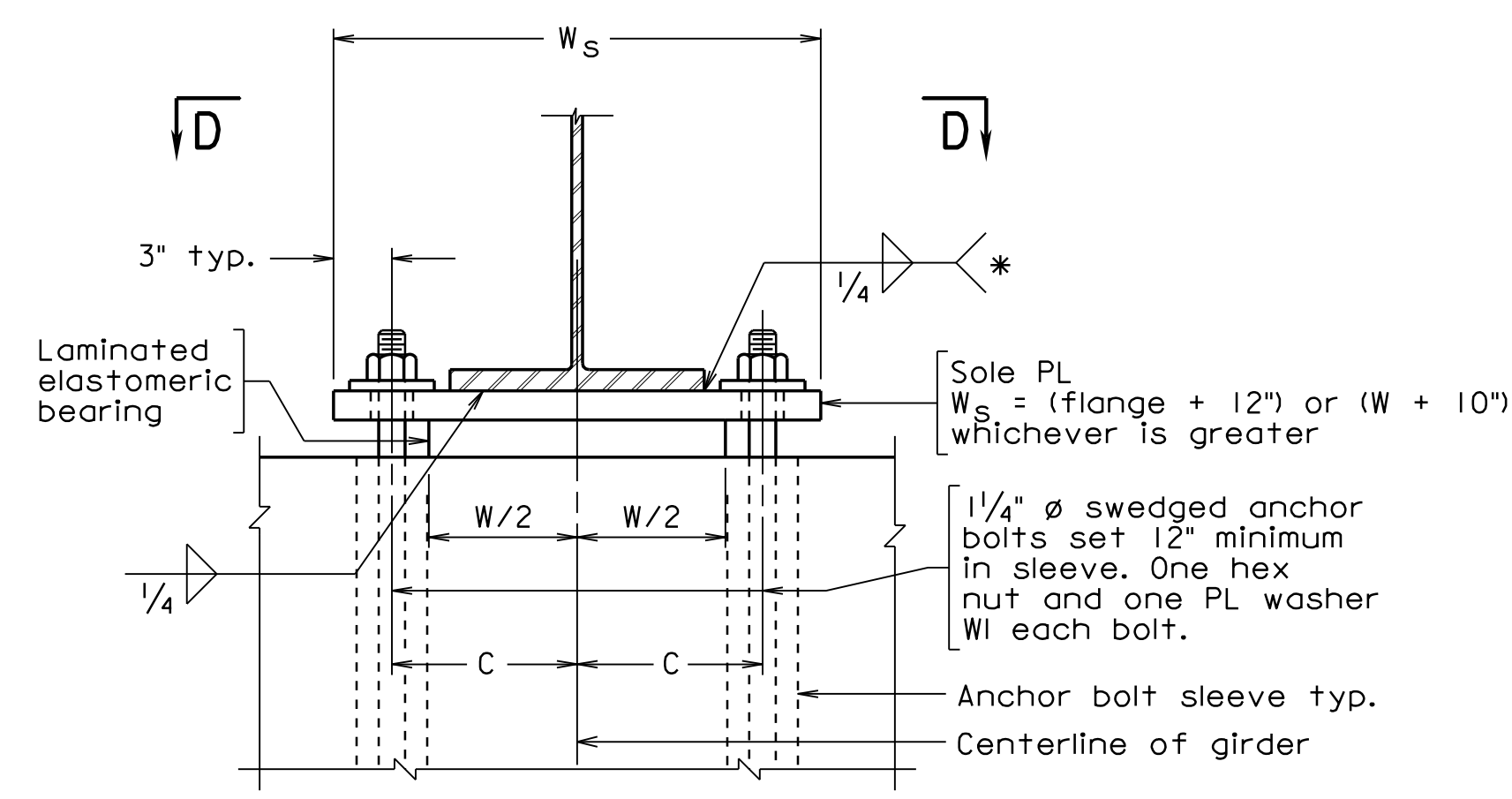

SECTION B-B

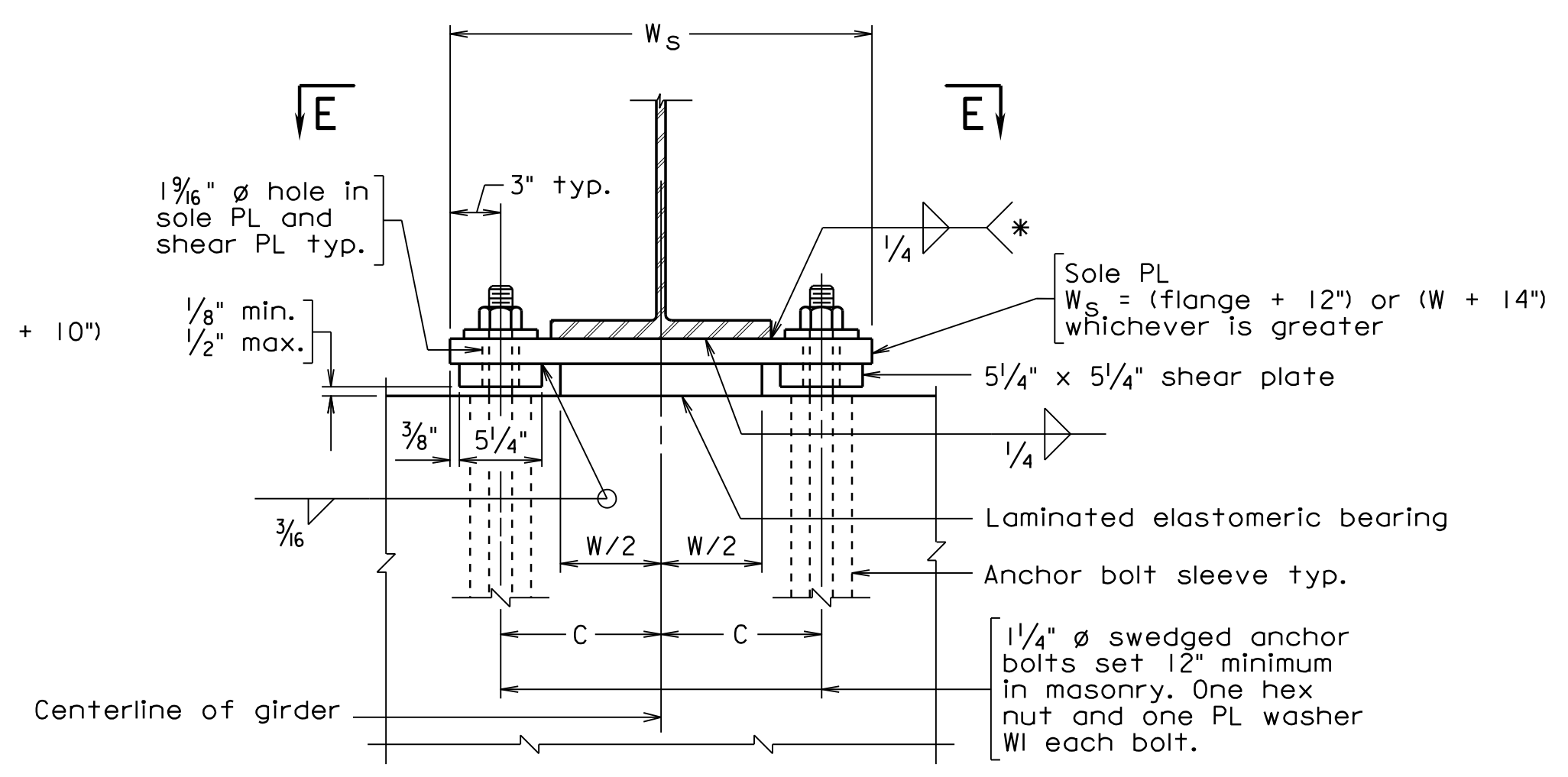

SECTION C-C

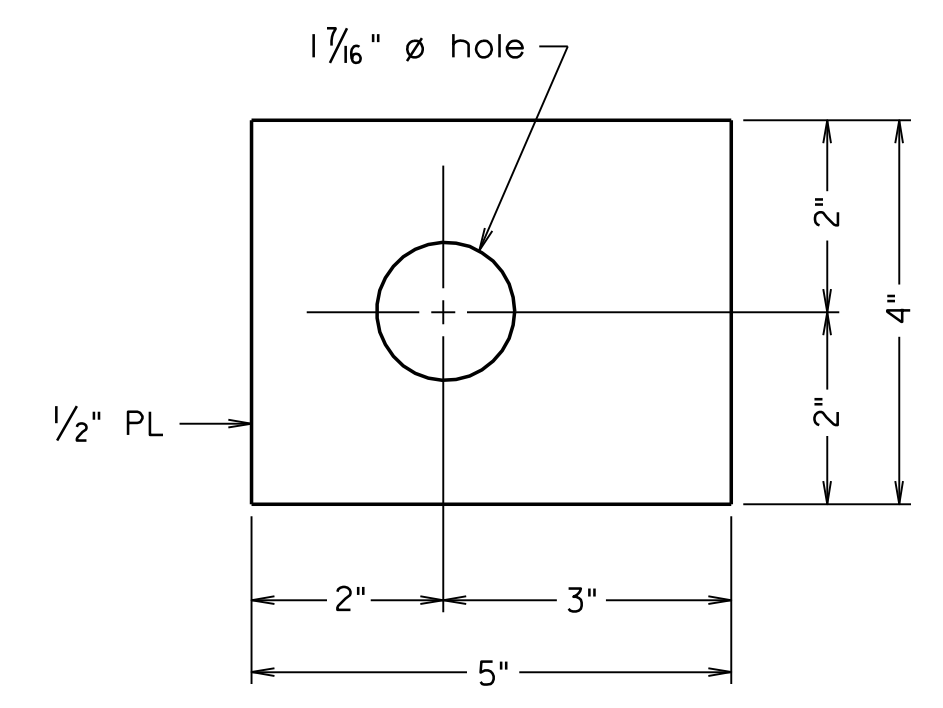

WASHER W1

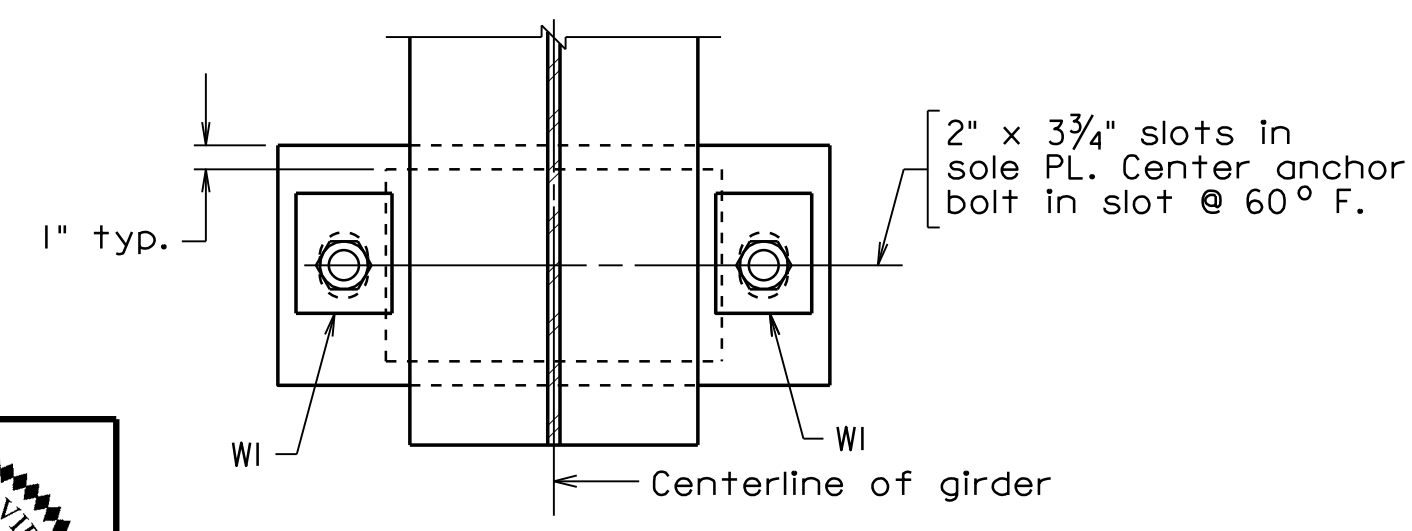

SECTION D-D

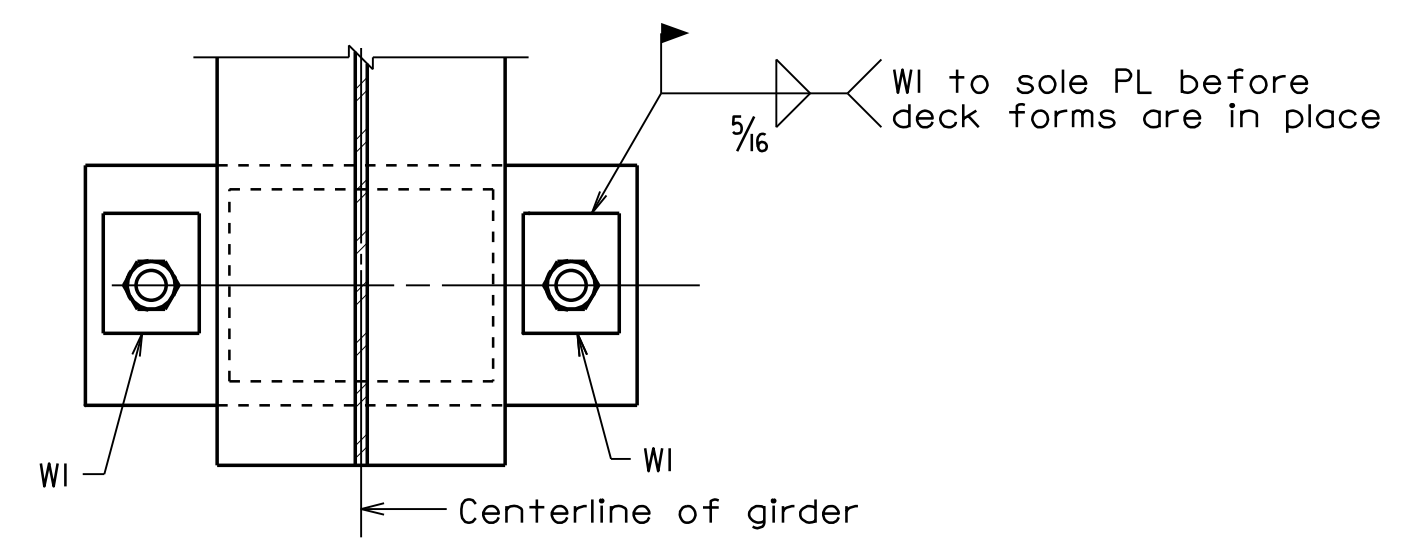

SECTION E-E

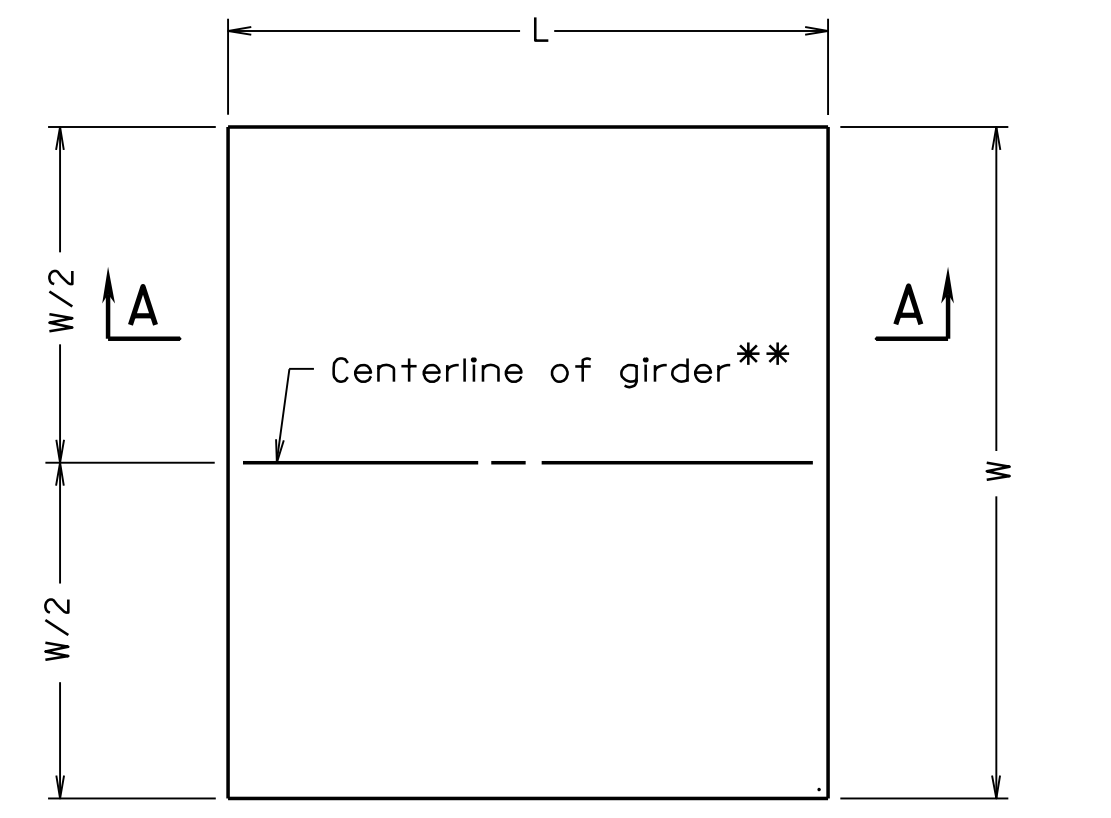

SECTION A-A LAMINATED ELASTOMERIC BEARING

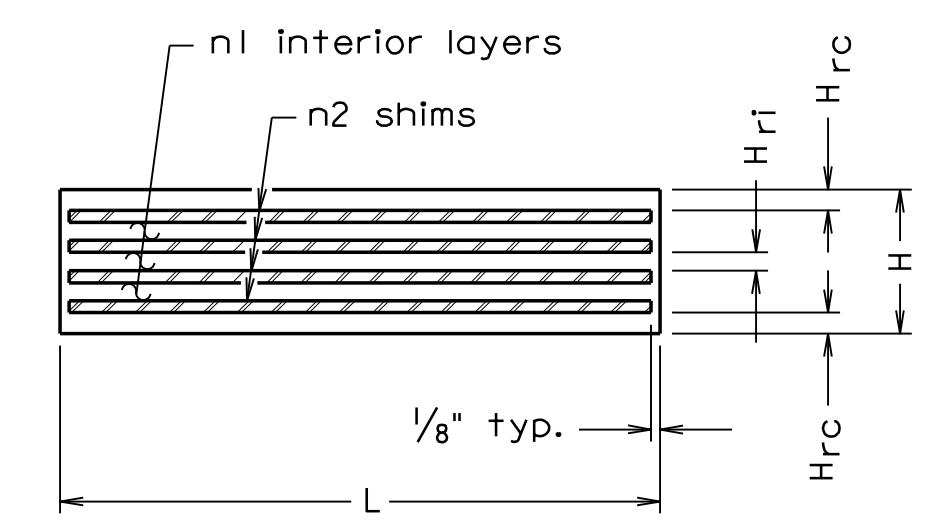

Girder	Abut.	Pier	Bearing type	A	C	Laminated Elastomeric Bearing						Sole Plate			Grade %	Max. Horizontal Movement inches	Vertical Load Service 1 kips
						W	L	H	H _{rc}	n1 @ H _{rl}	n2 @ H _s	W _s	L _s	T _s			
1	A		Exp.	3	9	12	10	2 1/8	1/4	3 @ 3/8	4 @ 1/8	24	12	7/8	1.79	0.66	50
2	A		Exp.	3	9	12	10	2 1/8	1/4	3 @ 3/8	4 @ 1/8	24	12	7/8	1.79	0.66	55
3	A		Exp.	3	9	12	10	2 1/8	1/4	3 @ 3/8	4 @ 1/8	24	12	7/8	1.79	0.66	50
1	B		Fix	3 3/4	10	12	10	2 1/8	1/4	3 @ 3/8	4 @ 1/8	26	12	1 5/8	-1.79	0.66	50
2	B		Fix	3 3/4	10	12	10	2 1/8	1/4	3 @ 3/8	4 @ 1/8	26	12	1 5/8	-1.79	0.66	55
3	B		Fix	3 3/4	10	12	10	2 1/8	1/4	3 @ 3/8	4 @ 1/8	26	12	1 5/8	-1.79	0.66	50

All dimensions in table are in inches.

Not to scale

© 2023, Commonwealth of Virginia

COMMONWEALTH OF VIRGINIA DEPARTMENT OF TRANSPORTATION STRUCTURE AND BRIDGE DIVISION					
BEARING DETAILS					
No.	Description	Date	Designed: S.N.	Date	Plan No.
	Revisions		Drawn: S&B, DIV	Apr. 2023	300-46
			Checked: M.W.R.		14 of 42

300-46_14.dgn

10-30-2020

BBD-9

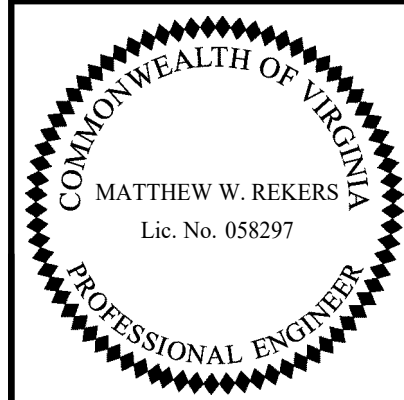

TRANSYSTEMS
RICHMOND, VA
STRUCTURAL ENGINEER

Sealed and Signed by:
Junyi Meng
Lic. No. 033572
On the date of
October 30, 2020

A copy of the original
sealed and signed
drawing is on file in the
Central Office.

VDOT S&B DIVISION
RICHMOND, VA
STRUCTURAL ENGINEER

STATE	FEDERAL AID	STATE	SHEET
ROUTE	PROJECT	ROUTE	PROJECT
VA.		311	0311-080-913, B618
			15

Notes:

For additional reinforcing steel details not shown, see Deck Slab Plan on sheet 20.

For details of parapet, see sheets 22 and 23.

For Pedestrian Fence Details, see sheet 24.

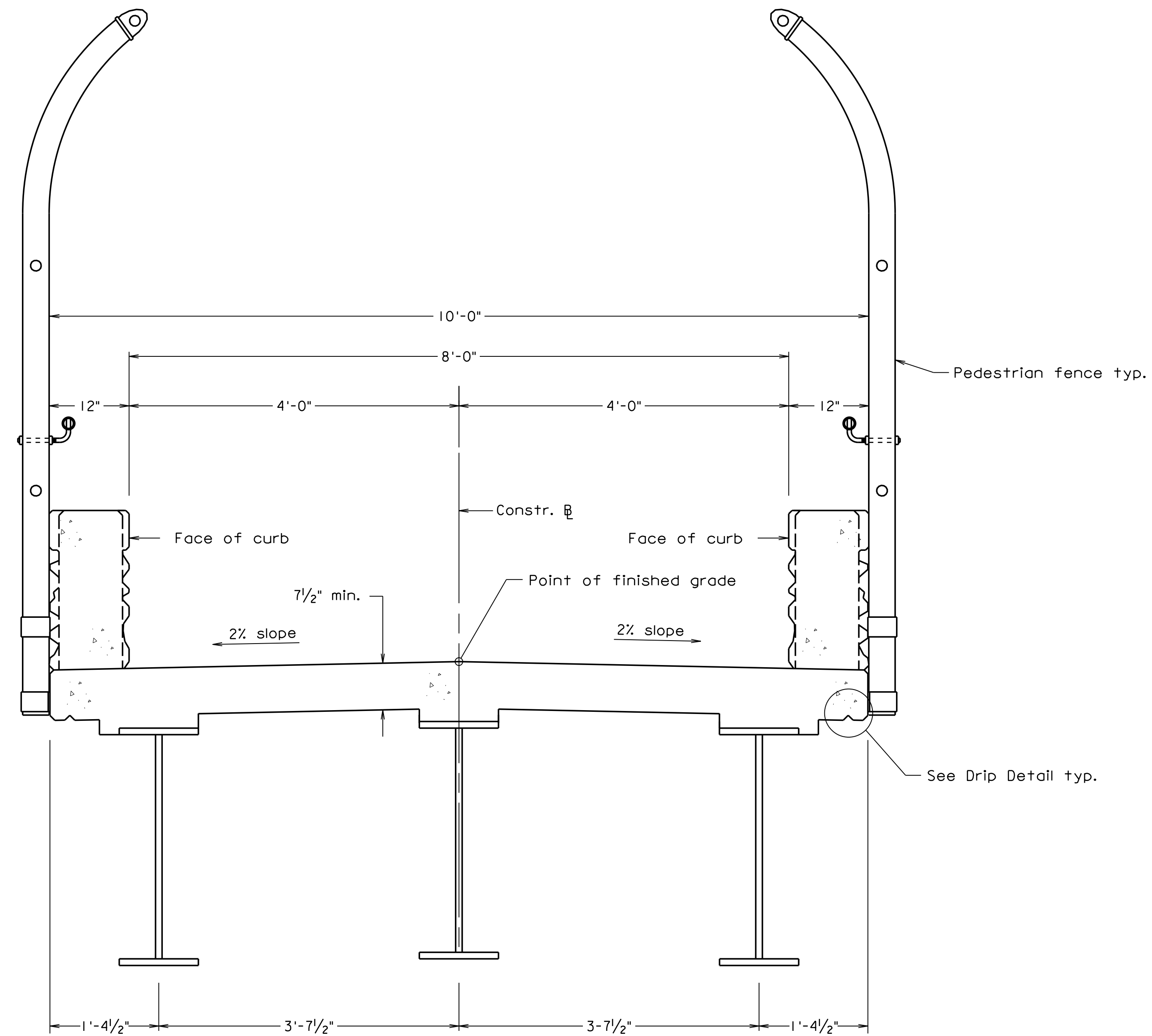

TRANSVERSE SECTION

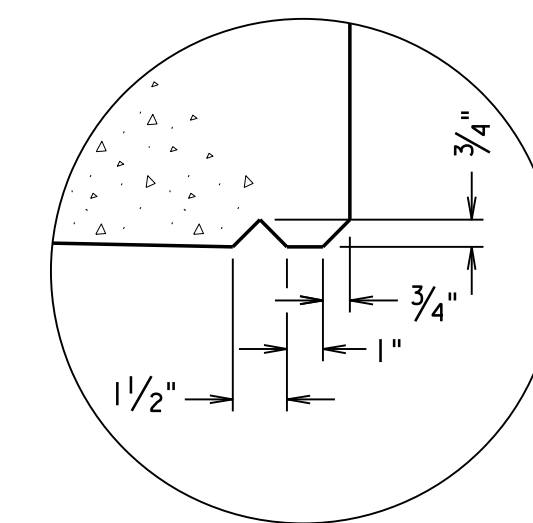

DRIP DETAIL
Scale: 2" = 1'-0"

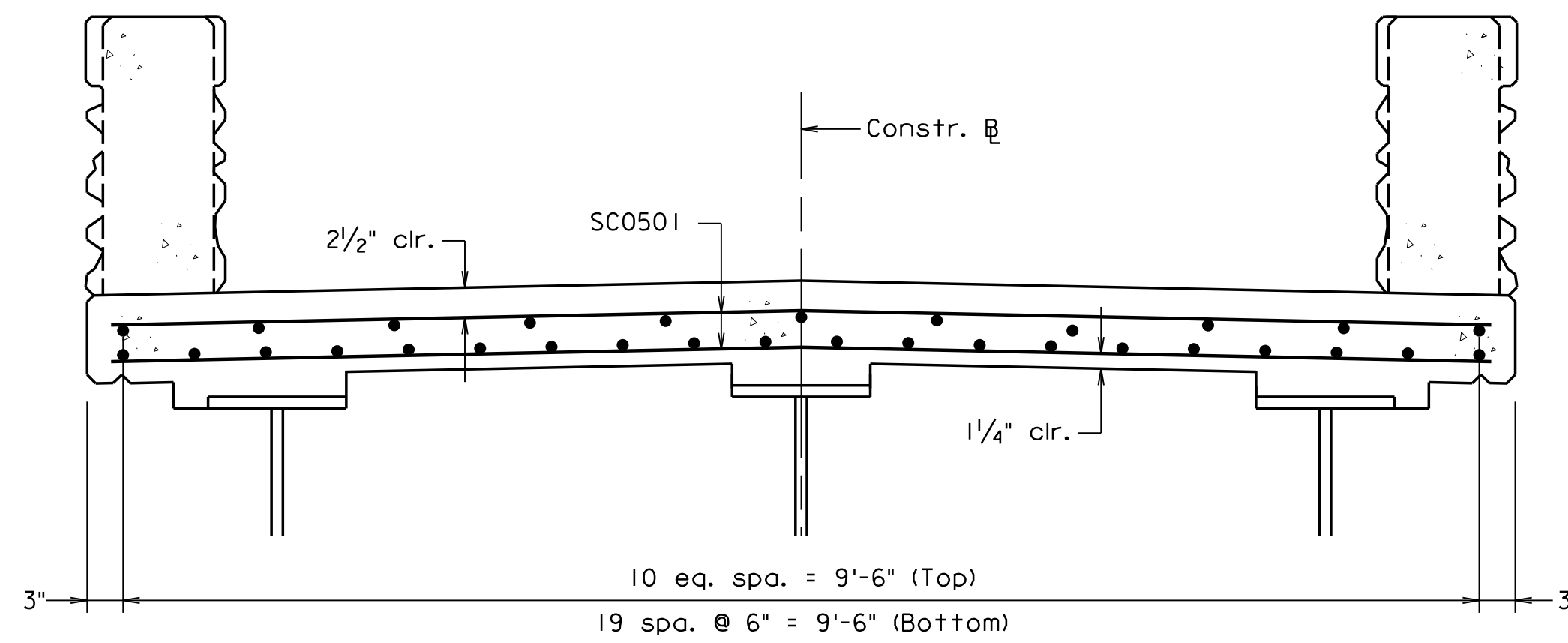

DECK REINFORCEMENT

Pedestrian fence not shown for clarity

Scale: 1" = 1'-0" Unless Noted Otherwise

© 2023, Commonwealth of Virginia

COMMONWEALTH OF VIRGINIA DEPARTMENT OF TRANSPORTATION					
STRUCTURE AND BRIDGE DIVISION					
TRANSVERSE SECTION					
No.	Description	Date	Designed: S.N.....	Date	Plan No.
			Drawn: V.A.U.....	Apr. 2023	300-46
			Checked: M.W.B.....		15 of 42
Revisions					

300-46_15.dgn

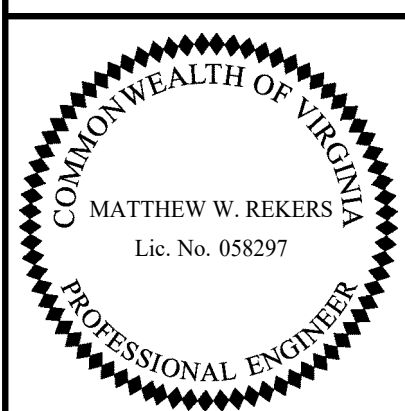

TRANSYSTEMS
RICHMOND, VA
STRUCTURAL ENGINEER

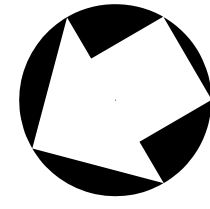

STATE	FEDERAL AID		STATE		SHEET
ROUTE	PROJECT		ROUTE	PROJECT	NO.
VA.			311	0311-080-913, B618	16

Notes:
For girder details, see sheet 17.

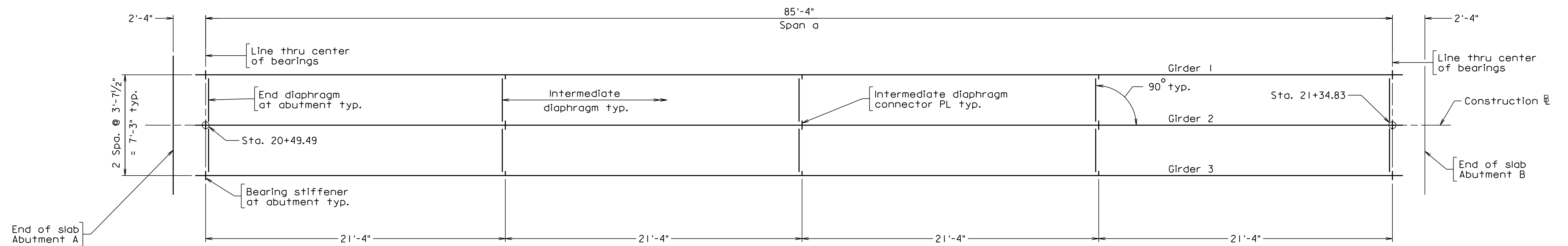

FRAMING PLAN

300-46_16.dgn

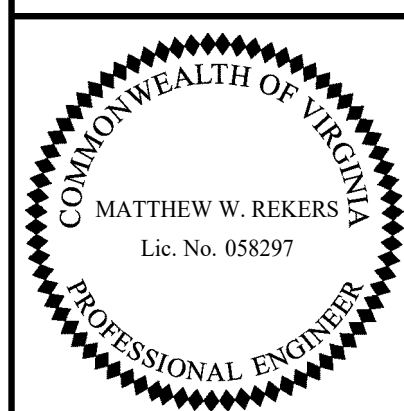

TRANSYSTEMS
RICHMOND, VA
STRUCTURAL ENGINEER

COMMONWEALTH OF VIRGINIA DEPARTMENT OF TRANSPORTATION					
STRUCTURE AND BRIDGE DIVISION					
FRAMING PLAN					
No.	Description	Date	Designed: S.N.....	Date	Plan No.
			Drawn: V.A.U.....	Apr. 2023	300-46
			Checked: M.W.R.....		16 of 42
Revisions					

Scale: 1/4" = 1'-0" © 2023, Commonwealth of Virginia

STATE	FEDERAL AID	STATE	SHEET
ROUTE	PROJECT	ROUTE	PROJECT
VA.		311	0311-080-913, B618
			17

Notes:
 For spacing of intermediate diaphragm connector plates, see Framing Plan, sheet 16.
 The bottom flanges as shown in Girder Elevation and the web are areas of tensile stress for Charpy V-Notch impact requirements.
 Symbol ϕ = diameter.

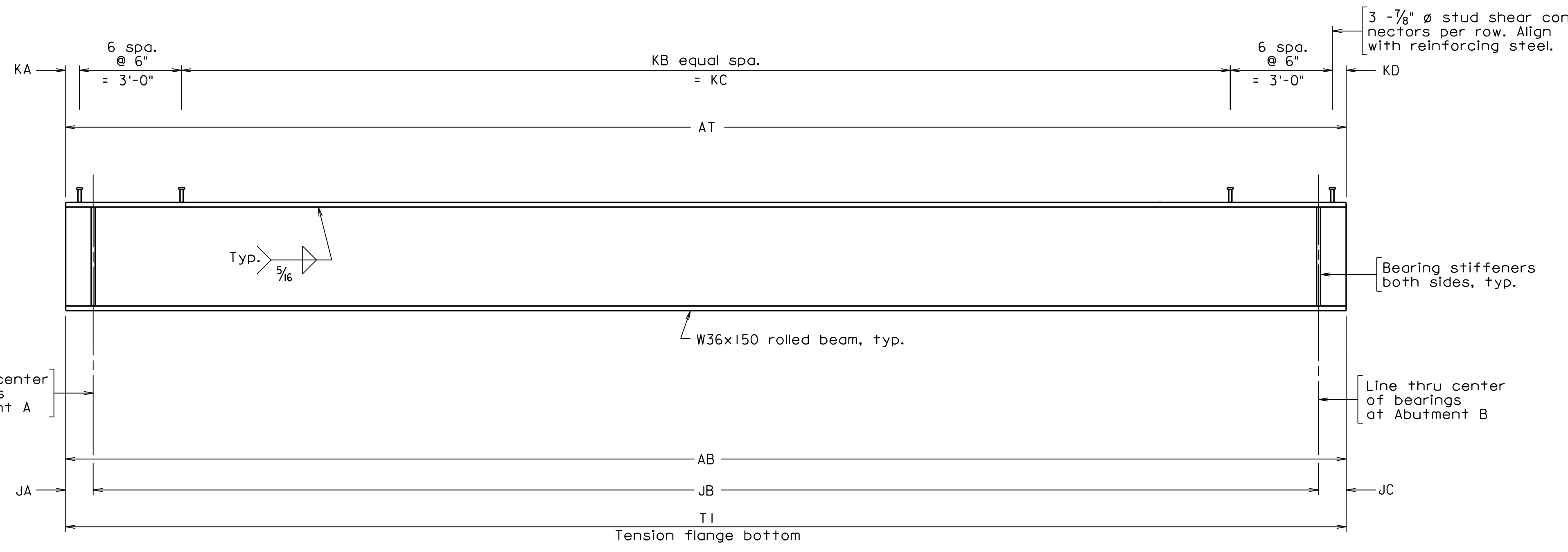

GIRDER ELEVATION

Girder	AB	AT
ALL	86'-10"	86'-10"

Girder	JA	JB	JC	KA	KB	KC	KD
ALL	9"	85'-4"	9"	4"	81	80'-2"	4"

Girder	T1
ALL	86'-10"

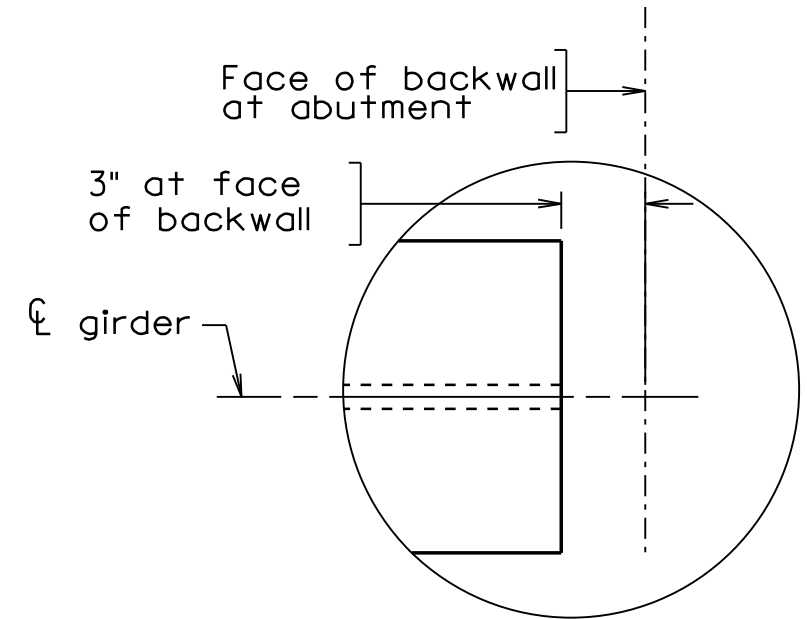

GIRDER END DETAILS

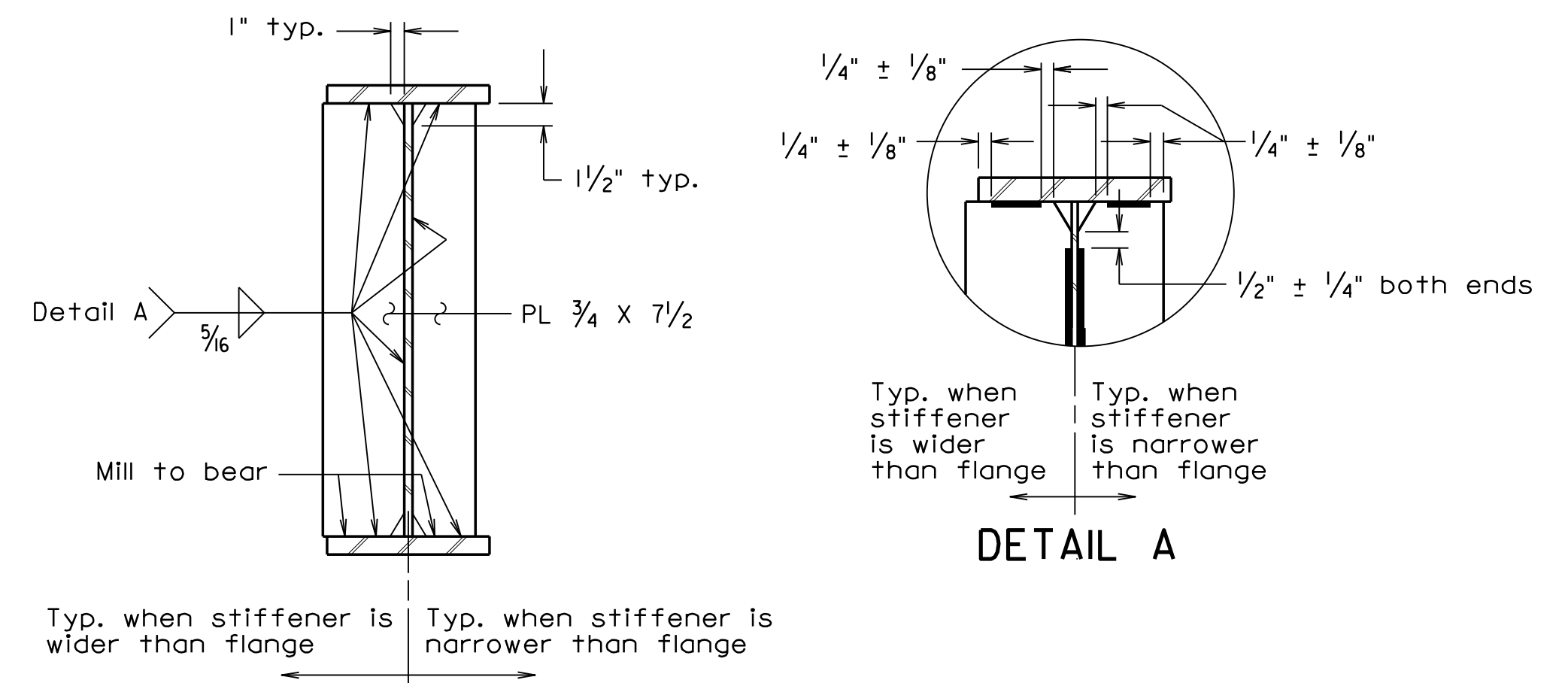

BEARING STIFFENERS

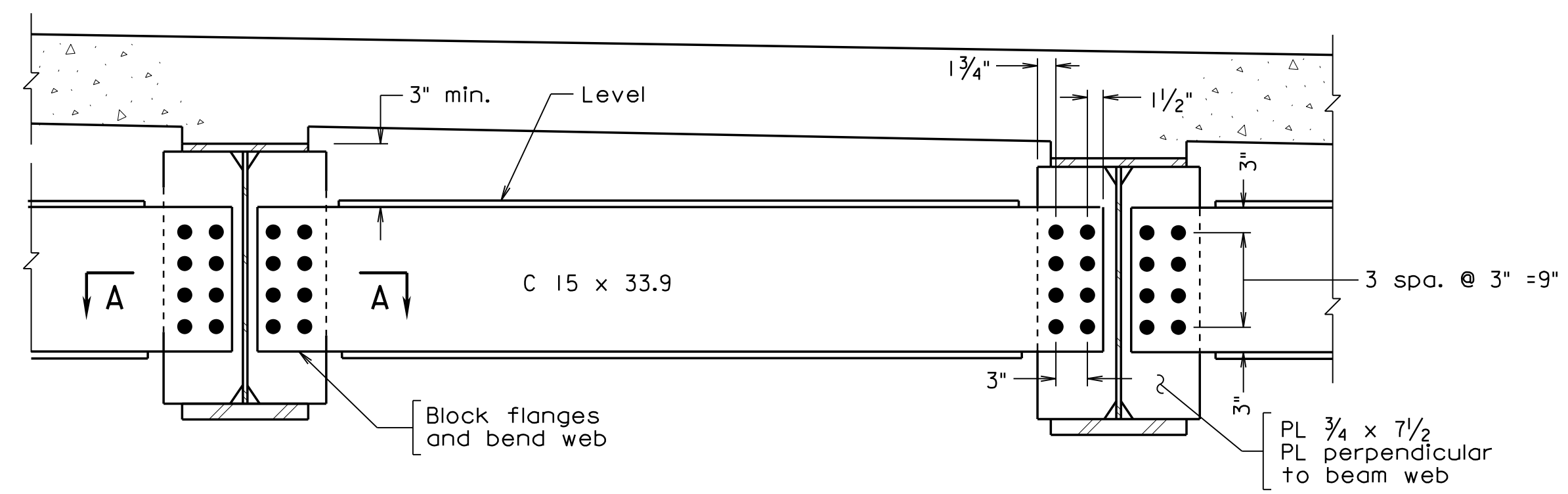

DIAPHRAGMS

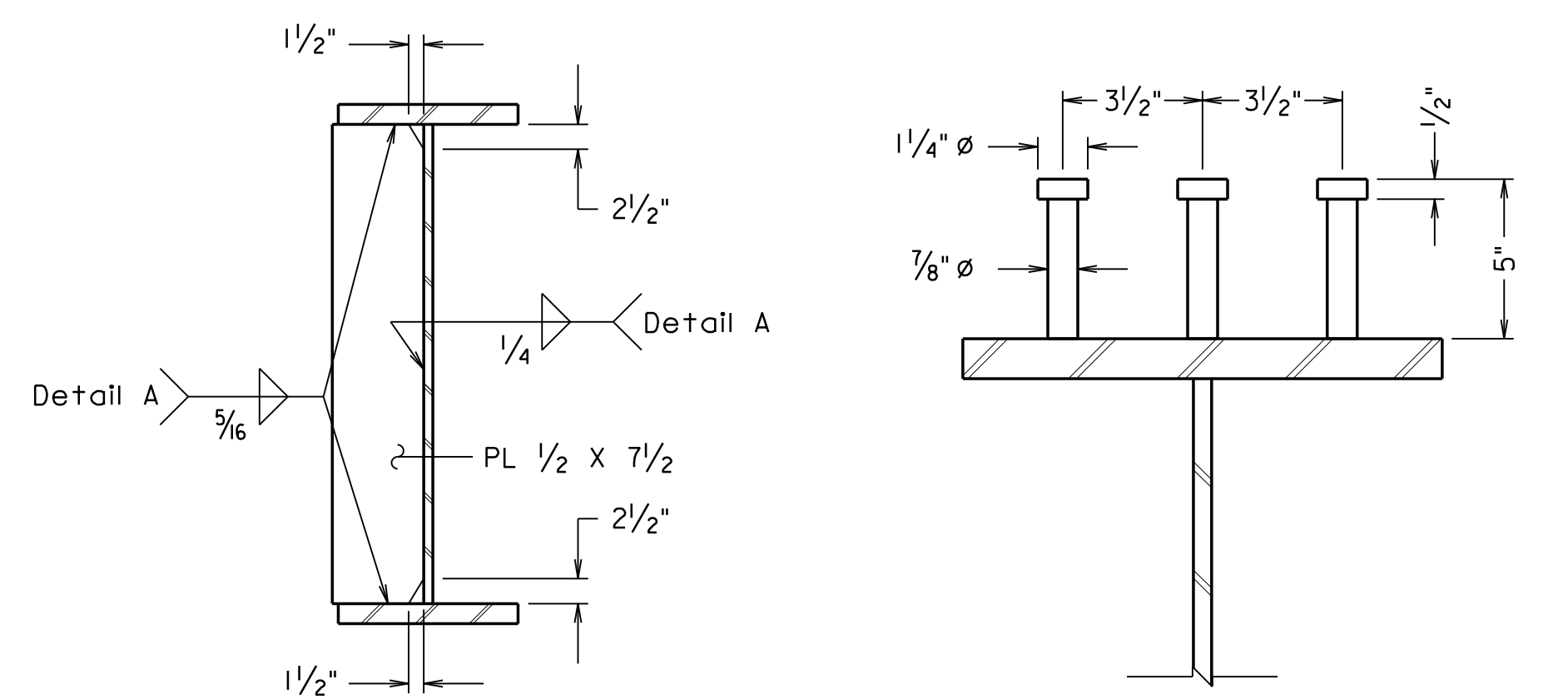

INTERMEDIATE DIAPHRAGM CONNECTOR PLATE

TYPICAL SHEAR STUD CONNECTOR DETAILS

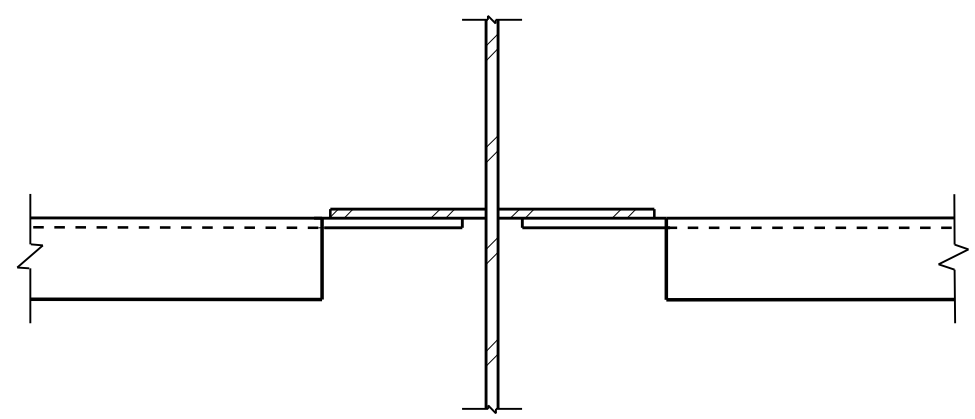

SECTION A-A

Not to Scale

Not to scale unless otherwise noted

© 2023, Commonwealth of Virginia

COMMONWEALTH OF VIRGINIA DEPARTMENT OF TRANSPORTATION STRUCTURE AND BRIDGE DIVISION			
GIRDER DETAILS			
No.	Description	Date	Revisions
Designed: S.N.	Date	Plan No.	Sheet No.
Drawn: V.A.U.	Apr. 2023	300-46	17 of 42
Checked: M.W.B.			

300-46_17.dgn

SGDET I Mod. 04-30-2020



TRANSYSTEMS
RICHMOND, VA
STRUCTURAL ENGINEER

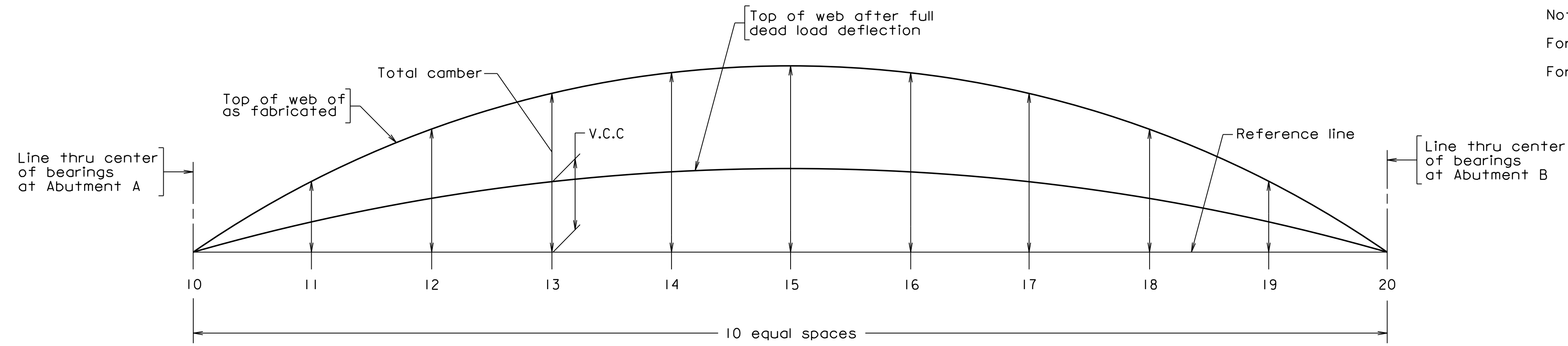

Notes:
 For girder details, see sheet 17.
 For dead load deflections and top of slab elevations, see sheet 19.

	Point	10	11	12	13	14	15	16	17	18	19	20
Girder 1	Δ_s	0	1/4"	7/16"	5/8"	3/4"	3/4"	3/4"	5/8"	7/16"	1/4"	0
	Δ'_s	0	9/16"	1 1/16"	1 7/16"	1 11/16"	1 13/16"	1 11/16"	1 7/16"	1 1/16"	9/16"	0
	Δ_c	0	1/4"	7/16"	9/16"	11/16"	11/16"	11/16"	9/16"	7/16"	1/4"	0
	V.C.C.	0	1 3/4"	3 1/8"	4 1/16"	4 11/16"	4 7/8"	4 11/16"	4 1/16"	3 1/8"	1 3/4"	0
	Total	0	2 3/4"	5 1/16"	6 3/4"	7 3/4"	8 1/8"	7 3/4"	6 3/4"	5 1/16"	2 3/4"	0
Girder 2	Δ_s	0	1/4"	1/2"	5/8"	3/4"	13/16"	3/4"	5/8"	1/2"	1/4"	0
	Δ'_s	0	5/8"	1 3/16"	1 5/8"	1 7/8"	2"	1 7/8"	1 5/8"	1 3/16"	5/8"	0
	Δ_c	0	3/16"	3/8"	9/16"	5/8"	1 1/16"	5/8"	9/16"	3/8"	3/16"	0
	V.C.C.	0	1 3/4"	3 1/8"	4 1/16"	4 11/16"	4 7/8"	4 11/16"	4 1/16"	3 1/8"	1 3/4"	0
	Total	0	2 13/16"	5 3/16"	6 7/8"	7 15/16"	8 5/16"	7 15/16"	6 7/8"	5 3/16"	2 13/16"	0
Girder 3	Δ_s	0	1/4"	7/16"	5/8"	3/4"	3/4"	3/4"	5/8"	7/16"	1/4"	0
	Δ'_s	0	9/16"	1 1/16"	1 7/16"	1 11/16"	1 13/16"	1 11/16"	1 7/16"	1 1/16"	9/16"	0
	Δ_c	0	1/4"	7/16"	9/16"	11/16"	11/16"	11/16"	9/16"	7/16"	1/4"	0
	V.C.C.	0	1 3/4"	3 1/8"	4 1/16"	4 11/16"	4 7/8"	4 11/16"	4 1/16"	3 1/8"	1 3/4"	0
	Total	0	2 3/4"	5 1/16"	6 3/4"	7 3/4"	8 1/8"	7 3/4"	6 3/4"	5 1/16"	2 3/4"	0

CAMBER DIAGRAM

Reference line = line between top of web at abutment A and top of web at abutment B (C bearing to C bearing).
 Δ_s = Deflection of girder from its own weight after erection including diaphragms, connectors, etc.
 Δ'_s = Deflection of girder from dead load of concrete deck slab, bolster and construction tolerance.
 Δ_c = Deflection of girder from permanent dead load added after deck slab is cast (e.g. parapet).
 V.C.C. = Vertical curve camber = Distance between the reference line and top of web after full dead load deflection.
 Total camber = $\Delta_s + \Delta'_s + \Delta_c + V.C.C.$

Sign convention: Deflections are positive if downward; negative if upward.

V.C.C. is positive if the top of web after full dead load deflection is above the reference line; and negative if below the reference line.

Total camber is positive if the top of web as fabricated is above the reference line; and negative if below the reference line.

Diagram depicts all values being positive, and is not meant to reflect actual conditions.

300-46_18.dgn

SGCAMI Mod. 04-30-2020

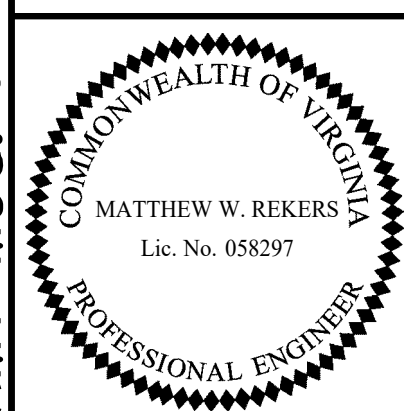

TRANSYSTEMS
 RICHMOND, VA
 STRUCTURAL ENGINEER

COMMONWEALTH OF VIRGINIA DEPARTMENT OF TRANSPORTATION					
STRUCTURE AND BRIDGE DIVISION					
CAMBER DIAGRAM					
No.	Description	Date	Designed: S.N.....	Date	Plan No.
			Drawn: V.A.U.....	Apr. 2023	300-46
			Checked: M.W.R.....		18 of 42
Revisions					

Not to scale

© 2023, Commonwealth of Virginia

STATE	FEDERAL AID		STATE		SHEET
ROUTE	PROJECT		ROUTE	PROJECT	NO.
VA.			311	0311-080-913, B618	19

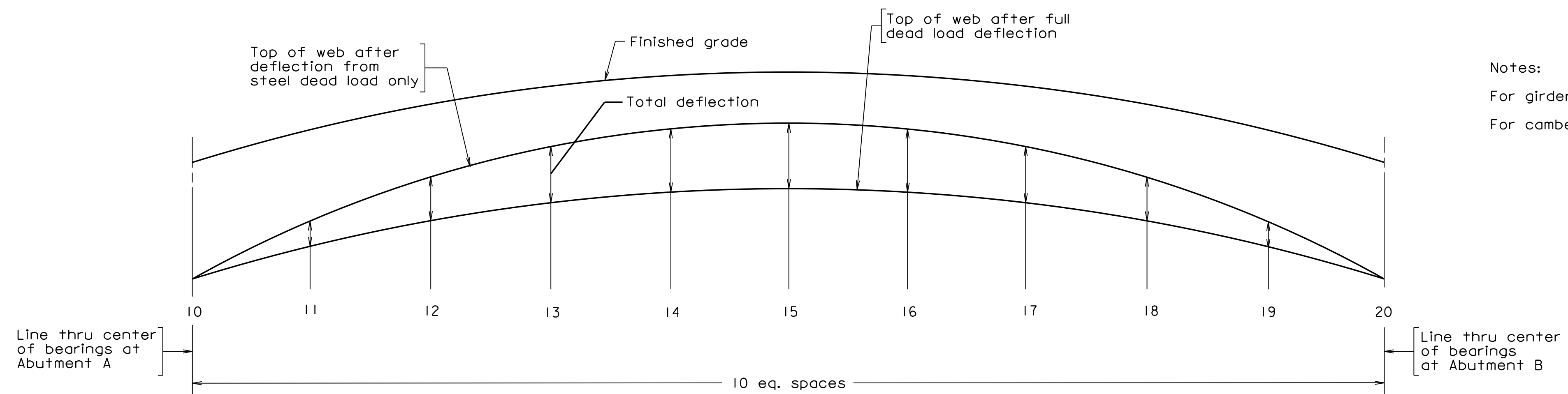

Notes:
 For girder details, see sheet 17.
 For camber diagram, see sheet 18.

	Point	10	11	12	13	14	15	16	17	18	19	20
Girders 1 & 3	Δ_s	0	9/16"	1 1/16"	1 7/16"	1 11/16"	1 13/16"	1 11/16"	1 7/16"	1 1/16"	9/16"	0
	Δ_c	0	1/4"	7/16"	9/16"	11/16"	11/16"	11/16"	9/16"	7/16"	1/4"	0
	Total	0	13/16"	1 1/2"	2"	2 3/8"	2 1/2"	2 3/8"	2"	1 1/2"	13/16"	0
Girder 2	Δ_s	0	5/8"	1 3/16"	1 5/8"	1 7/8"	2"	1 7/8"	1 5/8"	1 3/16"	5/8"	0
	Δ_c	0	3/16"	3/8"	9/16"	5/8"	5/8"	5/8"	9/16"	3/8"	3/16"	0
	Total	0	13/16"	1 9/16"	2 3/16"	2 1/2"	2 5/8"	2 1/2"	2 3/16"	1 9/16"	13/16"	0

DEAD LOAD DEFLECTIONS

All values in Dead Load Deflection Table are in inches.
 Δ_s = Deflection of girder from dead load of concrete deck slab, bolster and construction tolerances.
 Δ_c = Deflection of girder from permanent dead load added after deck slab is cast (e.g. parapet).

TOP OF SLAB ELEVATIONS ALONG \bar{C} GIRDER											
Point	10	11	12	13	14	15	16	17	18	19	20
Girder 1	1980.32	1980.47	1980.58	1980.66	1980.71	1980.73	1980.71	1980.66	1980.58	1980.47	1980.32
Girder 2	1980.40	1980.54	1980.65	1980.74	1980.78	1980.80	1980.78	1980.74	1980.65	1980.54	1980.40
Girder 3	1980.32	1980.47	1980.58	1980.66	1980.71	1980.73	1980.71	1980.66	1980.58	1980.47	1980.32

300-46_19.dgn

SGDLI Mod. 04-30-2020

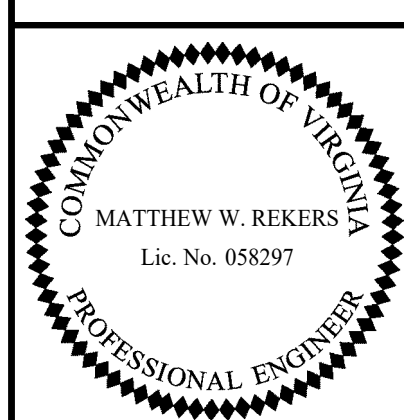

TRANSYSTEMS
 RICHMOND, VA
 STRUCTURAL ENGINEER

COMMONWEALTH OF VIRGINIA DEPARTMENT OF TRANSPORTATION					
STRUCTURE AND BRIDGE DIVISION					
DEAD LOAD DEFLECTIONS AND SLAB ELEVATIONS					
No.	Description	Date	Designed: S.N.....	Date	Plan No.
			Drawn: V.A.U.....	Apr. 2023	300-46
			Checked: M.W.R.....		19 of 42
Revisions					

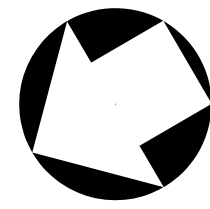

STATE	FEDERAL AID		STATE		SHEET
ROUTE	PROJECT		ROUTE	PROJECT	NO.
VA.			311	0311-080-913, B618	20

Notes:

- Section A-A is perpendicular to end of slab.
- The 1/2" expanded rubber joint filler shall extend the full length of the deck slab extension.
- For spacing of SL0401 and drip detail, see sheet 15.
- For railing details, see sheets 22 and 23.
- For deck slab elevations, see sheet 21.
- Forms for the deck slab extension shall be attached to the girders only; the forms shall not be attached or blocked against the abutment stem or ground. The backwall and forms must be free to move in relation to the abutment.
- 1" preformed joint filler and 1/2" expanded rubber joint filler costs to be included in bid item for Class A3 Concrete.
- A color coating of Dark Gray No. 595-36492 shall be applied to the outside fascia of the deck at both overhangs.

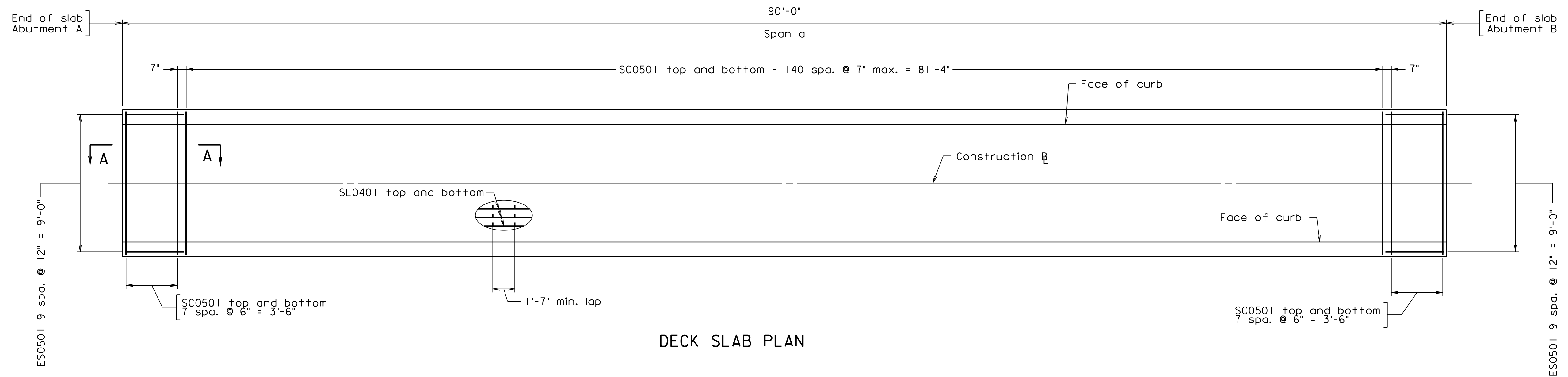

DECK SLAB PLAN

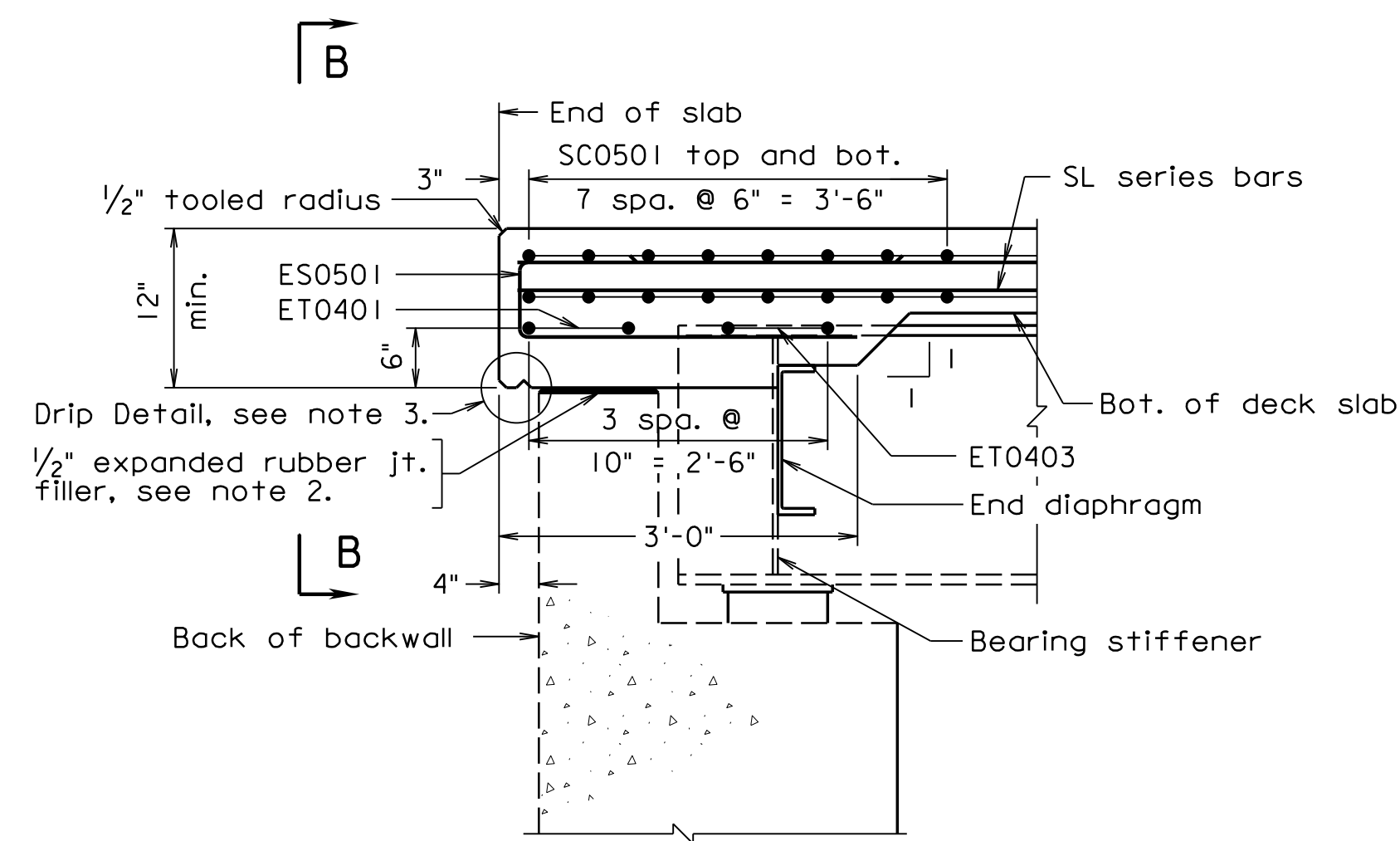

SECTION A-A
SC0502 bars not shown for clarity

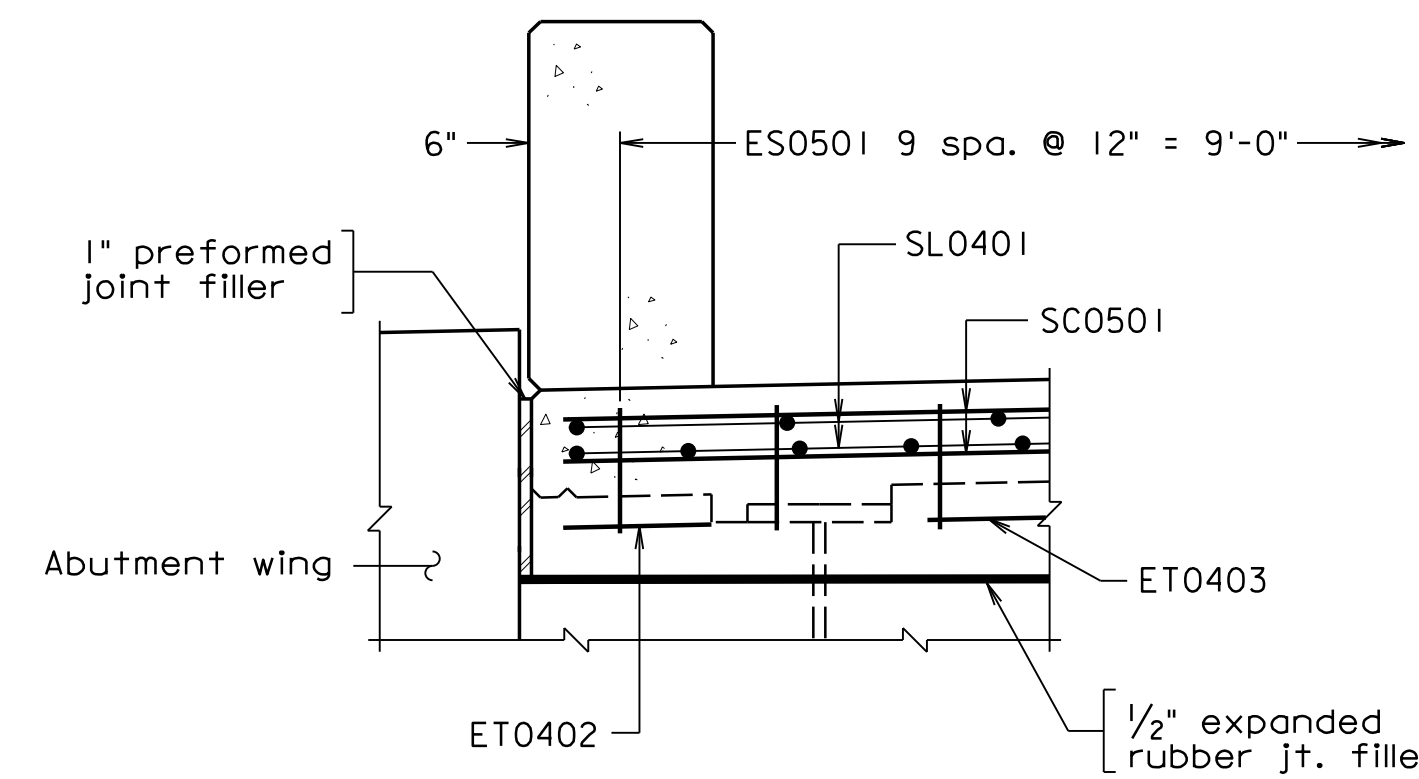

VIEW B-B
Not to scale

Scale: 1/4" = 1'-0"

© 2023, Commonwealth of Virginia

300-46_20.dgn

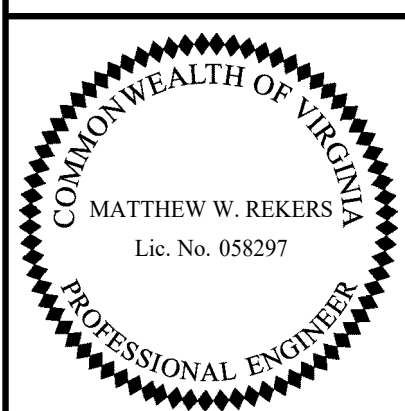

TRANSYSTEMS
RICHMOND, VA
STRUCTURAL ENGINEER

COMMONWEALTH OF VIRGINIA DEPARTMENT OF TRANSPORTATION					
STRUCTURE AND BRIDGE DIVISION					
DECK SLAB PLAN					
No.	Description	Date	Designed: S.N.....	Date	Plan No.
			Drawn: V.A.U.....	Apr. 2023	300-46
			Checked: M.W.R.....		20 of 42
Revisions					

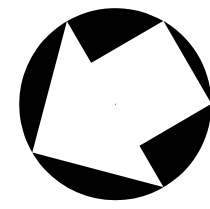

STATE	FEDERAL AID		STATE	SHEET
ROUTE	PROJECT		ROUTE	PROJECT
VA.			311	0311-080-913, B618
				21

Notes:

Slab elevations as shown are on top of finished roadway at face of rails. Those shown on Construction \mathbb{E} are at point of finished grade denoted on Transverse Section.

Points along Construction \mathbb{E} and face of curbs are at 10th points. Straight line interpolations for intermediate elevations on top of finished roadway may be made, in any direction, between any two adjacent points located opposite centerline stations at not more than 9.5 foot intervals.

For parapet details, see sheets 22 and 23.

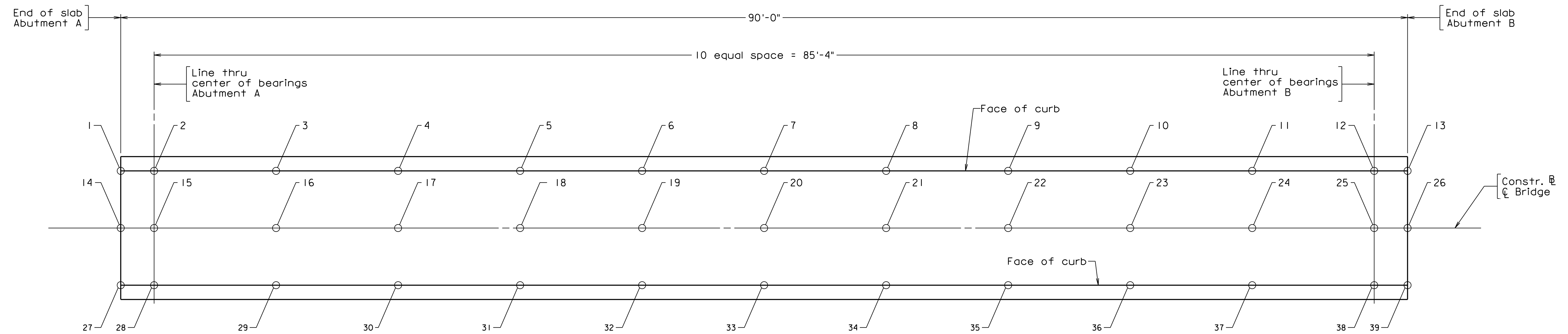

DECK SLAB ELEVATIONS

DECK SLAB ELEVATIONS					
East side		Point of Finished Grade		West side	
Face of curb		Construction \mathbb{E}		Face of curb	
Point	Elevation	Point	Elevation	Point	Elevation
1	1980.27	14	1980.35	27	1980.27
2	1980.32	15	1980.40	28	1980.32
3	1980.46	16	1980.54	29	1980.46
4	1980.57	17	1980.65	30	1980.57
5	1980.66	18	1980.74	31	1980.66
6	1980.70	19	1980.78	32	1980.70
7	1980.72	20	1980.80	33	1980.72
8	1980.70	21	1980.78	34	1980.70
9	1980.66	22	1980.74	35	1980.66
10	1980.57	23	1980.65	36	1980.57
11	1980.46	24	1980.54	37	1980.46
12	1980.32	25	1980.40	38	1980.32
13	1980.27	26	1980.35	39	1980.27

300-46_21.dgn

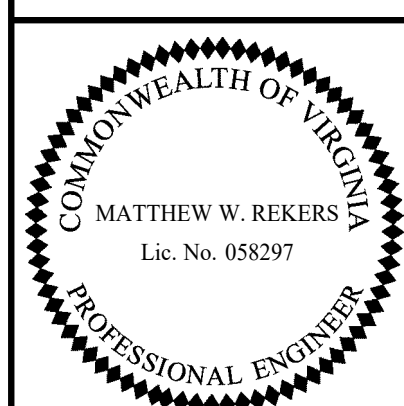

TRANSYSTEMS
RICHMOND, VA
STRUCTURAL ENGINEER

COMMONWEALTH OF VIRGINIA DEPARTMENT OF TRANSPORTATION					
STRUCTURE AND BRIDGE DIVISION					
DECK SLAB ELEVATIONS					
No.	Description	Date	Designed: S.N.....	Date	Plan No.
			Drawn: V.A.U.....	Apr. 2023	300-46
			Checked: M.W.R.....		21 of 42
Revisions					

Scale: 1/4" = 1'-0"

© 2023, Commonwealth of Virginia

STATE	FEDERAL AID		STATE		SHEET
ROUTE	PROJECT		ROUTE	PROJECT	NO.
VA.			311	0311-080-913, B618	22

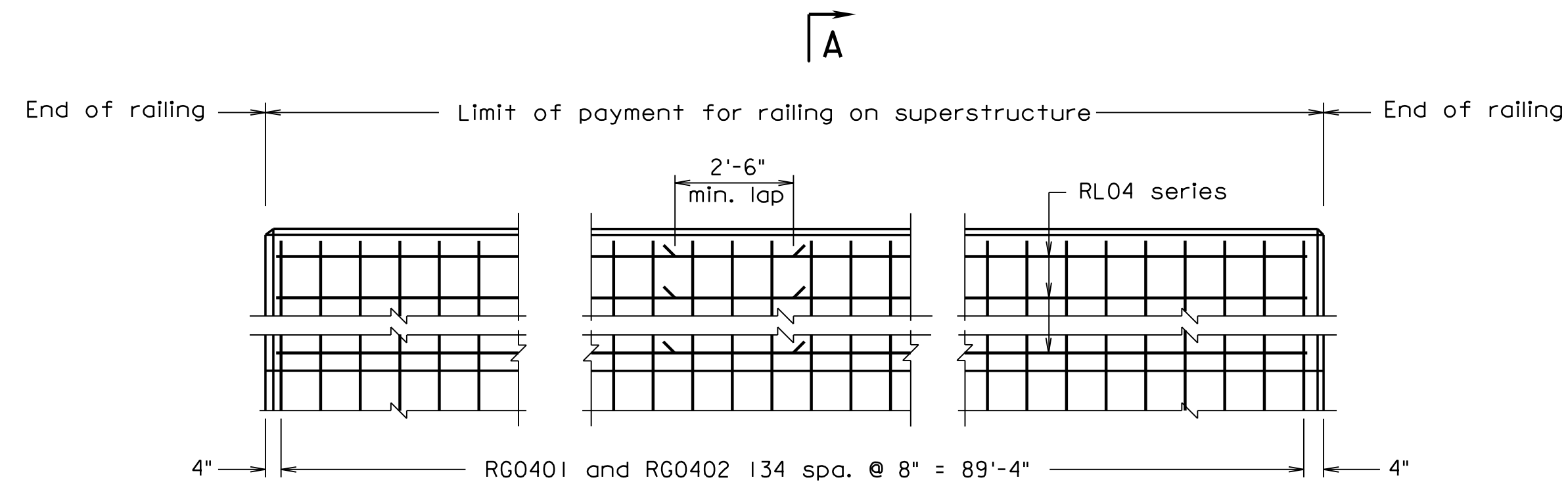

ELEVATION

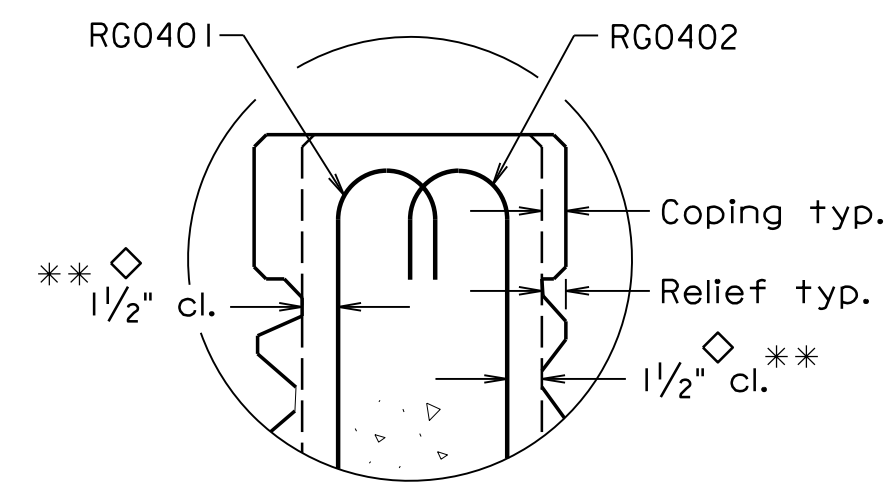

DETAIL A

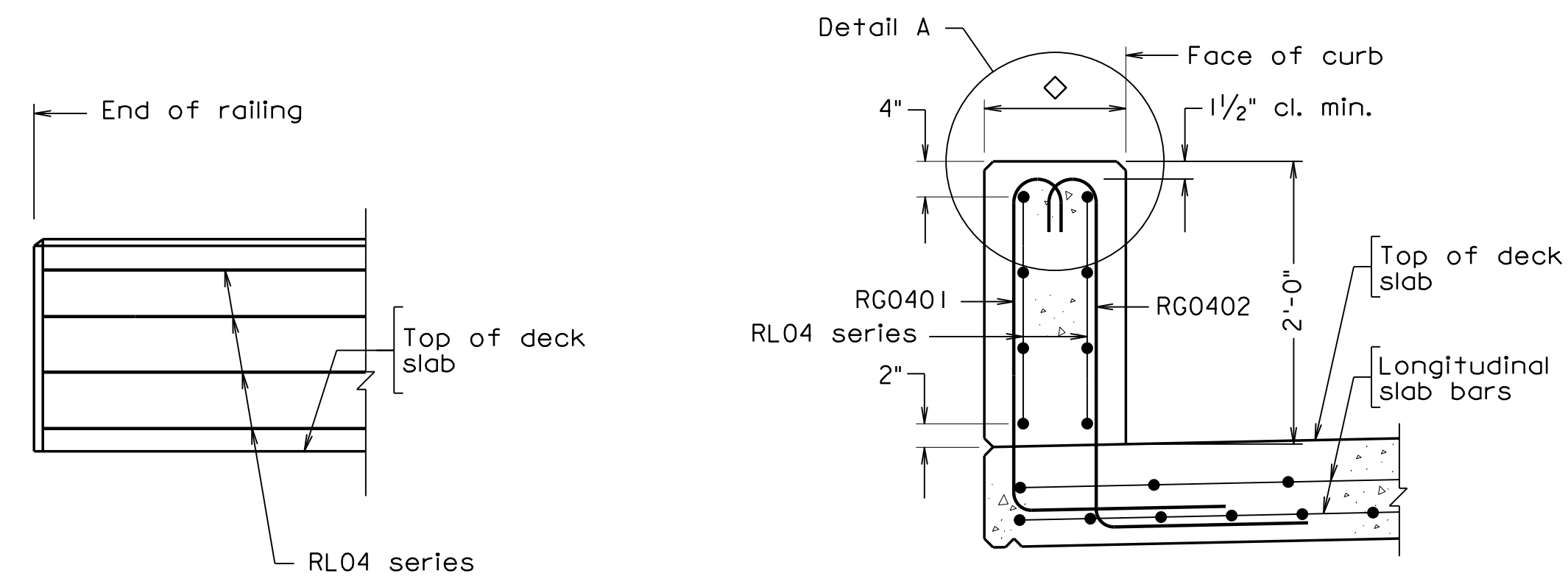

PART ELEVATION

SECTION A-A

Scale: 1" = 1'-0"
Transverse rebars in deck slab not shown for clarity

◇ For dimensions and architectural treatment details, see sheet 23. For minimum cover, see Detail A.

** The cover tolerance referenced in the VDOT Road and Bridge Specifications as -0" to +1/2" is shifted to -1/4" to +1/4" for placement of the RG04 series bars.

Notes:

Plan dimensions shown are measured in the respective horizontal and vertical planes.

The Contractor shall determine all dimensions and details necessary for installation.

All concrete shall be Low Shrinkage Class A4 Modified.

All levels for concrete shall be 3/4".

All reinforcing steel shall be Corrosion Resistant Reinforcing Steel, Class I.

Bid price for architectural treatment includes concrete in relief and coping.

The sign shall be placed on the barrier wall between the fence posts. The sign shall be centered on the bridge.

Threaded inserts, when embedded as shown, shall develop full strength of threaded bolts. Embedment of insert per manufacturer's recommendations or 5" whichever is greater.

Bolts excluding threads, shall have the same vinyl coating. Threaded inserts shall not be vinyl coated.

Threaded inserts and bolt threads shall not be galvanized or coated.

Washers, nuts and bolts shall be painted brown to match the color of the sign.

REINFORCING STEEL SCHEDULE

Mark	Size	No.	Length	Pin ϕ	Location
RG0401	#4	270	4'-2 1/2"	3"	Parapet
RG0402	#4	270	4'-3 1/2"	3"	Parapet
RL04	#4	32	46'-6"	—	Parapet

Dimensions in bending diagram are out-to-out of bars.

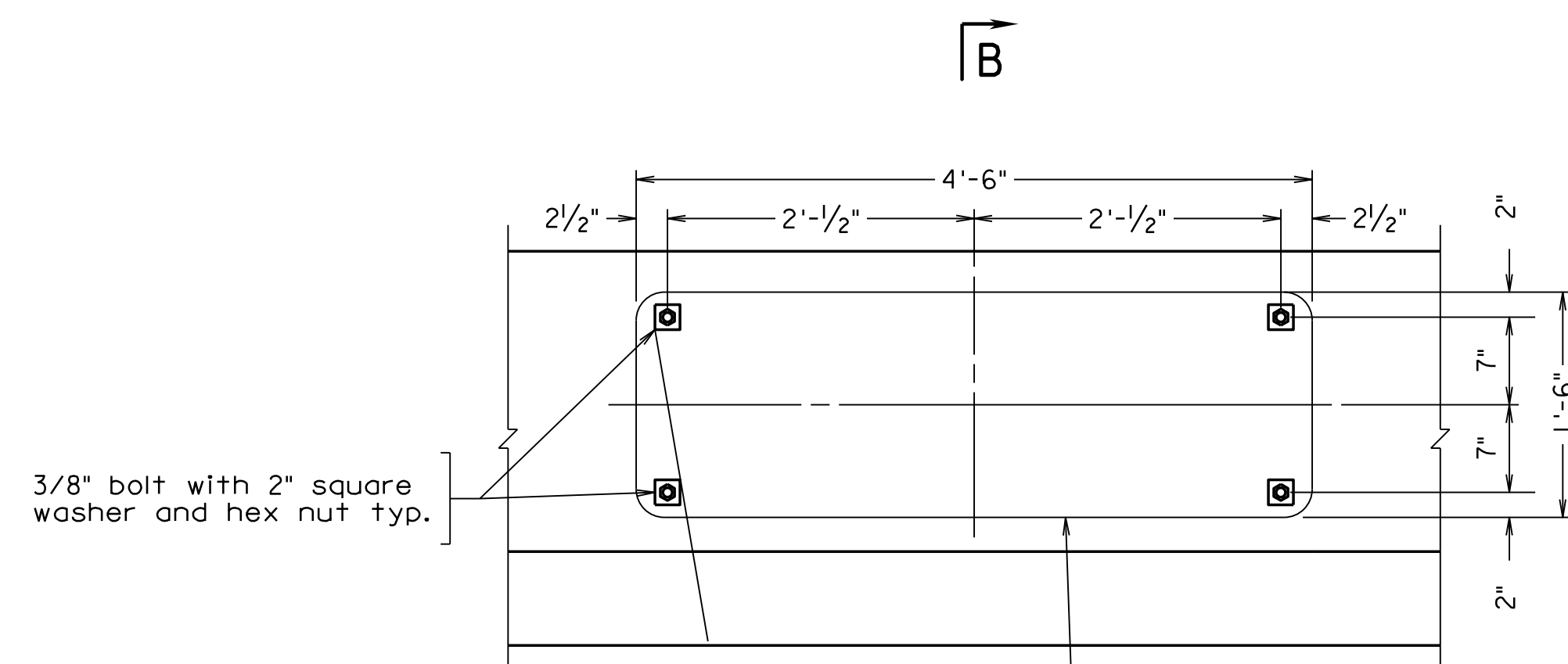

SIGN ATTACHMENT ELEVATION

Scale: 1" = 1'-0"

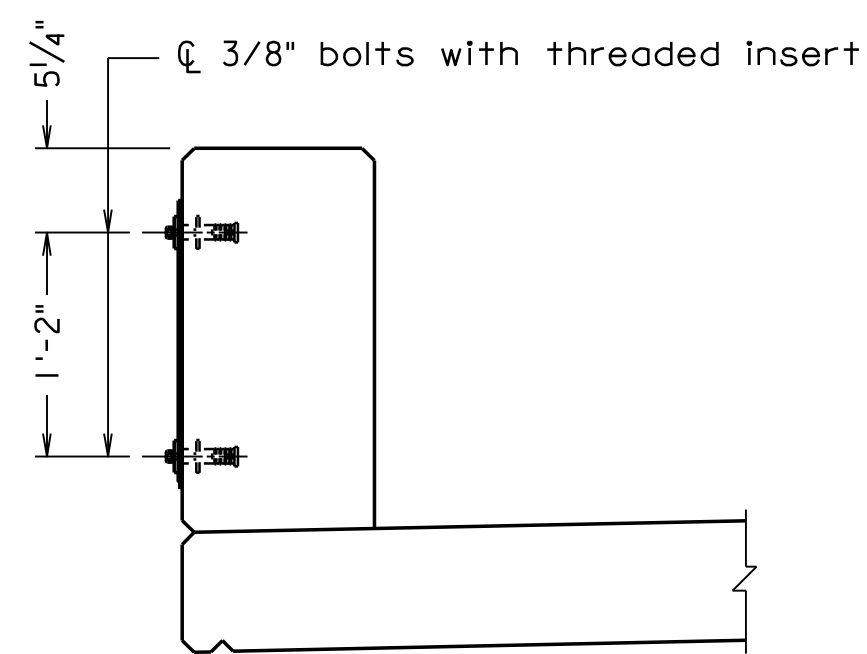

SECTION B-B

Scale: 1" = 1'-0"

Scale: 3/4" = 1'-0" unless otherwise noted.

© 2023, Commonwealth of Virginia

COMMONWEALTH OF VIRGINIA DEPARTMENT OF TRANSPORTATION					
STRUCTURE AND BRIDGE DIVISION					
PARAPET DETAILS (1 OF 2)					
No.	Description	Date	Designed: S.N.....	Date	Plan No.
			Drawn: V.A.U.....	Apr. 2023	300-46
			Checked: M.W.B.....		22 of 42

300-46-22.dgn

10-31-2022

CPSR-1-AT Mod.

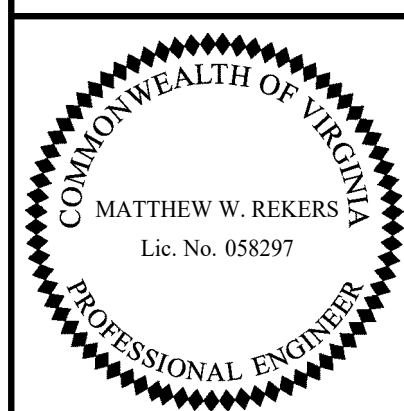

TRANSYSTEMS
RICHMOND, VA
STRUCTURAL ENGINEER

STATE	FEDERAL AID	STATE	SHEET
ROUTE	PROJECT	ROUTE	NO.
VA.		311	24
		0311-080-913, B618	

Notes:

The fence to be used on this project shall be Type C as shown in Typical Section.

Posts shall be set vertical. Rails shall be set parallel to the top of base of railing.

Posts shall be equally spaced, not to exceed 10'-0". Posts shall be placed a minimum of 4'-0" from centerline of mounted sign.

Chain link fabric shall be placed on inside of posts and rails.

Chain link fabric, posts, rails and other associated hardware shall be brown similar to Federal Standard Color No. 595-20059 and vinyl coated steel.

Ends of wire ties shall be turned to outside of fence to prevent injury to pedestrians.

Threaded inserts, when embedded as shown, shall develop full strength of threaded bolts. Embedment of insert per manufacturers recommendations or 5" whichever is greater.

Bolts and washers in the Mechanical Lug Detail shall be ASTM A276, Type 304 Stainless Steel. All other bolts shall be high strength, ASTM F3125 Grade A325, Type I.

All posts and rails shall be welded or seamless steel galvanized pipe conforming to ASTM F1083, Schedule 40.

Fence framing (posts and railing) shall be grounded in accordance with Section 507.

Bolts excluding threads, shall have the same vinyl coating. Threaded inserts shall not be vinyl coated.

Threaded inserts and bolt threads shall not be galvanized or coated.

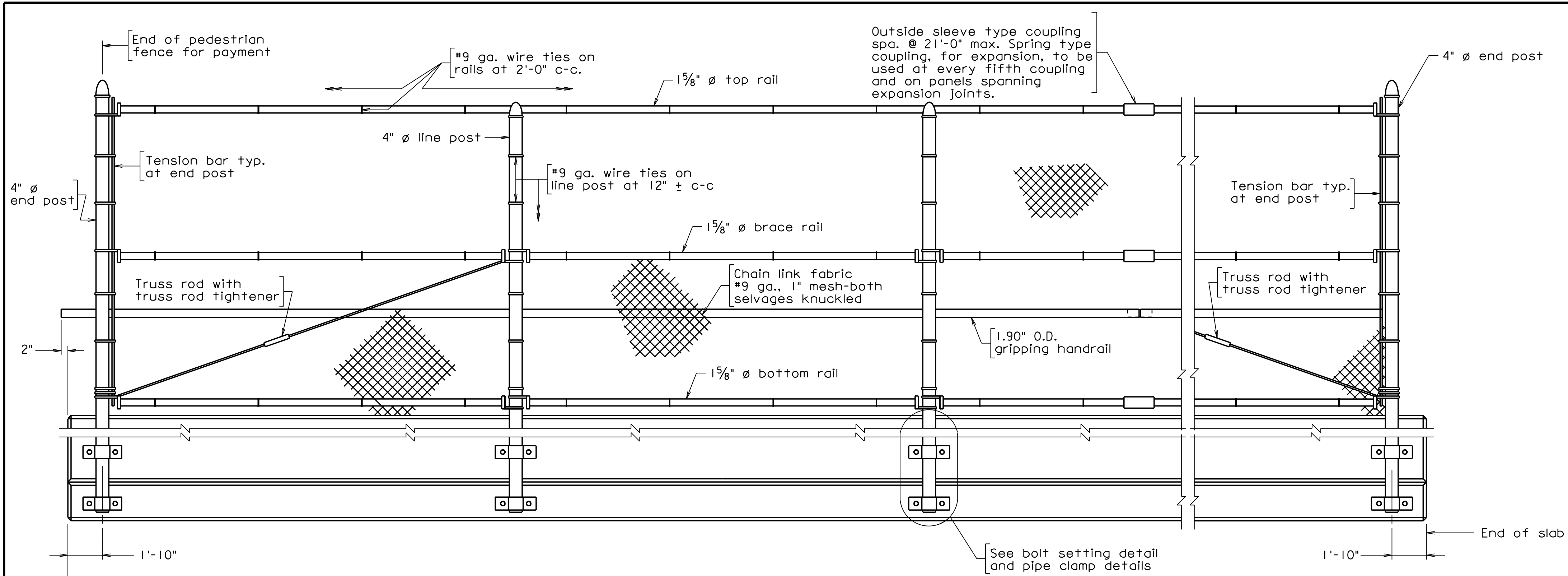

ELEVATION
Not to scale
Architectural treatment not shown for clarity

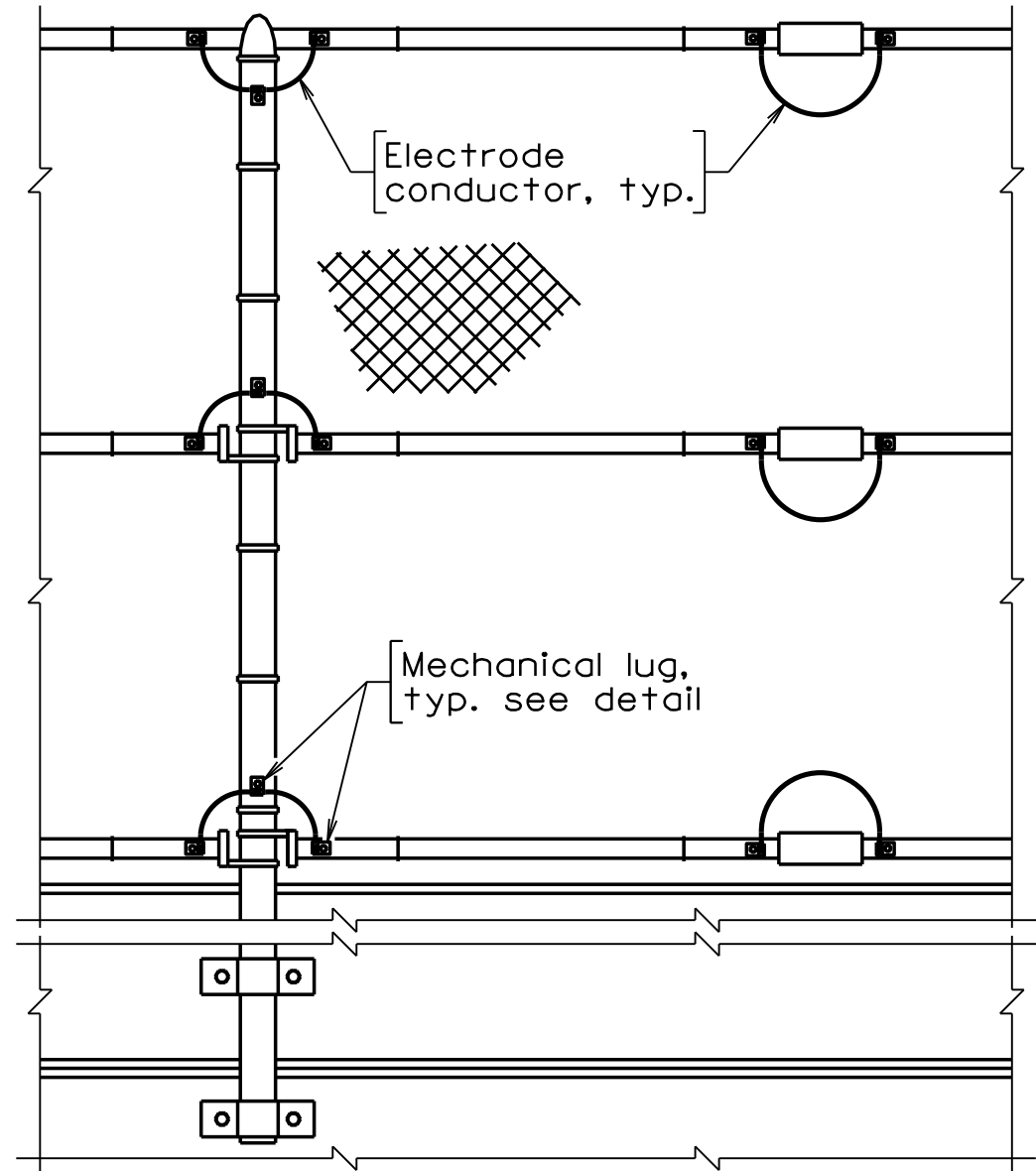

ELECTRICAL CONTINUITY
FOR VINYL COATED STEEL PEDESTRIAN FENCE
(Installed on the non-traffic side of the fence)
Not to scale

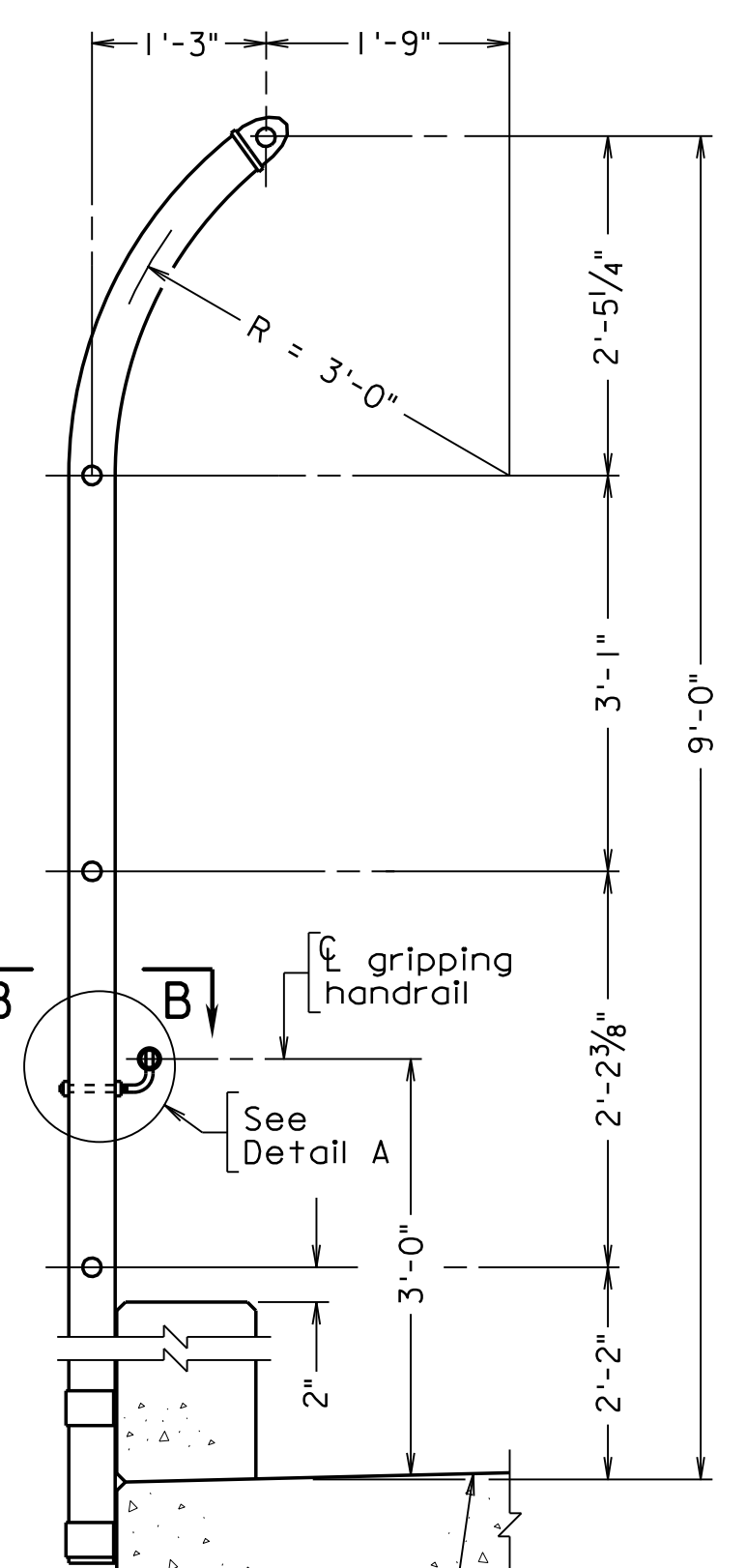

TYPE C TYPICAL SECTION
Scale: 3/4" = 1'-0"

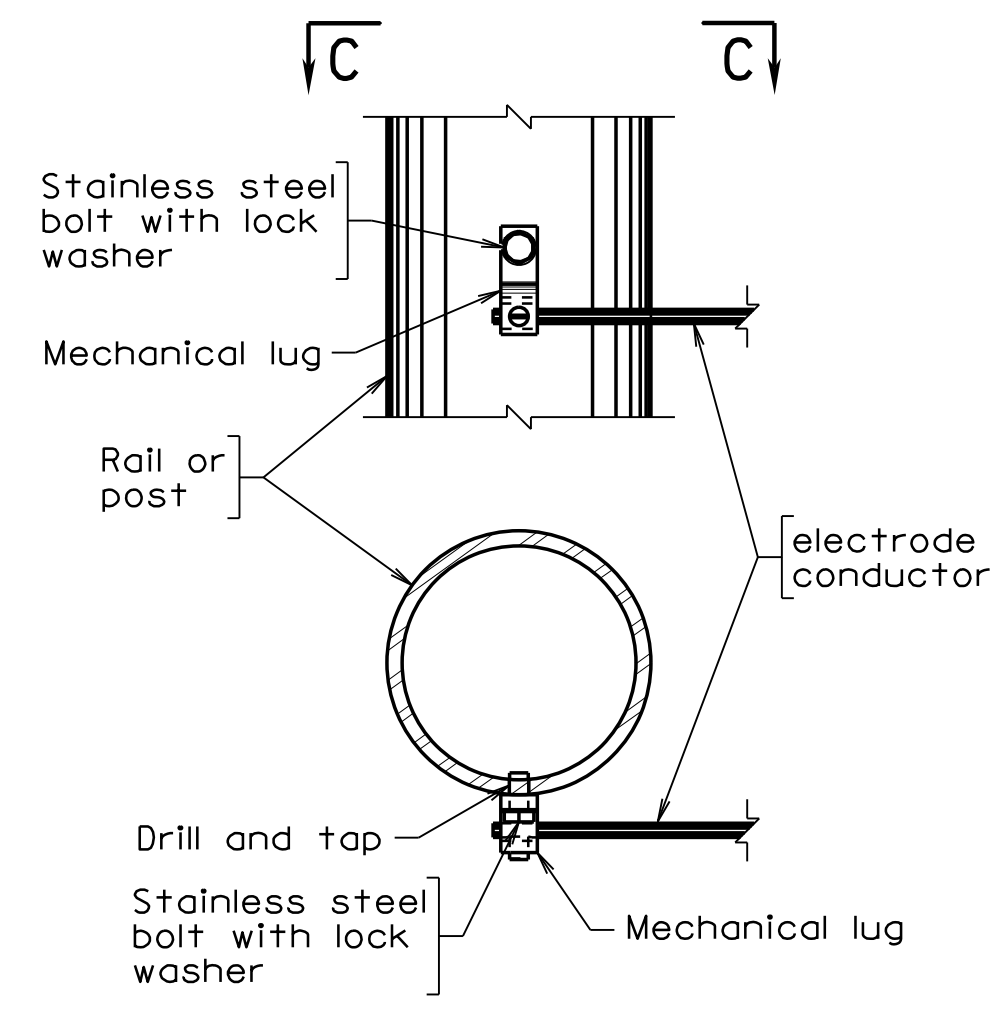

SECTION C-C MECHANICAL LUG DETAIL
Not to scale

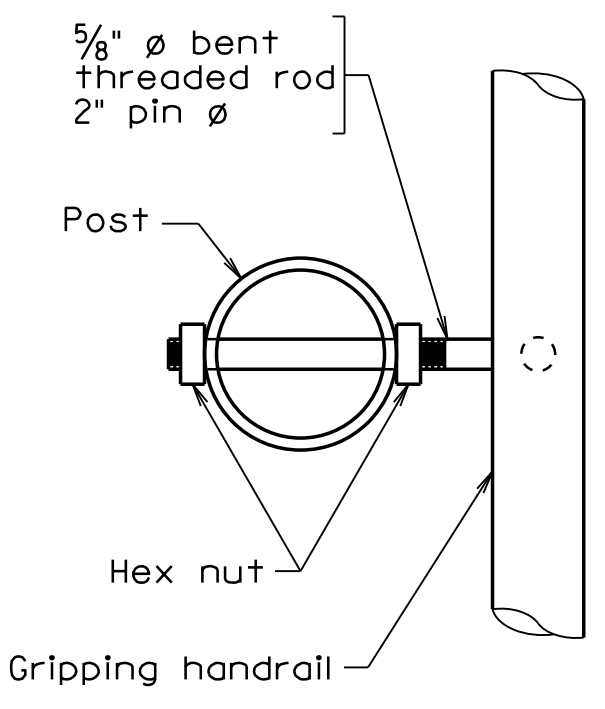

SECTION B-B
Scale: 3" = 1'-0"

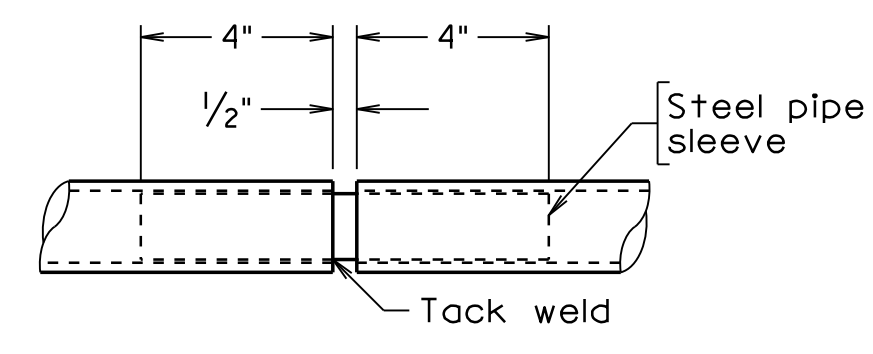

TYPICAL EXPANSION JOINT DETAIL HANDRAIL
Scale: 3" = 1'-0"
Handrail horizontal expansion joint shall be provided at the middle of every 3rd panel and on panels spanning expansion joints.

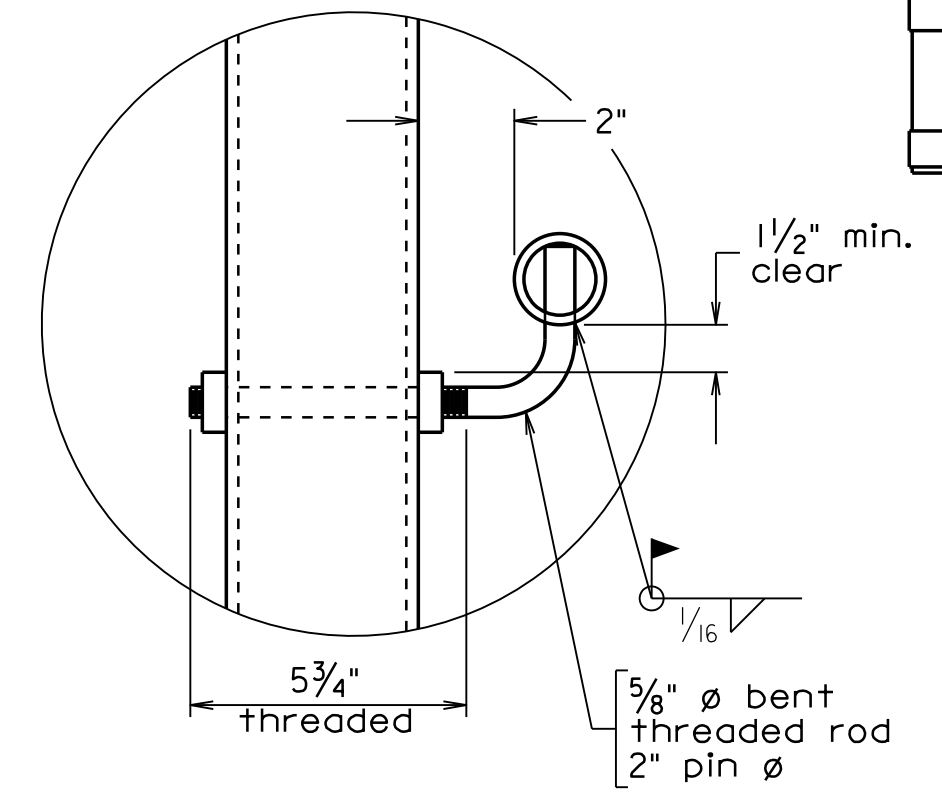

DETAIL A
Scale: 3" = 1'-0"

Scale as noted. © 2023, Commonwealth of Virginia

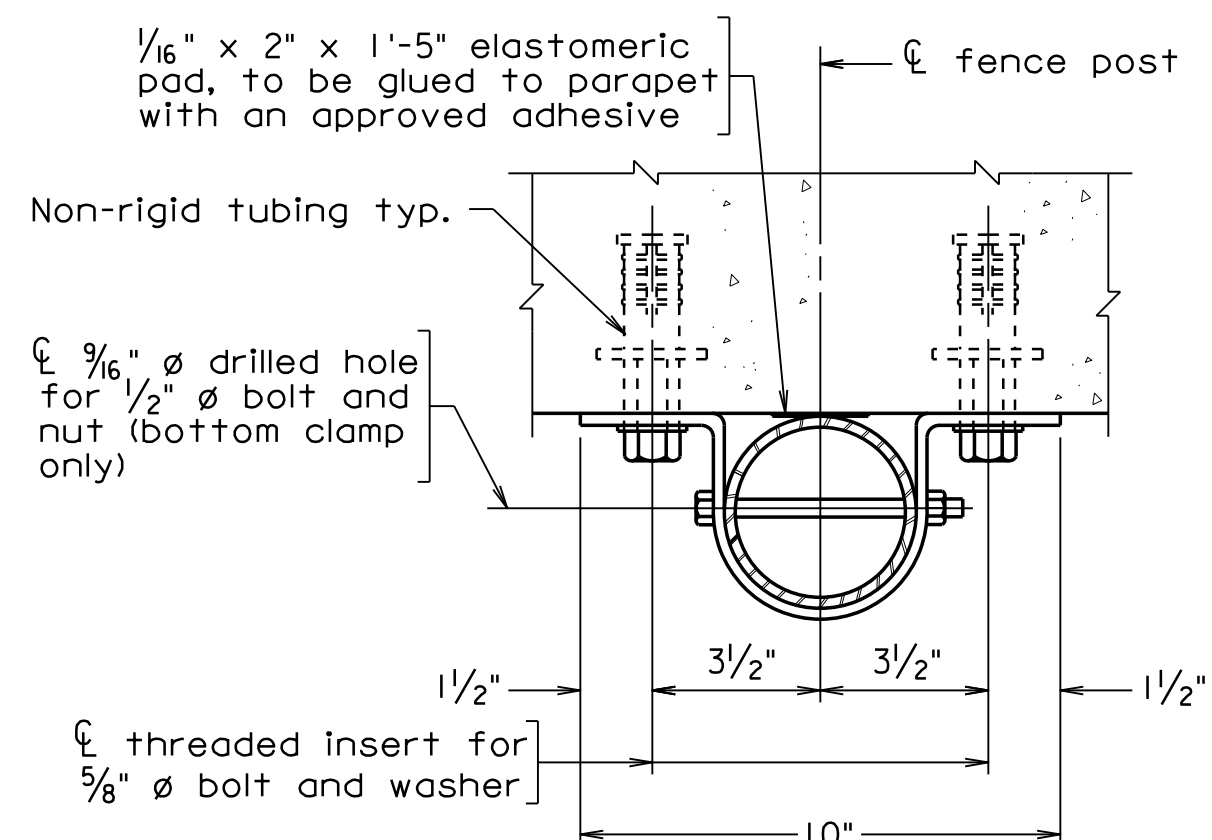

PLAN
Scale: 3" = 1'-0"

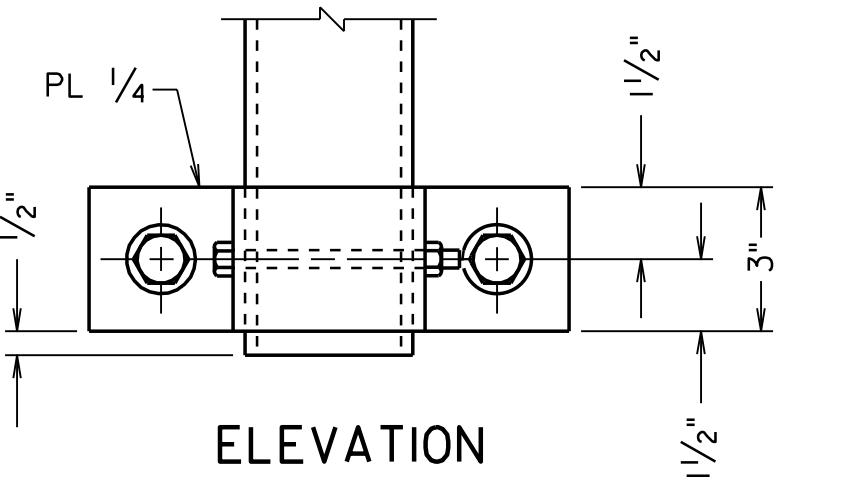

ELEVATION PIPE CLAMP DETAILS
Scale: 3" = 1'-0"

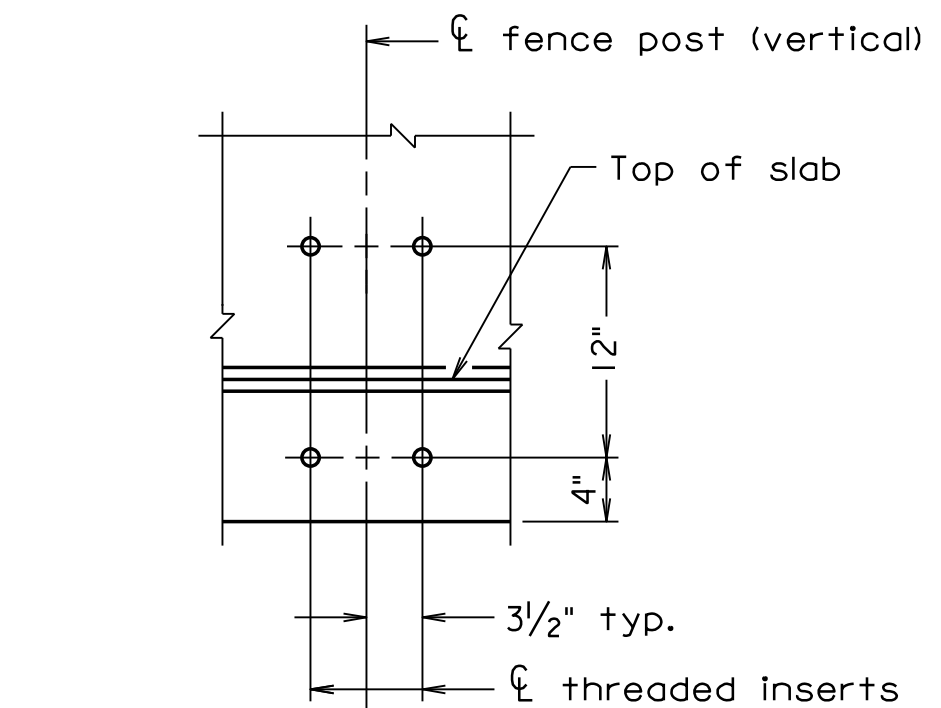

BOLT SETTING DETAIL
Scale: 1" = 1'-0"

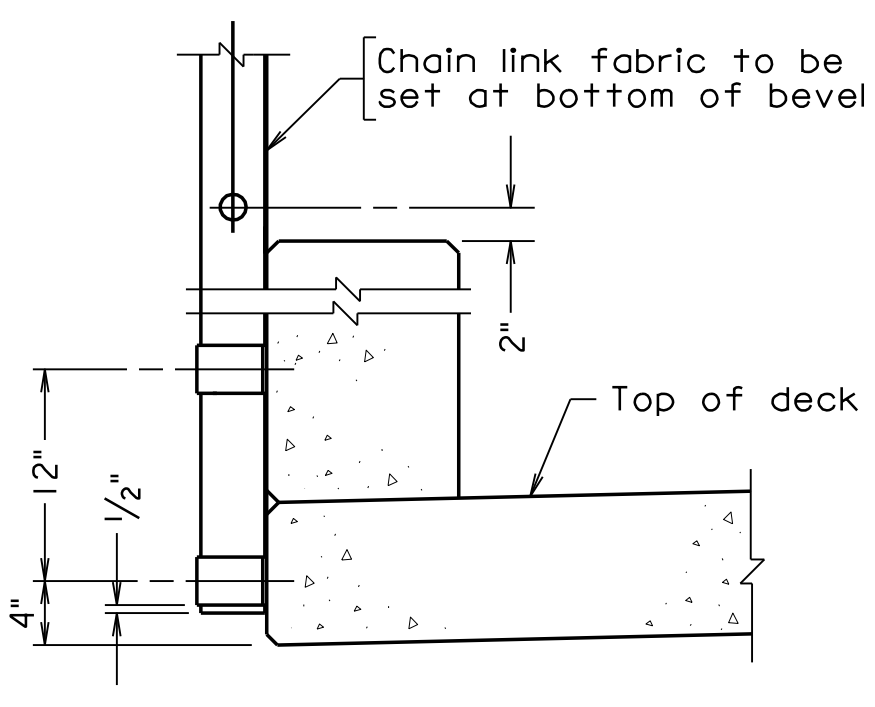

TYPICAL PART SECTION
Scale: 1" = 1'-0"

300-46.24.dgn

BPF-4 Mod. 04-30-2021

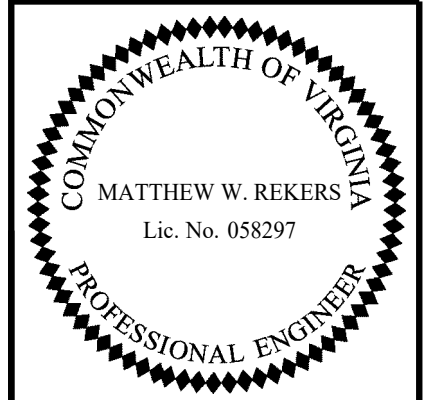

TRANSYSTEMS
RICHMOND, VA
STRUCTURAL ENGINEER

Sealed and Signed by:
Junyi Meng
Lic. No. 033572
On the date of
April 31, 2021

A copy of the original sealed and signed standard drawing is on file in the Central Office.

VDOT S&B DIVISION
RICHMOND, VA
STRUCTURAL ENGINEER

COMMONWEALTH OF VIRGINIA DEPARTMENT OF TRANSPORTATION STRUCTURE AND BRIDGE DIVISION			
PEDESTRIAN FENCE DETAILS			
No.	Description	Date	Revisions
Designed: S.N.	Date	Plan No.	Sheet No.
Drawn: V.A.U.	Apr. 2023	300-46	24 of 42
Checked: M.W.R.			

STATE	FEDERAL AID	STATE	SHEET
ROUTE	PROJECT	ROUTE	NO.
VA.		311	25
		0311-080-913, B618	

REINFORCING STEEL SCHEDULE							DIMENSION TABLE															
MARK	NO.	BAR SIZE	PIN DIA. FT-IN	LENGTH		WEIGHT (LBS.)	LOCATION	TYPE	A	B	C	D	E	F	G	H	I	J	K	L	V	N
				FT-IN	FT-IN				FT-IN	FT-IN	FT-IN	FT-IN	FT-IN	FT-IN	FT-IN	FT-IN	FT-IN	FT-IN	FT-IN	FT-IN	FT-IN	FT-IN
AF0602	78	6		ABUTMENT A 13-08		1601	FOOTING / RET. WALL	I	13-08													
AF0603	30	6		9-00		406	FOOTING	I	9-00													
AF0605	30	6		28-03		1273	RET. WALL	I	28-03													
TOTAL	WEIGHT IN	PRECEDING GROUP OF BARS				3280																
AC0401	399	4	3	2-04		611	COPING	7	9-03	4	1-01	1-01										
AC0402	4	4		9-03		25	COPING	I	9-03													
AC0403	1	4		12-09		9	COPING	I	12-09													
AC0404	2	4		2-06		3	COPING	I	2-06													
AC0405	2	4		4-04		6	COPING	I	4-04													
AC0406	2	4		5-01		7	COPING	I	5-01													
AC0407	4	4		13-07		36	COPING	I	13-07													
AC0408	2	4		1-00		1	COPING	I	1-00													
AC0409	2	4		14-01		19	COPING	I	14-01													
AC0410	2	4		3-02		4	COPING	I	3-02													
AC0411	2	4		12-03		16	COPING	I	12-03													
AC0412	2	4		1-09		2	COPING	I	1-08													
AF0601	106	6	4 1/2	7-06		1182	FOOTING / RET. WALL	43	1-00	6-07												
AF0804	128	8	6	8-08		2948	FOOTING / RET. WALL	43	1-04	7-06												
AF0606	32	6	4 1/2	5-04	TO 8-00	317	RET. WALL	43	1-00	VARY												
AH0601	33	6		12-06		620	STEM / BACK WALL	I	12-06													
AH0502	8	5		28-06		237	RET. WALL	I	28-05													
AH0503	28	5		17-05	TO 27-05	655	RET. WALL	I	VARY													
AH0504	24	5		2-05	TO 12-05	186	RET. WALL	I	VARY													
AL0501	4	5	3 3/4	15-03		63	RET. WALL	2	14-05	4 1/4	8 1/2	9 1/4										
AL0502	4	5	3 3/4	15-09		66	RET. WALL	2	12-10	1-03 5/8	2-07 3/8	2-10 3/4										
AS0401	80	4		1-10		98	WEEPHOLES	I	1-10													
AV0401	25	4	3	12-09		213	STEM	30	2-07	6 1/2	9-09	5-00										
AV0402	25	4	3	18-04		305	STEM / BACK WALL	7														
AV0403	8	4		9-09		52	STEM	I	9-09													
AV0804	8	8		13-10		295	RET. WALL	I	13-10													
AV0805	100	8		7-08	TO 13-08	2848	RET. WALL	I	VARY													
AV0606	16	6		7-04		176	RET. WALL	I	7-04													
AV0607	32	6		4-08		288	RET. WALL	I	VARY													
AW0501	4	5	2 1/2	3-09	TO 7-04	16	WING HAUNCH	51	1-00	8												
AW0602	8	6		6-03		75	WING HAUNCH	I	6-03													
AW0803	20	8		13-10		739	WING WALL	I	13-10	7-00	3-02											
AW0604	76	6	4 1/2	10-01		1143	WING WALL	6														
AW0505	20	5		5-01		106	WING WALL	I	5-01	4-00	4-00											
AW0606	38	6	4 1/2	7-11		448	WING WALL	6														
TOTAL	WEIGHT IN	PRECEDING GROUP OF BARS				13813																

DIMENSION VARIATION TABLE									
MARK	NO. EA.	DIMEN- SION	FROM FT-IN	TO FT-IN	VARY BY FT-IN	DIMEN- SION	FROM FT-IN	TO FT-IN	VARY BY FT-IN
AF0606	4	C	4-05	7-01	4 5/8				
AH0503	4	A	17-05	27-05	1-08				
AH0504	4	A	2-05	12-05	2-00				
AV0805	4	A	7-08	13-08	3				
AV0607	4	A	4-08	7-04	4 5/8				

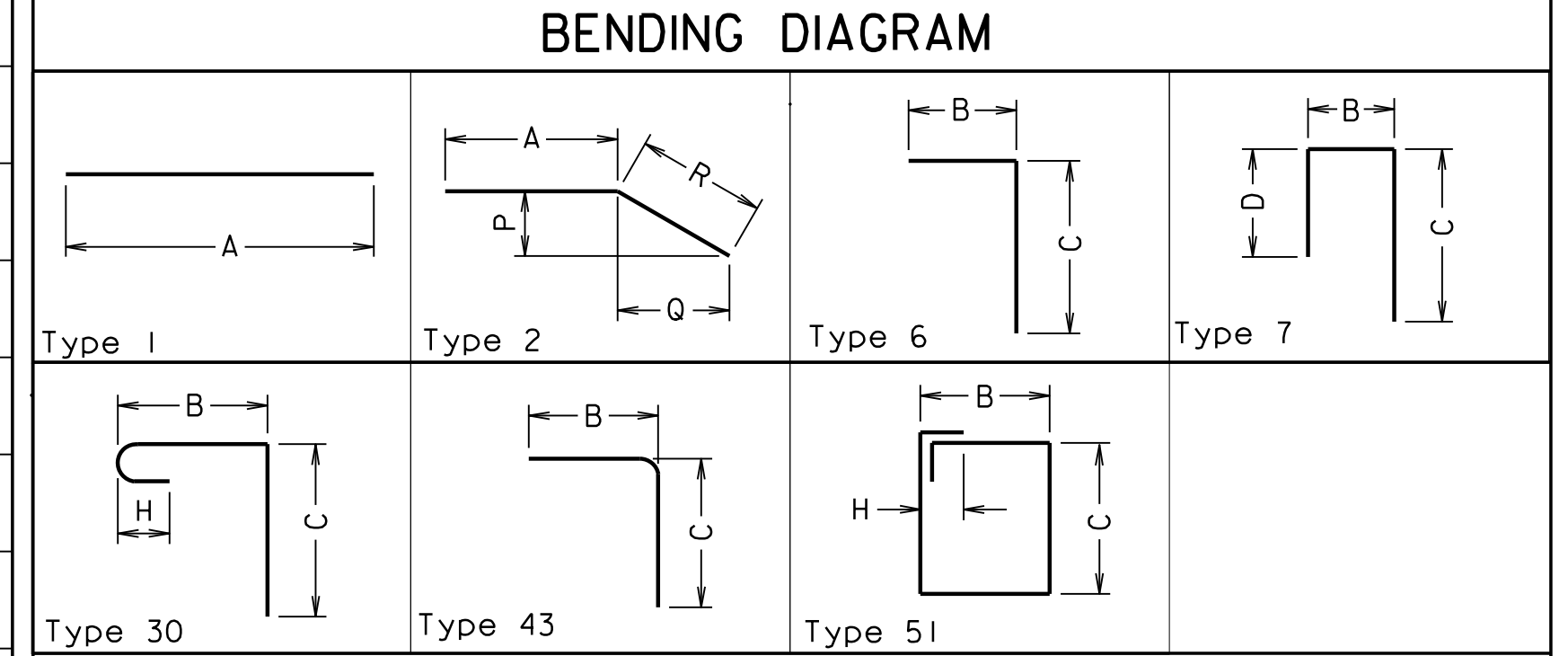

300-46_25.dgn

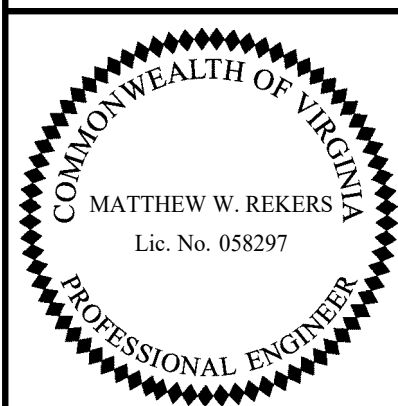

NOTES:

Dimensions in Bending Diagram are out-to-out of bars.

Weights in schedule are based on density of 490 lb/ft³.

If fabrication of deck slab bar is not possible for length detailed and multiple bars are required, bars shall have the least number of Class B splices possible. Splices shall be located approximately at points of contraflexure and splices in alternate bars shall be located in different bays.

Straight bars (top and bottom) may be substituted for truss bars (SB series) in the deck superstructure at no extra cost to the Department.

TRANSYSTEMS
RICHMOND, VA
STRUCTURAL ENGINEER

COMMONWEALTH OF VIRGINIA DEPARTMENT OF TRANSPORTATION STRUCTURE AND BRIDGE DIVISION					
ABUTMENT A REINFORCING STEEL SCHEDULE					
No.	Description	Date	Designed: S.N.	Date	Plan No.
			Drawn: V.A.U.	Apr. 2023	300-46
			Checked: M.W.R.		25 of 42
Revisions					

STATE	FEDERAL AID		STATE	SHEET
ROUTE	PROJECT		ROUTE	NO.
VA.			311	26
			0311-080-913, B618	

REINFORCING STEEL SCHEDULE							DIMENSION TABLE																
MARK	NO.	BAR SIZE	PIN DIA. FT-IN	LENGTH		WEIGHT (LBS.)	LOCATION	TYPE	A	B	C	D	E	F	G	H	I	J	K	L	V	N	
				FT-IN	FT-IN				FT-IN	FT-IN	FT-IN	FT-IN	FT-IN	FT-IN	FT-IN	FT-IN	FT-IN	FT-IN	FT-IN	FT-IN	FT-IN	FT-IN	FT-IN
ABUTMENT B																							
AF0602	18	6		23-04		631	FOOTING	1	23-04														
AF0603	48	6		8-00		577	FOOTING	1	8-00														
AF0605	28	6		16-10	1/2 TO 25-02 1/2	885	RET. WALL FOOTING	1	VARY														
AF0606	2	6		24-06		74	RET. WALL FOOTING	1	24-06														
AF0607	2	6		22-11		69	RET. WALL FOOTING	1	22-11														
AF0608	2	6		22-00		66	RET. WALL FOOTING	1	22-00														
AF0609	2	6		2-02		7	RET. WALL FOOTING	1	2-02														
AF0610	2	6		3-08		11	RET. WALL FOOTING	1	3-08														
AF0611	26	6		15-09		615	RET. WALL FOOTING	1	15-09														
AF0612	2	6		16-03	TO 17-06	152	RET. WALL FOOTING	1	VARY														
AF0613	12	6		9-01	TO 16-11	234	RET. WALL FOOTING	1	VARY														
AF0614	2	6		7-06		23	RET. WALL FOOTING	1	7-06														
AF0615	2	6		5-03		16	RET. WALL FOOTING	1	5-03														
AF0616	2	6		3-01		9	RET. WALL FOOTING	1	3-01														
AF0617	2	6		18-06		56	RET. WALL FOOTING	1	18-06														
AF0618	54	6		6-06		527	RET. WALL FOOTING	1	6-06														
AF0619	16	6		25-09		619	RET. WALL FOOTING	1	25-09														
TOTAL WEIGHT IN PRECEDING GROUP OF BARS							4569																
ABUTMENT B CORROSION RESISTANT																							
AC0401	494	4	3	2-04		756	COPING	7		4	1-01	1-01											
AC0402	4	4		9-02		24	COPING	1	9-02														
AC0403	1	4		11-08		8	COPING	1	11-08														
AC0404	2	4		2-06		3	COPING	1	2-06														
AC0405	1	4		3-10		3	COPING	1	3-10														
AC0406	2	4		4-01		5	COPING	1	4-01														
AC0407	2	4		13-05		18	COPING	1	13-05														
AC0408	1	4		4-04		3	COPING	1	4-04														
AC0409	1	4		13-11		9	COPING	1	13-11														
AC0410	1	4		2-08		2	COPING	1	2-08														
AC0411	1	4		11-03		8	COPING	1	11-03														
AC0412	1	4		8-03		6	COPING	1	8-03														
AC0413	1	4		13-00		9	COPING	1	13-00														
AC0414	1	4		7-08		5	COPING	1	7-08														
AC0415	1	4		7-10		5	COPING	1	7-10														
AC0416	1	4		13-03		9	COPING	1	13-03														
AC0417	1	4		21-09		19	COPING	1	21-09														
AC0418	1	4		3-06		2	COPING	1	3-06														
AC0419	1	4		11-03		8	COPING	1	11-03														
AC0420	1	4		12-09		9	COPING	1	12-09														
AF0601	124	6	4 1/2	7-06		1383	FOOTING / RW FOOTING	43		1-00	6-07												
AF0804	174	8	6	9-08		4471	FOOTING / RW FOOTING	43		1-04	8-06												
AF0620	32	6	4 1/2	7-01		339	PILASTER	43		1-00	6-02 1/2												
AF0621	8	6	4 1/2	6-07		79	STAIR FOOTING	43		1-00	5-08 1/2												
AF0422	40	4	2	2-04		62	PILASTER	51		6	6				4 1/2								
AF0423	8	4	2	3-04		18	STAIR FOOTING	51		9	9				4 1/2								
AH0601	33	6		11-08		578	STEM / BACKWALL	1	11-08														
AH0502	2	5	3 3/4	4-04		9	RET. WALL	2	3-00			8 3/4	1-01 3/4	1-04									
AH0503	14	5	3 3/4	22-03		325	RET. WALL	2	20-08 1/2			10 1/8	1-03 7/8	1-06 1/2									
AH0504	14	5	3 3/4	21-10		319	RET. WALL	2	20-06 1/8			8 3/4	1-01 3/4	1-04									
AH0505	14	5	3 3/4	16-07		241	RET. WALL	2	12-05 3/8	2-02 1/2	3-05 3/8	4-00 7/8	3-07 1/2	4-03 3/8									
AH0506	14	5	3 3/4	17-00		247	RET. WALL	2	12-07 7/8	2-03 7/8	3-07 1/2	4-00 7/8	3-07 1/2	4-03 3/8									
AH0507	2	5	3 3/4	11-00		23	RET. WALL	1	11-00														
AH0508	24	5	3 3/4	25-10		647	RET. WALL	2	25-10														
AL0501	2	5	3 3/4	18-06		39	RET. WALL	2	11-06 1/2			9 1/4	6-10 3/4	6-11 1/4									
AL0502	2	5	3 3/4	7-04		15	RET. WALL	2	3-00			2-03 7/8	3-07 1/2	4-03 3/8									
AL0503	2	5	3 3/4	10-07		22	RET. WALL	2	3-10														
AL0504	2	5	3 3/4	21-09		45	RET. WALL	2	21-09			4 1/4	6-08 3/4	6-08 7/8									
AS0401	96	4		1-10		118	WEEPHOLES	1	1-10														
AV0401	23	4	3	12-08		194	STEM	30		2-07	9-08												
AV0402	23	4	3	18-02		279	STEM / BACK WALL	7		6 1/2	12-10												
AV0403	8	4		9-08		52	STEM	1	9-08														
AV0804	158	8		13-03		5590	RET. WALL	1	13-03														
AV0605	60	6		11-04	TO 13-01	1100	RET. WALL	1	VARY														
AV0606	10	6		11-04		170	RET. WALL	1	11-04														
AW0501	2	5	2 1/2	3-09		8	WING HAUNCH	51		1-00	8				5 5/8								
AW0602	2	6		6-03		56	WING HAUNCH	1	6-03														
AW0803	16	8		14-00		598	WING WALL	1	14-00														
AW0604	76	6	4 1/2	9-01		1029	WING WALL	6	4-01	6-00	3-02												
AW0505	20	6	4 1/2	4-01		85	WING WALL	1	4-01	4-00	4-00												
AW0606	38	6	4 1/2	7-11		448	WING WALL	6	4-01	4-00	4-00												
TOTAL WEIGHT IN PRECEDING GROUP OF BARS							19493																

DIMENSION VARIATION TABLE									
MARK	NO. EA.	DIMEN- SION	FROM FT-IN	TO FT-IN	VARY BY FT-IN	DIMEN- SION	FROM FT-IN	TO FT-IN	VARY BY FT-IN
AF0605	2	A	16-10 1/2	25-02 1/2	7 3/4				
AF0612	2	A	16-03	17-06	7 1/2				
AF0613	2	A	9-01	16-11	1-06 3/4				
AV0605	2	A	11-04	13-01	0 3/4				

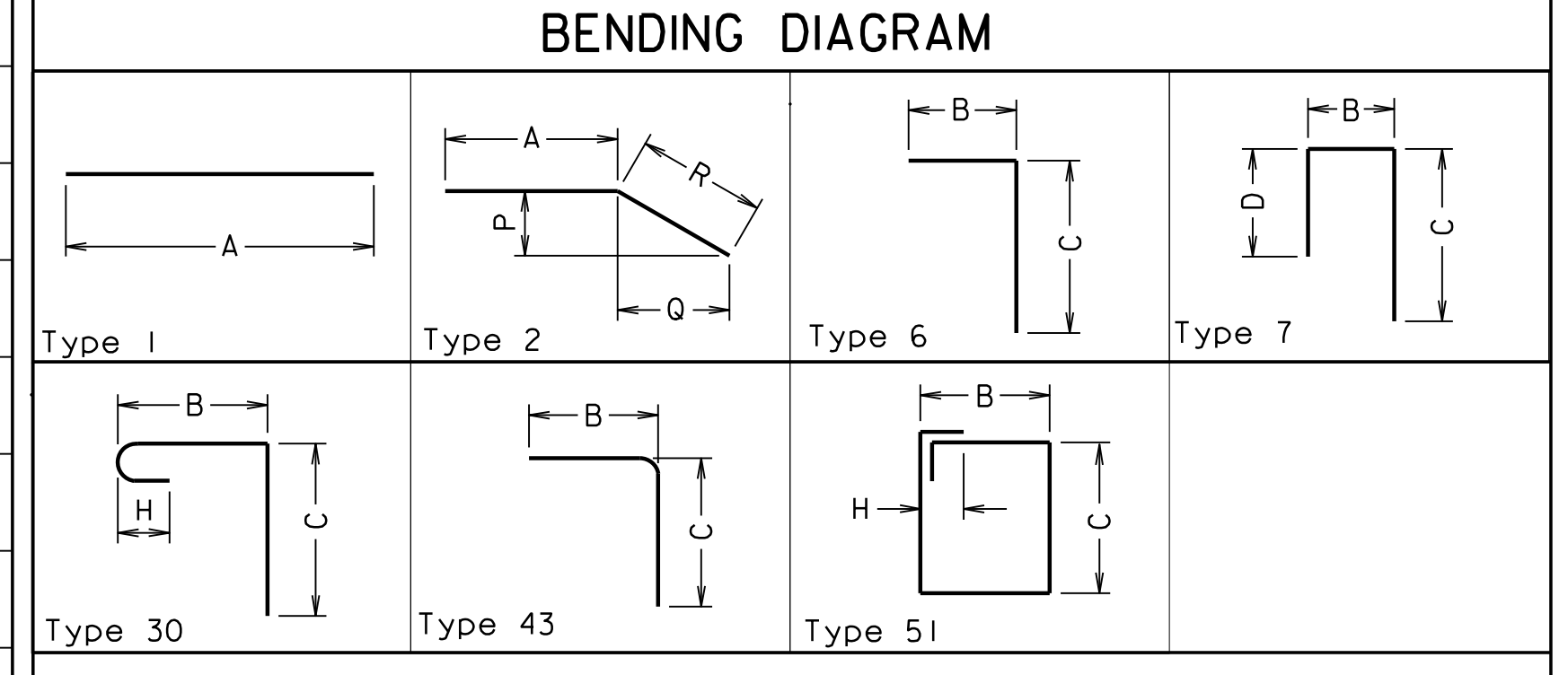

300-46-26.dgn

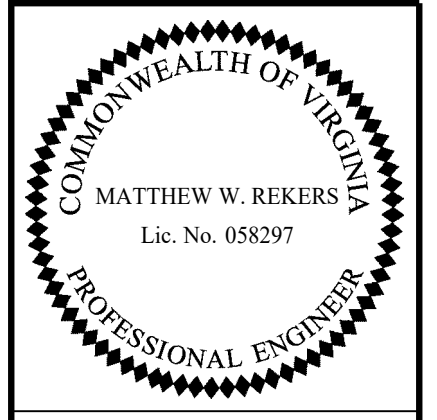

NOTES:

Dimensions in Bending Diagram are out-to-out of bars.

Weights in schedule are based on density of 490 lb/ft³.

If fabrication of deck slab bar is not possible for length detailed and multiple bars are required, bars shall have the least number of Class B splices possible. Splices shall be located approximately at points of contraflexure and splices in alternate bars shall be located in different bays.

Straight bars (top and bottom) may be substituted for truss bars (SB series) in the deck superstructure at no extra cost to the Department.

TRANSYSTEMS
RICHMOND, VA
STRUCTURAL ENGINEER

COMMONWEALTH OF VIRGINIA DEPARTMENT OF TRANSPORTATION STRUCTURE AND BRIDGE DIVISION					
ABUTMENT B REINFORCING STEEL SCHEDULE					
No.	Description	Date	Designed: S.N.	Date	Plan No.
			Drawn: V.A.U.	Apr. 2023	

STATE	FEDERAL AID	STATE	SHEET NO.
ROUTE	PROJECT	ROUTE	PROJECT
VA.		311	0311-080-913, B618
			27

REINFORCING STEEL SCHEDULE							DIMENSION TABLE															
MARK	NO.	BAR SIZE	PIN DIA. FT-IN	LENGTH		WEIGHT (LBS.)	LOCATION	TYPE	A	B	C	D	E	F	G	H	I	J	K	L	V	N
				FT-IN	FT-IN				FT-IN	FT-IN	FT-IN	FT-IN	FT-IN	FT-IN	FT-IN	FT-IN	FT-IN	FT-IN	FT-IN	FT-IN	FT-IN	FT-IN
ES0501	20	5	3 3/4	SUPERSTRUCTURE - CORROSION RES 6-05		134	DECK	7		7	3-03	2-10										
ET0401	4	4		9-01		24	DECK	1	9-01													
ET0402	8	4		7		3	DECK	1	7													
ET0403	8	4		2-04		12	DECK	1	2-04													
SC0501	314	5		9-08		3166	DECK	1	9-08													
SL0401	31	4		89-09		1857	DECK	1	89-08													
TOTAL WEIGHT IN PRECEDING GROUP OF BARS						5196																

DIMENSION VARIATION TABLE									
MARK	NO. EA.	DIMEN- SION	FROM FT-IN	TO FT-IN	VARY BY FT-IN	DIMEN- SION	FROM FT-IN	TO FT-IN	VARY BY FT-IN

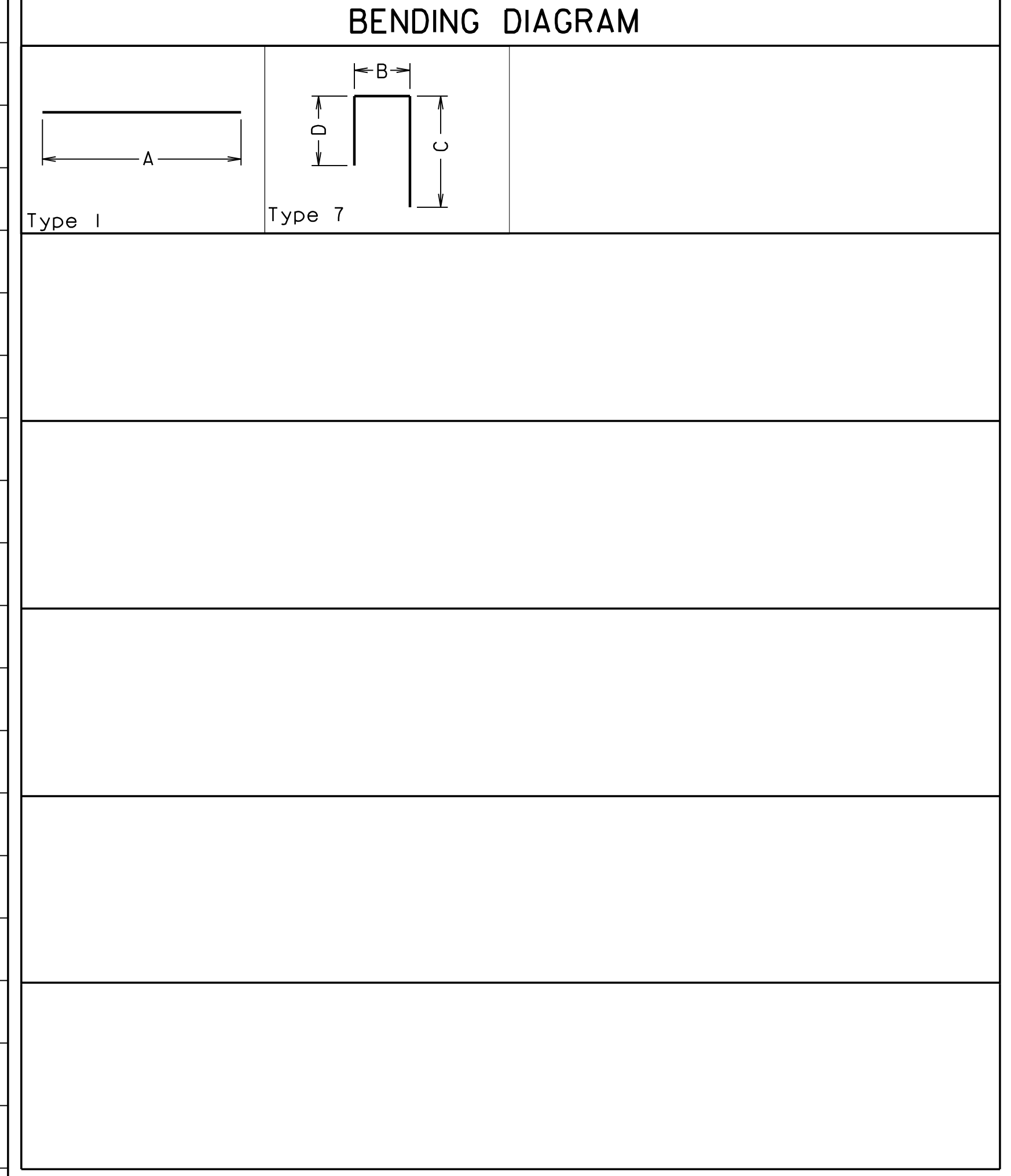

300-46.27.dgn

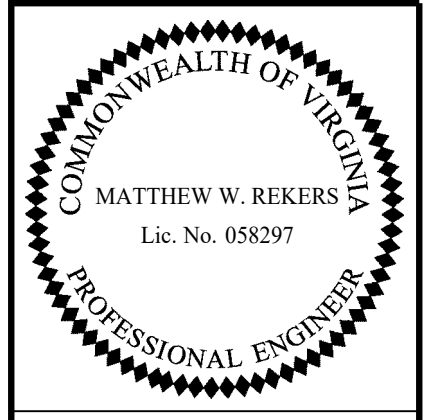

NOTES:

Dimensions in Bending Diagram are out-to-out of bars.

Weights in schedule are based on density of 490 lb/ft³.

If fabrication of deck slab bar is not possible for length detailed and multiple bars are required, bars shall have the least number of Class B splices possible. Splices shall be located approximately at points of contraflexure and splices in alternate bars shall be located in different bays.

Straight bars (top and bottom) may be substituted for truss bars (SB series) in the deck superstructure at no extra cost to the Department.

TRANSYSTEMS
RICHMOND, VA
STRUCTURAL ENGINEER

COMMONWEALTH OF VIRGINIA DEPARTMENT OF TRANSPORTATION STRUCTURE AND BRIDGE DIVISION					
SUPERSTRUCTURE REINFORCING STEEL SCHEDULE					
No.	Description	Date	Designed: S.N.	Date	Plan No.
			Drawn: V.A.U.	Apr. 2023	300-46
			Checked: M.W.R.		27 of 42
Revisions					

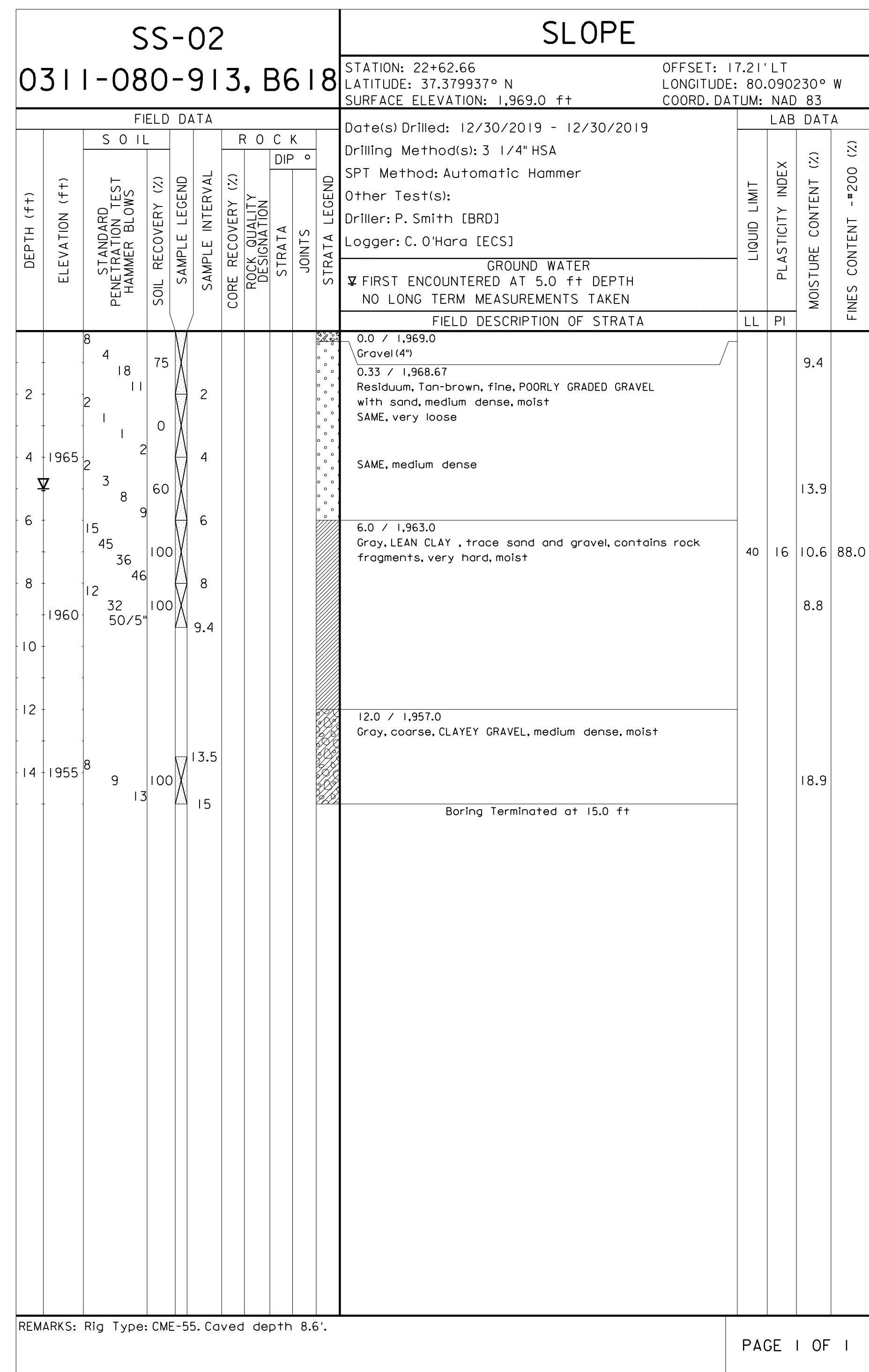
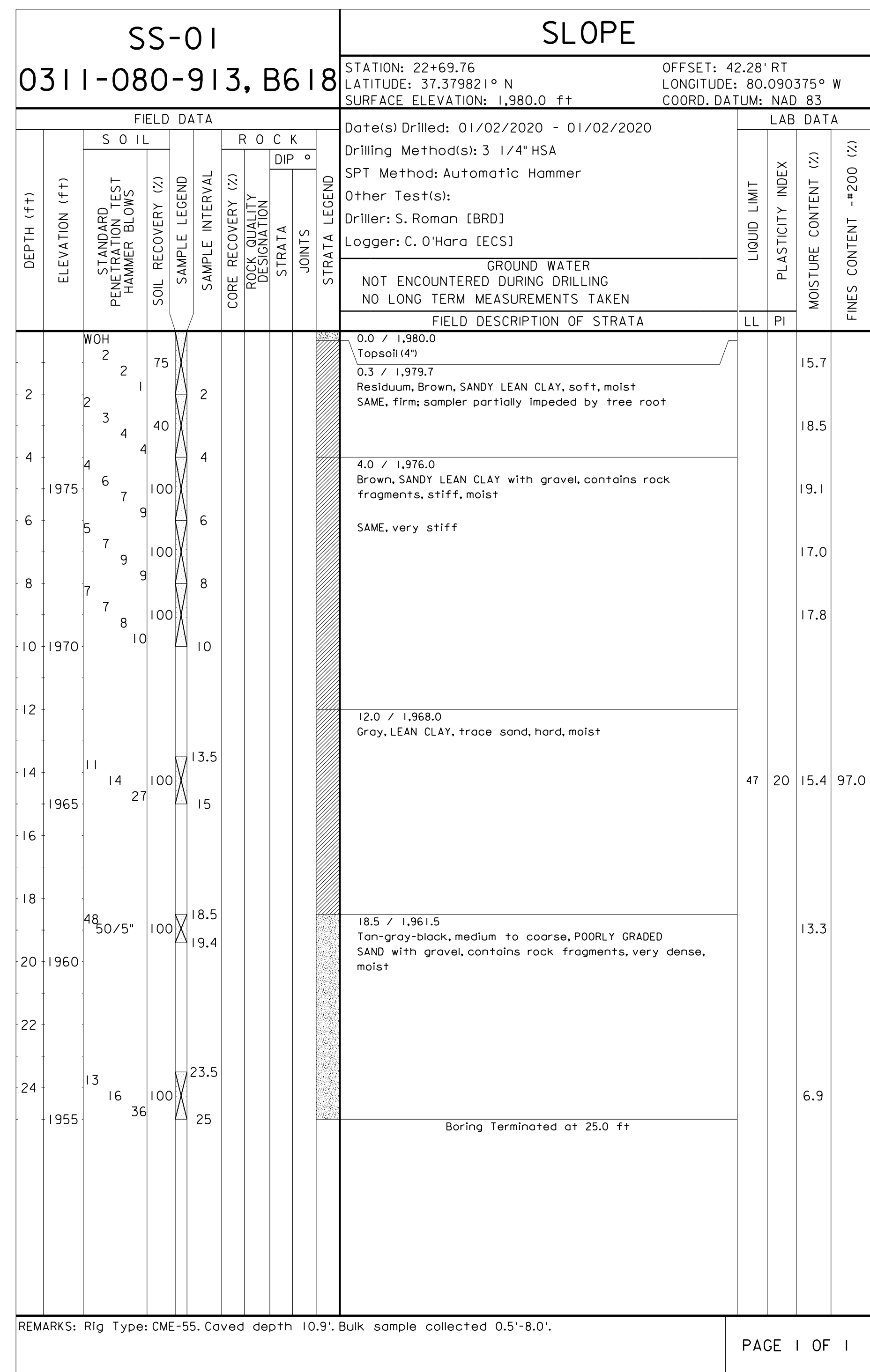
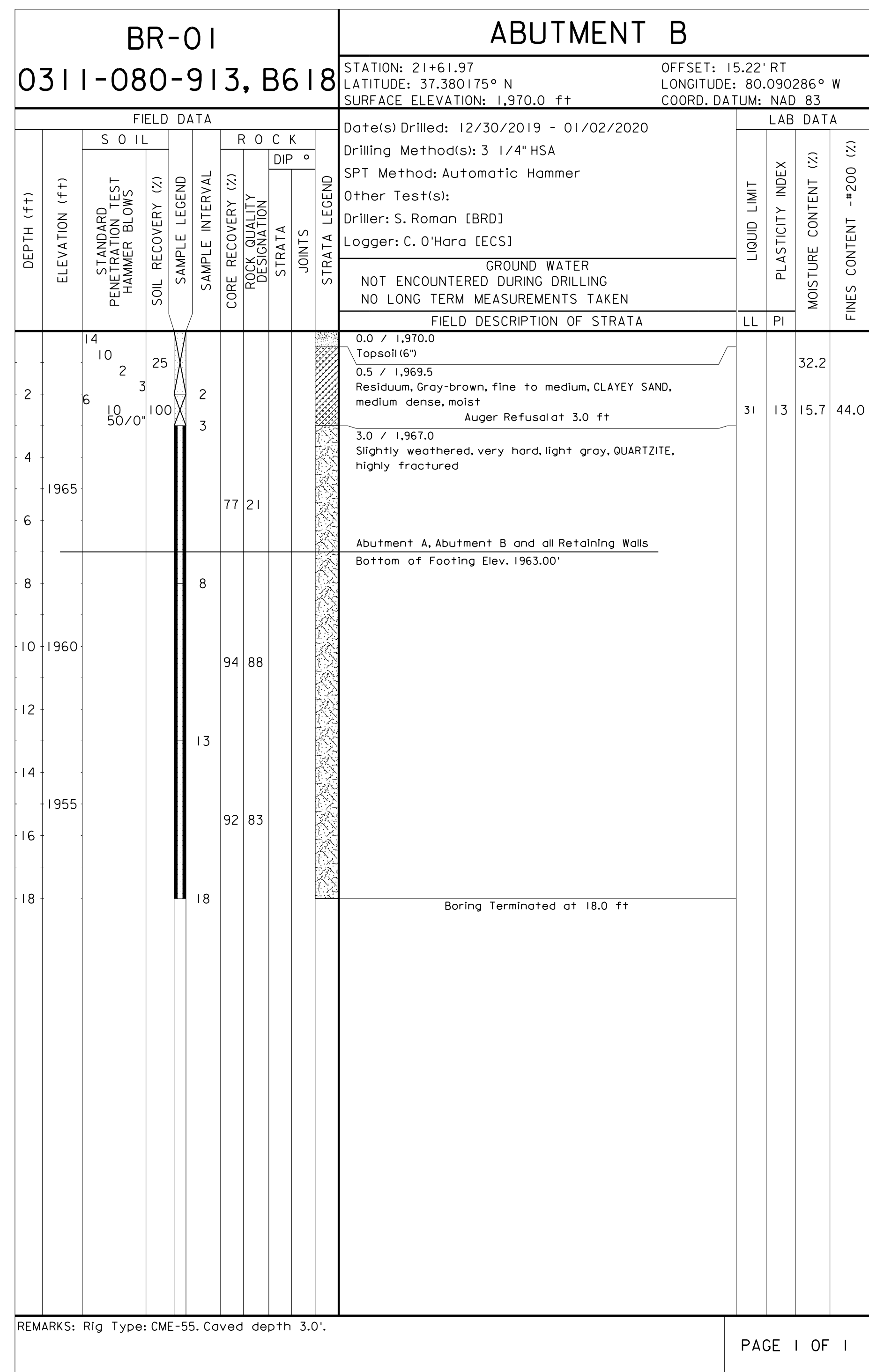

300-46-28.dgn
 SPT_LOG_COMPB: 1884 | BORING_LOGS.GPJ: 10.0.000:092710:10/21/20

The subsurface information shown on the boring logs in these plans was obtained with reasonable care and recorded in good faith solely for use by the Department in establishing design controls for the project. The Department has no reason to suspect that such information is not reasonably accurate as an approximate indication of the subsurface conditions at the sites where the borings were taken. The Department does not in any way warrant or guarantee that such data can be projected as indicative of conditions beyond the limits of the borings shown; and any such projections by bidders are purely interpretive and altogether speculative. Further, the Department does not in any way guarantee, either expressly or by implication, the sufficiency of the information for bid purposes.

The boring logs are made available to bidders in order that they may have access to subsurface data identical to that which is possessed by the Department, and are not intended as a substitute for personal investigation, interpretation and judgment by the bidders.

UPC# 111066

COMMONWEALTH OF VIRGINIA DEPARTMENT OF TRANSPORTATION			
STRUCTURE AND BRIDGE DIVISION			
0311-080-913, B618 ENGINEERING GEOLOGY (1 OF 2)			
No.	Description	Date	Drilled: BRD Logged: ECS Checked: MWR
	Revisions	Apr. 2023	Plan No. 300-46 Sheet No. 28 of 42

STATE	FEDERAL AID	STATE	SHEET
ROUTE	PROJECT	ROUTE	PROJECT
VA.		311	0311-080-913, B618
			29

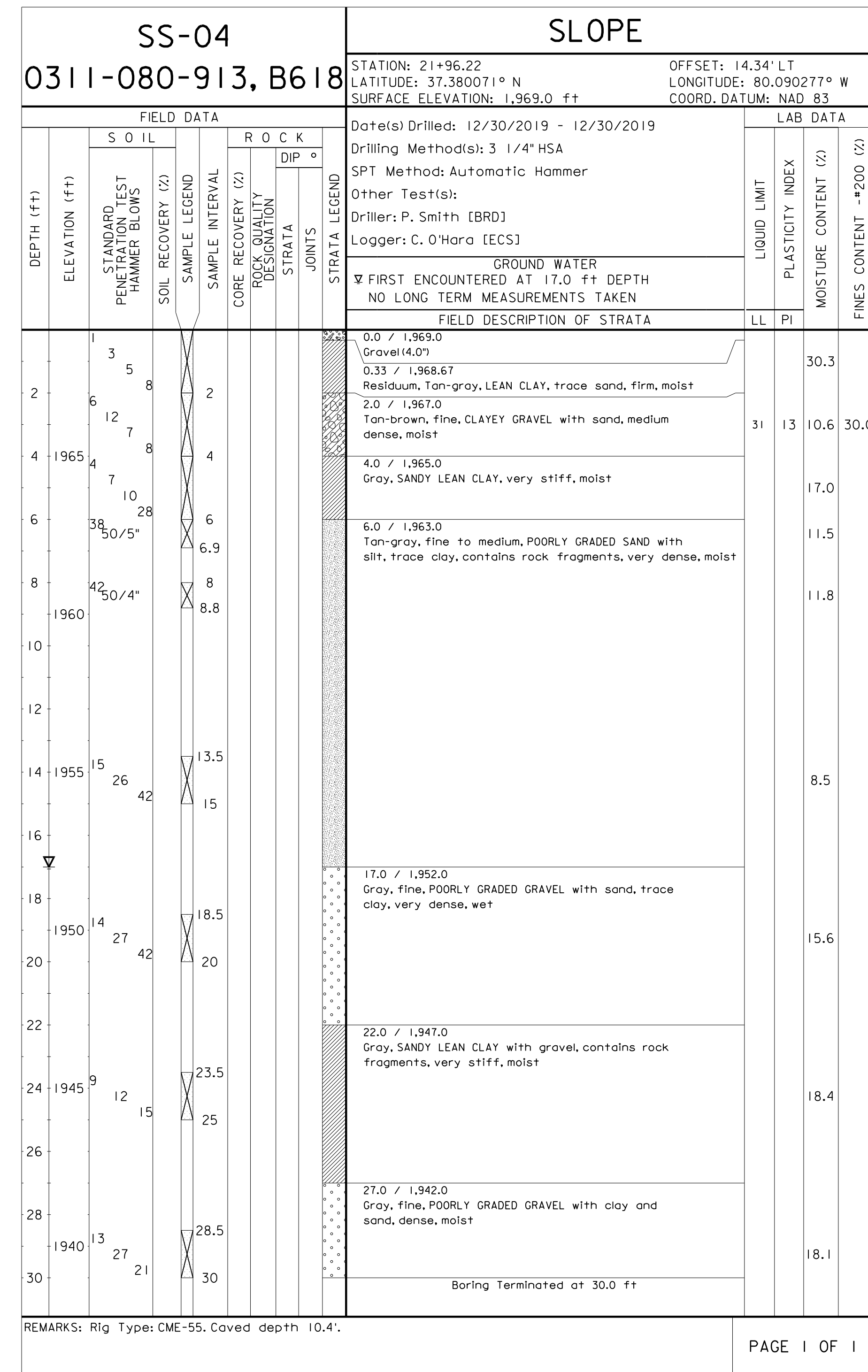
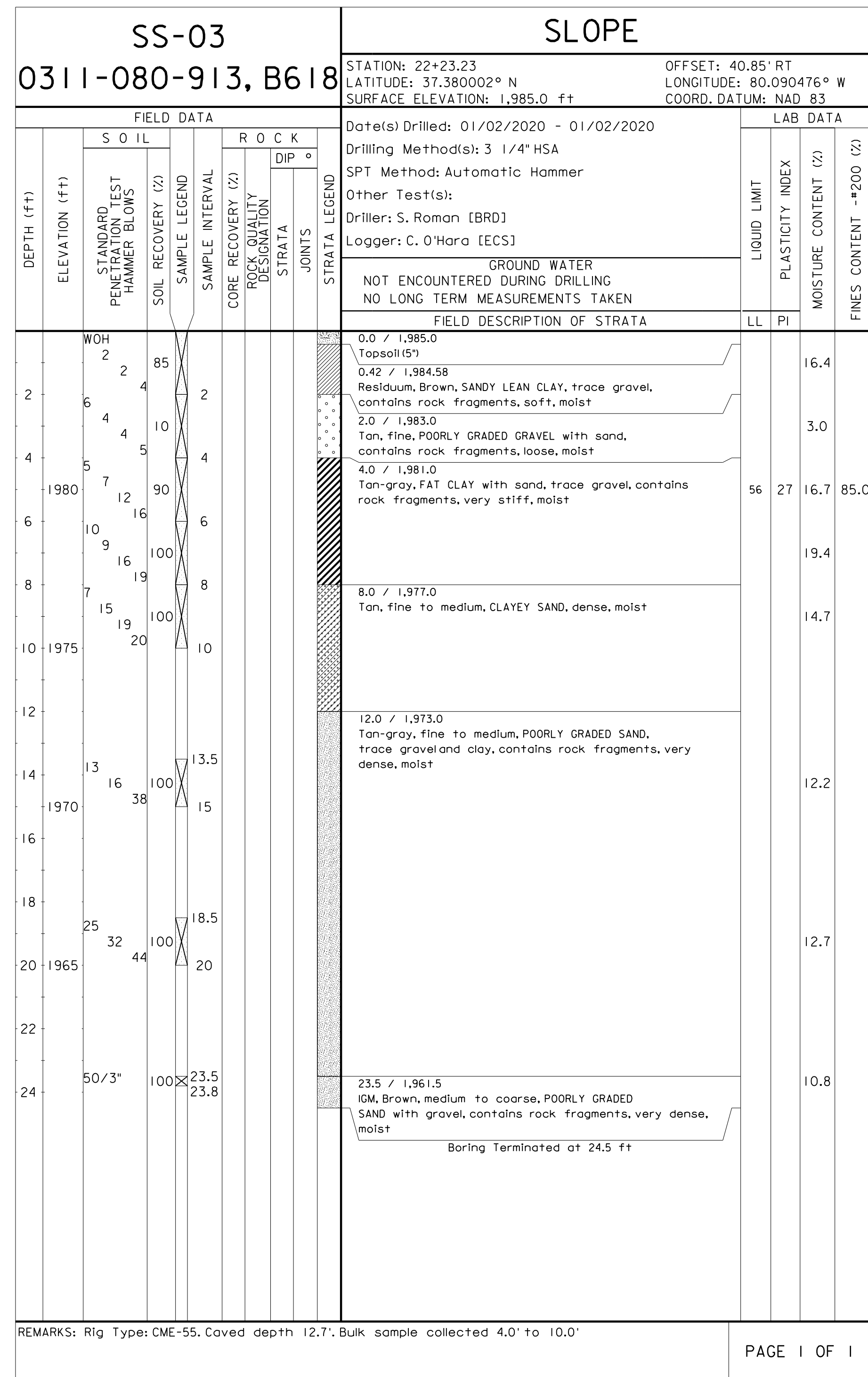

The subsurface information shown on the boring logs in these plans was obtained with reasonable care and recorded in good faith solely for use by the Department in establishing design controls for the project. The Department has no reason to suspect that such information is not reasonably accurate as an approximate indication of the subsurface conditions at the sites where the borings were taken. The Department does not in any way warrant or guarantee that such data can be projected as indicative of conditions beyond the limits of the borings shown, and any such projections by bidders are purely interpretive and altogether speculative. Further, the Department does not in any way guarantee, either expressly or by implication, the sufficiency of the information for bid purposes.

The boring logs are made available to bidders in order that they may have access to subsurface data identical to that which is possessed by the Department, and are not intended as a substitute for personal investigation, interpretation and judgment by the bidders.

SPT.LOG.COMPB:18841 BORING LOGS.GPJ:10.0.000:092710:10/21/20

UPC# 111066

COMMONWEALTH OF VIRGINIA			
DEPARTMENT OF TRANSPORTATION			
STRUCTURE AND BRIDGE DIVISION			
0311-080-913, B618			
ENGINEERING GEOLOGY (2 OF 2)			
No.	Description	Date	Drilled: BRD..... Logged: ECS..... Checked: MWR.....
	Revisions	Apr. 2023	Plan No. 300-46 Sheet No. 29 of 42

300-46_29.dgn

Notes:

The retaining wall layout is for the purpose of locating fill slopes and footings for retaining walls. For details of neatwork, see Retaining Wall sheets.

Material in the abutment select backfill zone shall be Select Material Type I, minimum CBR 30, and shall be compacted in accordance with Sections 303 and 305 of the VDOT Road and Bridge Specifications. 21A or 21B may be substituted for Select Material Type I, minimum CBR 30, at no additional cost to the Department.

In cut situations, material with strength characteristics greater than the select backfill may be left in place.

The final depth of the embankment side slopes shall be regular embankment material placed and finished as required.

For boring logs, see sheets 28 and 29.

For metal stair concrete pilaster details, see sheets 9, 36 and 41.

For metal stair concrete footing details, see sheets 36 and 41.

⊙ - Denotes boring location.

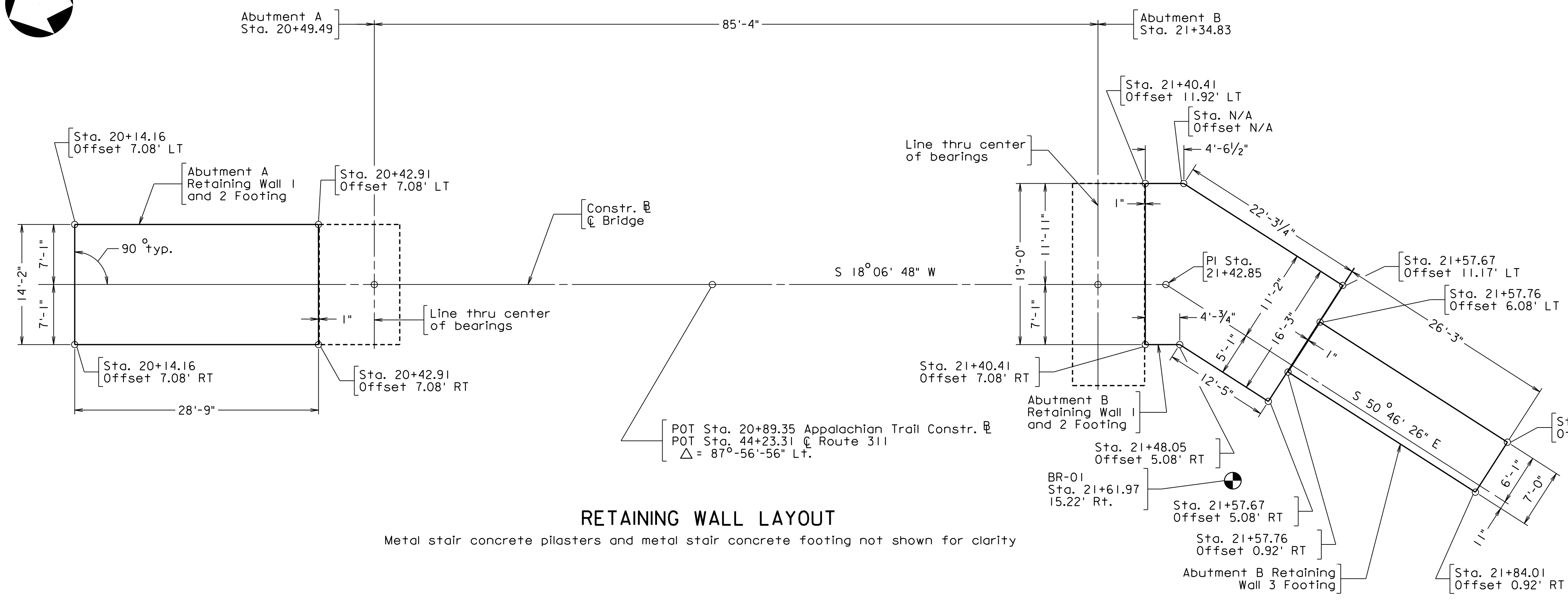
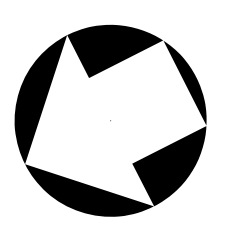

RETAINING WALL LAYOUT

Metal stair concrete pilasters and metal stair concrete footing not shown for clarity

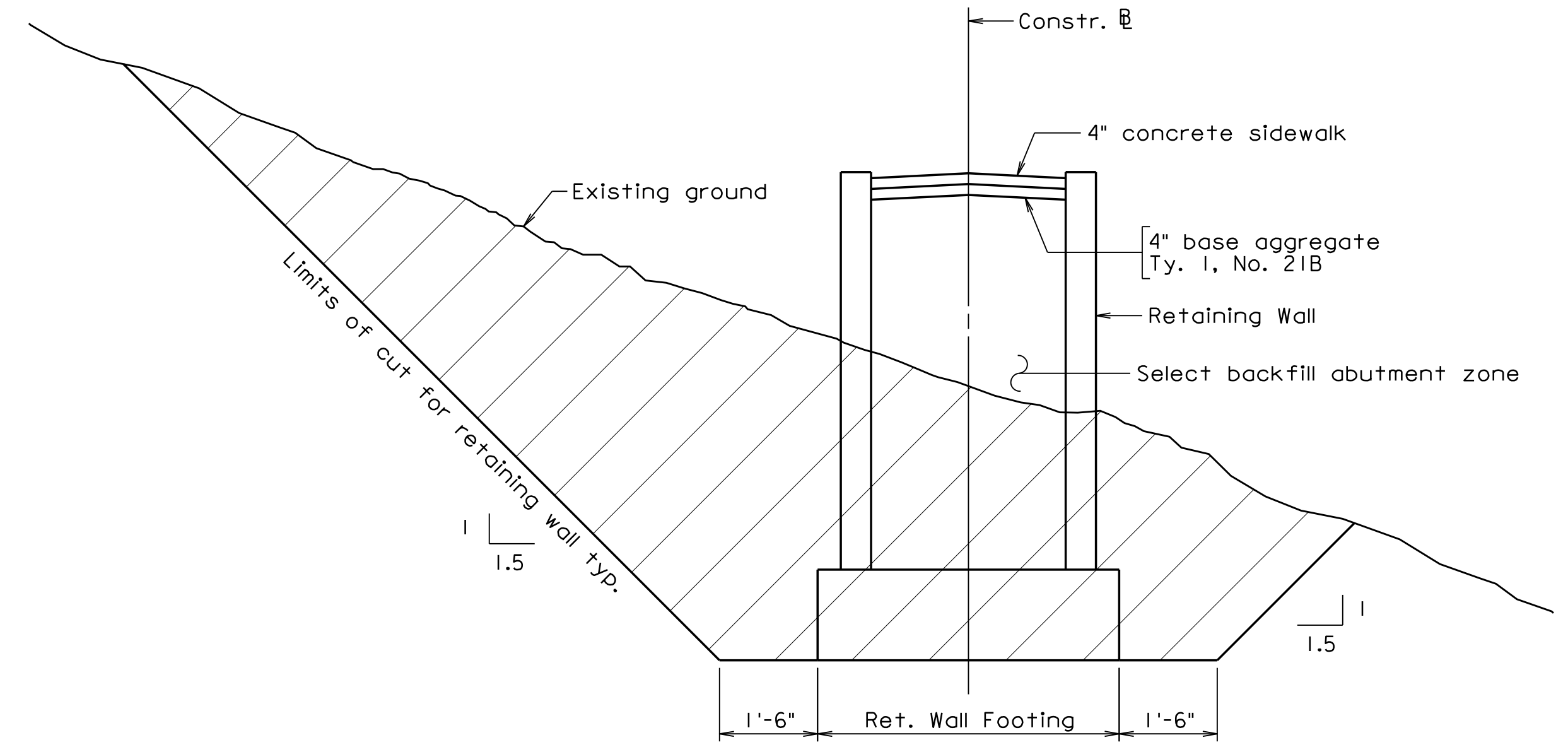

SUGGESTED SECTION THROUGH RETAINING WALL - CUT SECTION
Not to scale

To be paid for as structure excavation

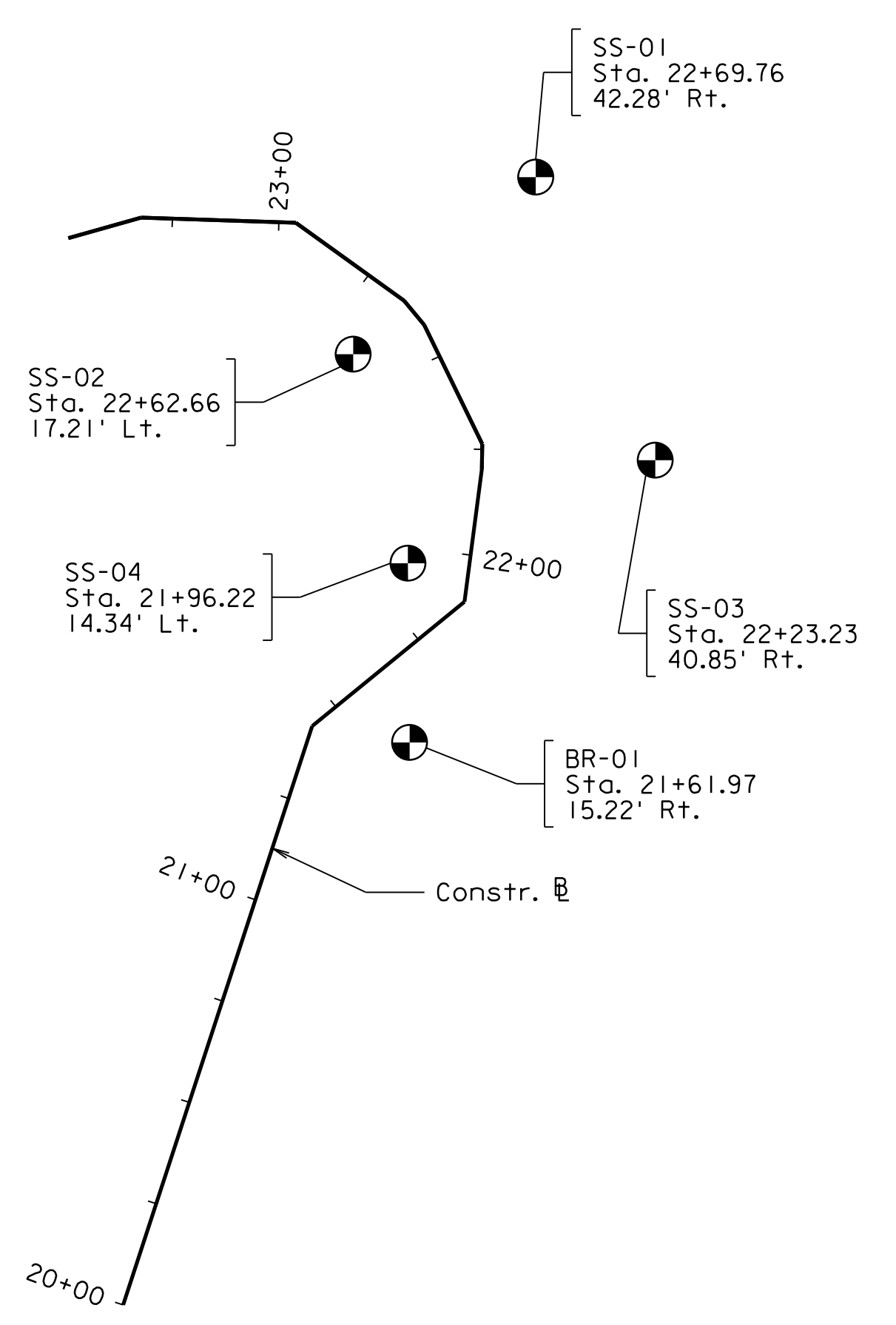

BORING PLAN LAYOUT
Not to scale

Scale: 1/8" = 1'-0" unless noted otherwise © 2023, Commonwealth of Virginia

SPREAD FOOTING DATA TABLE					
Retaining Wall Unit	Anticipated Bearing Material	SERVICE LIMIT STATE		STRENGTH LIMIT STATE	
		Tolerable Settlement (inches)	Maximum Applied Bearing Pressure (tsf)	Maximum Factored Bearing Pressure (tsf)	Required Nominal Bearing Resistance (tsf)
Abutment A Retaining Walls 1 and 2 Footing	Firm material	N/A	1.5	2.0	4.5
Abutment B Retaining Walls 1 and 2 Footing	Firm material	N/A	1.4	1.8	4.0
Abutment B Retaining Wall 3 Footing	Firm material	N/A	2.3	3.2	7.2

* The larger of these two values, as well as the Anticipated Bearing Material, shall be verified by the Inspector or Engineer-of-Record prior to placing the footing concrete.

300-46-30.dgn

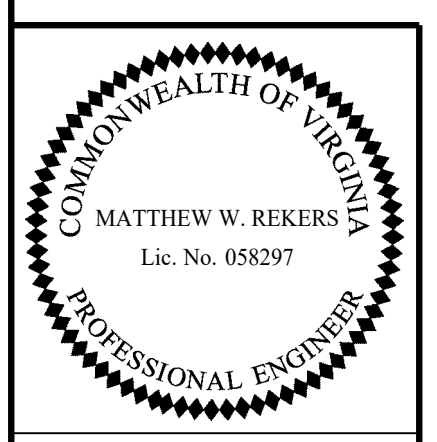

TRANSYSTEMS
RICHMOND, VA
STRUCTURAL ENGINEER

COMMONWEALTH OF VIRGINIA DEPARTMENT OF TRANSPORTATION STRUCTURE AND BRIDGE DIVISION					
RETAINING WALL LAYOUT					
No.	Description	Date	Designed: S.N.....	Date	Plan No.
			Drawn: V.A.U.....	Apr. 2023	300-46
			Checked: M.W.R.....		30 of 42
Revisions					

STATE	FEDERAL AID	STATE	SHEET
ROUTE	PROJECT	ROUTE	PROJECT
VA.		311	0311-080-913, B618
			31

Note:

Place reinforcing to avoid weephole. 6" \emptyset hole centered on the weephole shall be cut in the plastic portion of the wall drain to connect it with the weephole.

Bottom of footing elevation shall not be lowered by more than one (1) foot.

For Weephole Reinforcement Detail and Handrail Anchor Bolt Details, see sheet 13.

For Abutment A Reinforcement Schedule, see sheet 25.

For Footing Plan, see Sheet 32.

For Architectural Treatment and Coping Details, see sheet 38.

See VDOT Road and Bridge Standard HR-1 (Page 601.05) for HR-1 Type I Handrail. Handrails shall be painted brown.

See VDOT Road and Bridge Standard S-2 (Pages 601.03 and 601.04) for Concrete Stairs.

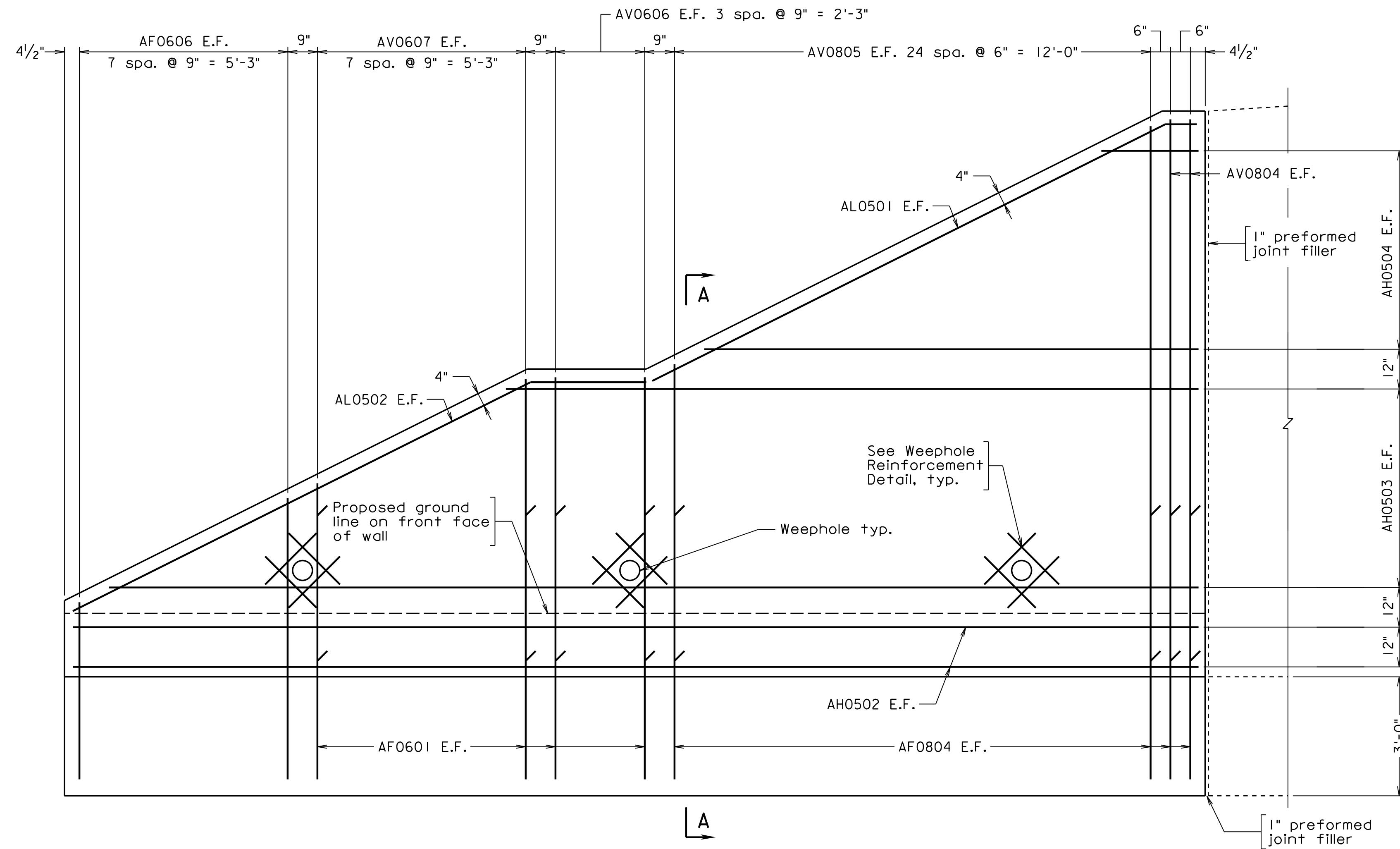

ABUTMENT A RETAINING WALL I ELEVATION

Abutment A Retaining Wall 1 shown, Abutment A Retaining Wall 2 similar

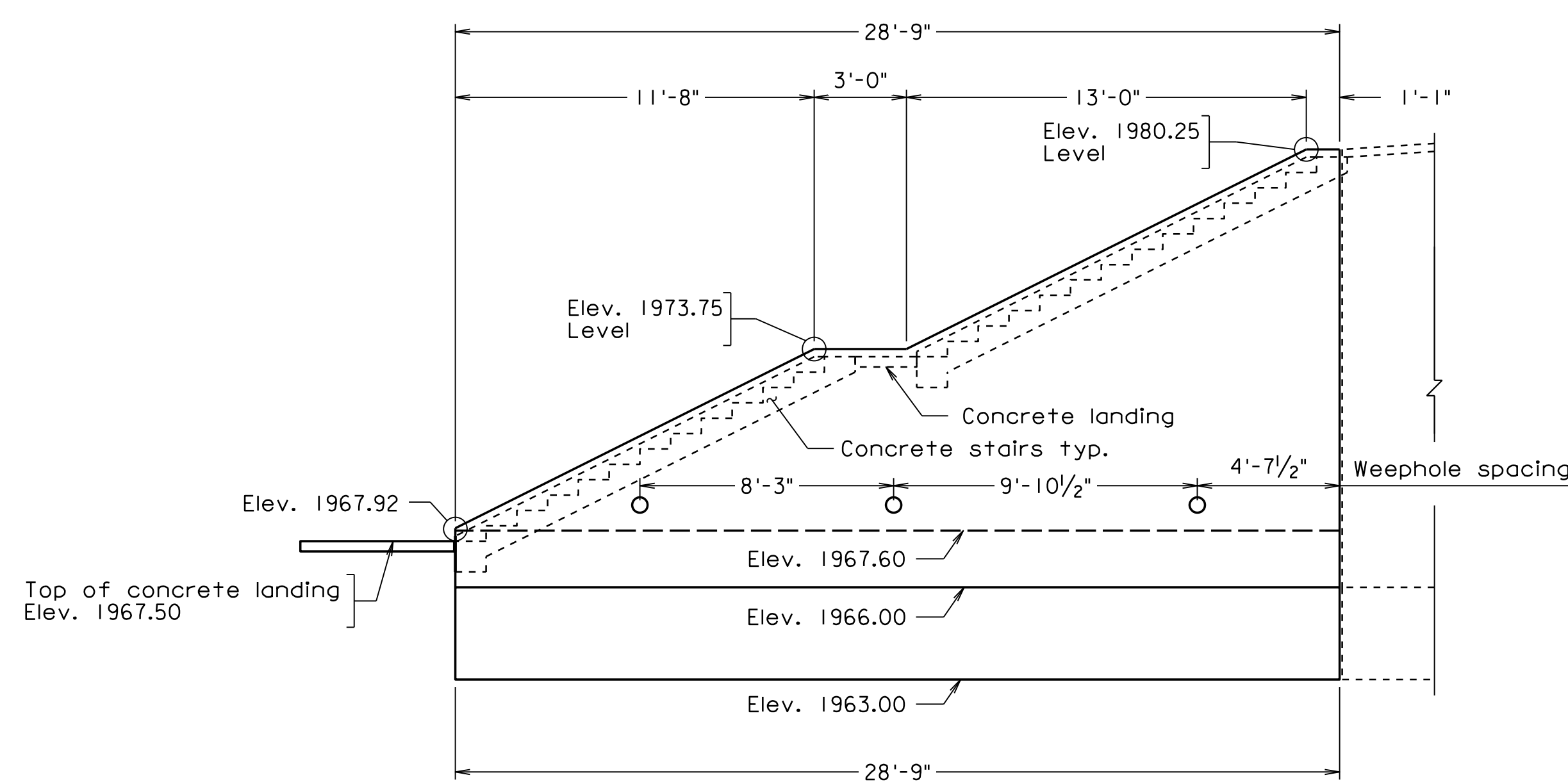

WALL GEOMETRY

Abutment A Retaining Wall 1 shown, Abutment A Retaining Wall 2 similar

Scale: 1/4" = 1'-0"

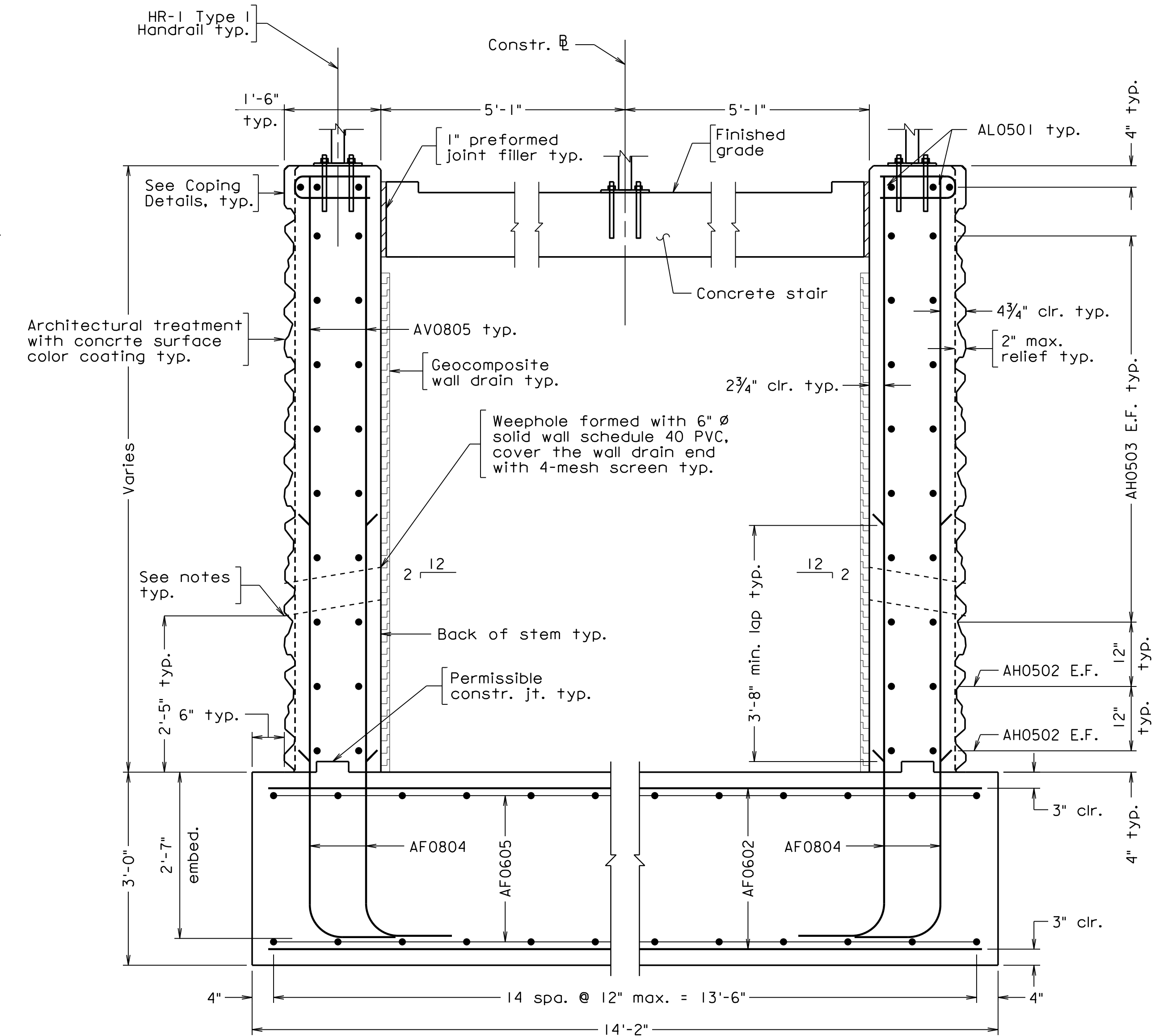

SECTION A-A

Scale: 3/4" = 1'-0"

300-46-31.dgn

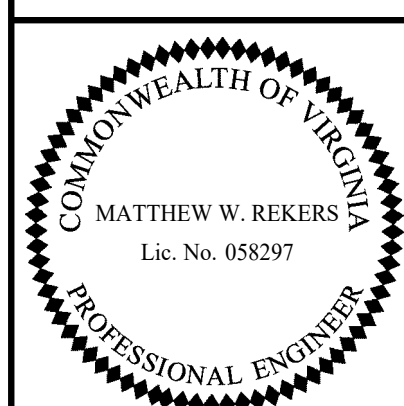

TRANSYSTEMS
RICHMOND, VA
STRUCTURAL ENGINEER

Scale: 1/2" = 1'-0" unless otherwise noted

© 2023, Commonwealth of Virginia

COMMONWEALTH OF VIRGINIA DEPARTMENT OF TRANSPORTATION STRUCTURE AND BRIDGE DIVISION	
ABUTMENT A RETAINING WALLS 1 AND 2	
No.	Description
Revisions	
Designed: V.A.J.	Date
Drawn: M.W.R.	Apr. 2023
Checked: M.W.R.	Plan No. 300-46
	Sheet No. 31 of 42

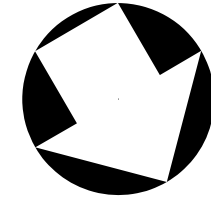

STATE	FEDERAL AID		STATE		SHEET
ROUTE	PROJECT		ROUTE	PROJECT	NO.
VA.	—		311	0311-080-913, B618	32

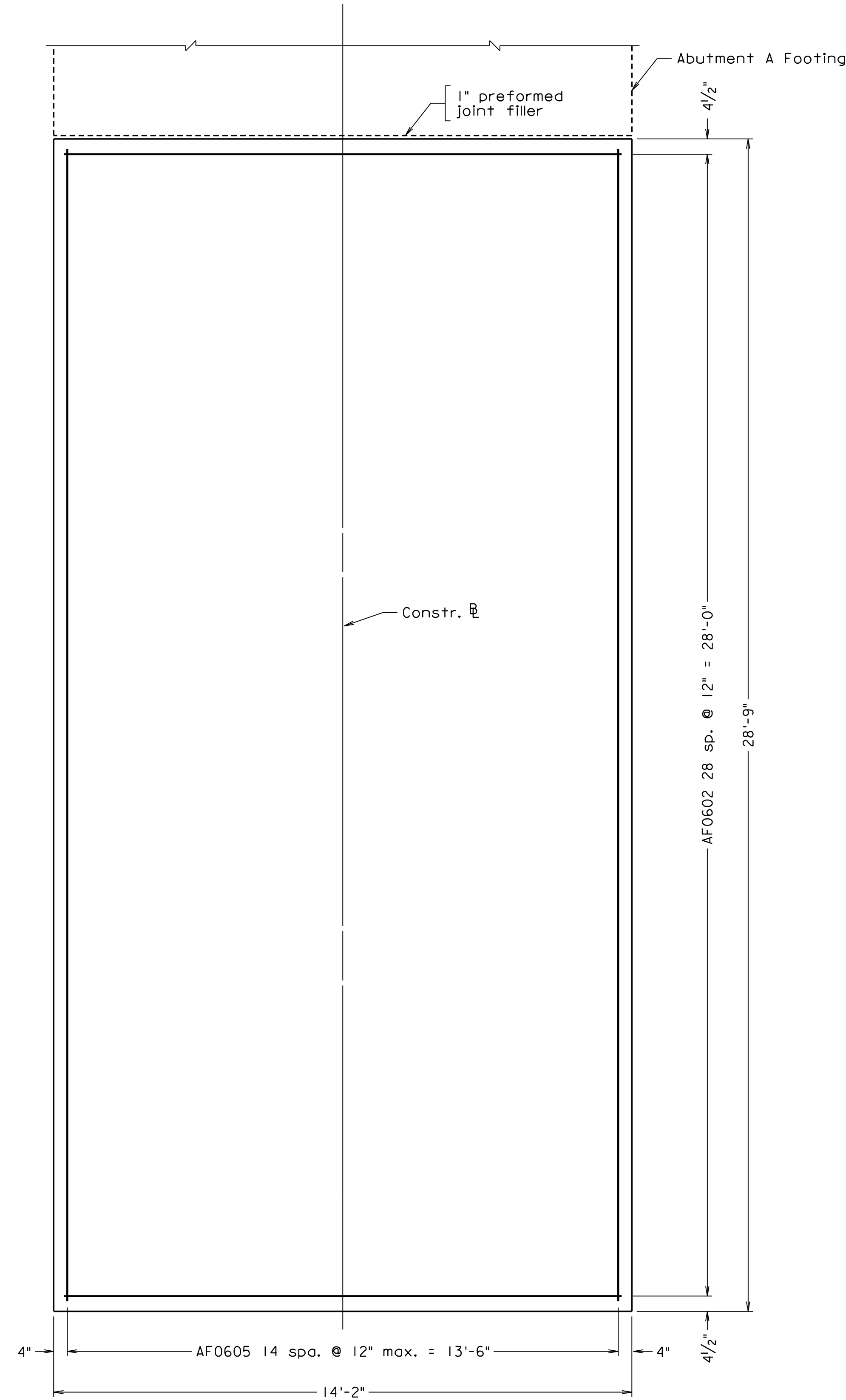

Note:
For Abutment A Reinforcement Schedule, see sheet 25.

FOOTING PLAN

Top reinforcing shown, bottom similar

Scale: 1/2" = 1'-0" unless otherwise noted

© 2023, Commonwealth of Virginia

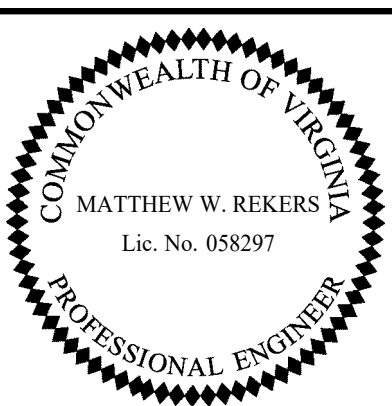

TRANSYSTEMS
RICHMOND, VA
STRUCTURAL ENGINEER

COMMONWEALTH OF VIRGINIA DEPARTMENT OF TRANSPORTATION					
STRUCTURE AND BRIDGE DIVISION					
ABUTMENT A RETAINING WALLS 1 AND 2 FOOTING					
No.	Description	Date	Designed: V.A.J./...	Date	Plan No.
			Drawn: I.B.W./...	Apr. 2023	300-46
			Checked: M.W.R./...		Sheet No.
Revisions					32 of 42

300-46-32.dgn

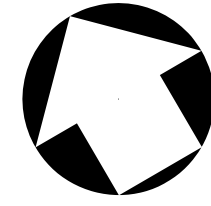

STATE	FEDERAL AID	STATE	SHEET
ROUTE	PROJECT	ROUTE	PROJECT
VA.		311	0311-080-913, B618
			33

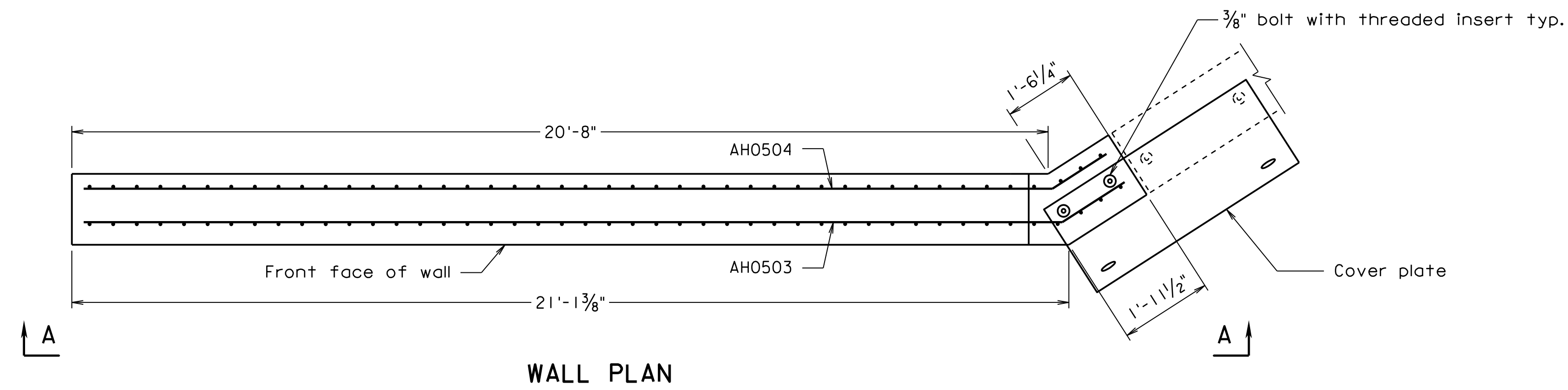

Note:

Place reinforcing to avoid weephole. 6" \emptyset hole centered on the weephole shall be cut in the plastic portion of the wall drain to connect it with the weephole.

Bottom of footing elevation shall not be lowered by more than one (1) foot.

For Weephole Reinforcement Detail and Handrail Anchor Bolt Details, see sheet 13.

For Abutment B Reinforcement Schedule, see sheet 26.

For Threaded Insert Detail, and additional details concerning cover plate, backer plate and threaded inserts, see sheet 34.

For Footing Plan, see sheet 36.

For Architectural Treatment and Coping Details, see sheet 39.

See VDOT Road and Bridge Standard HR-1 (Page 601.05) for HR-1 Type II Handrail. Handrails shall be painted brown.

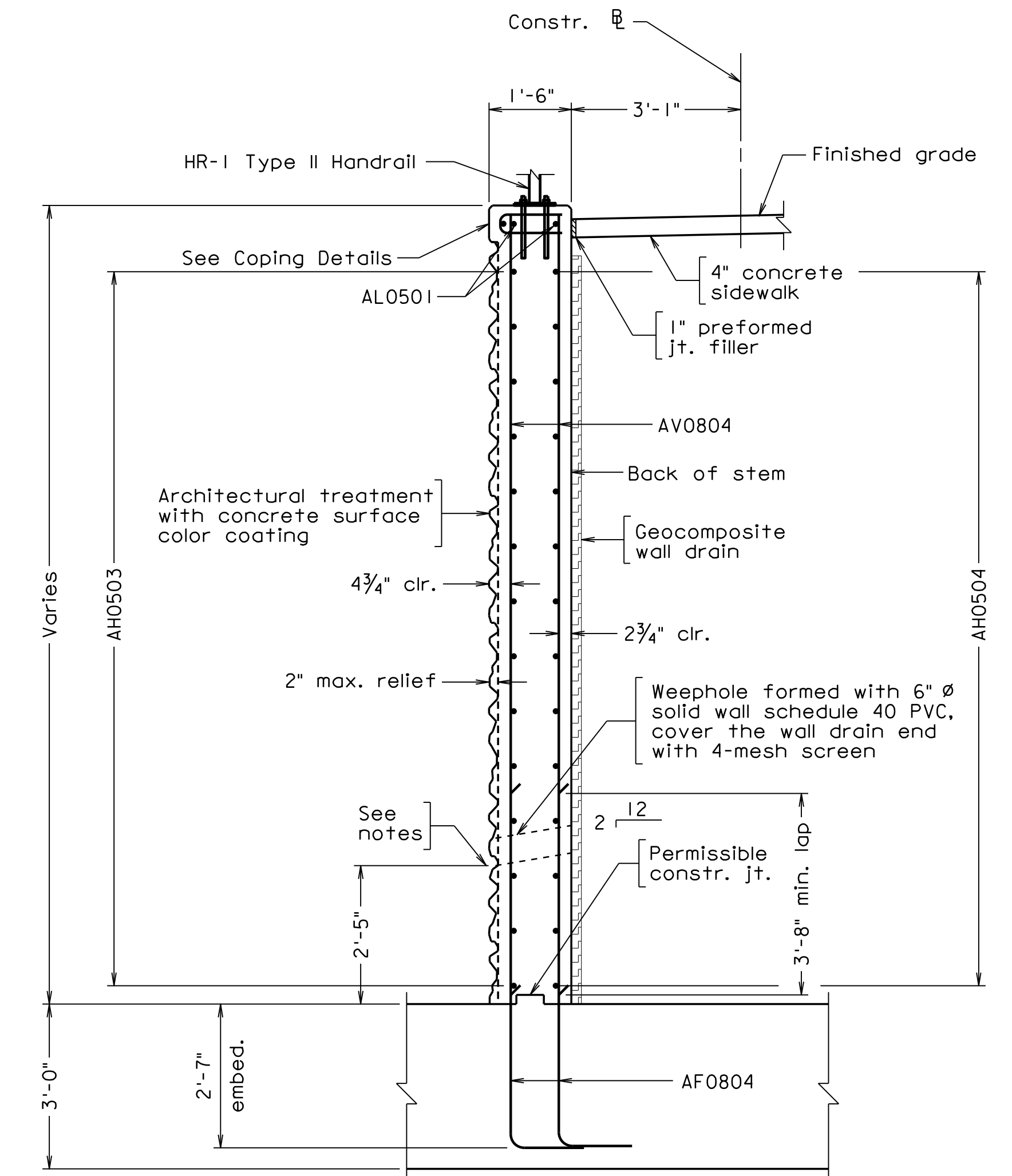
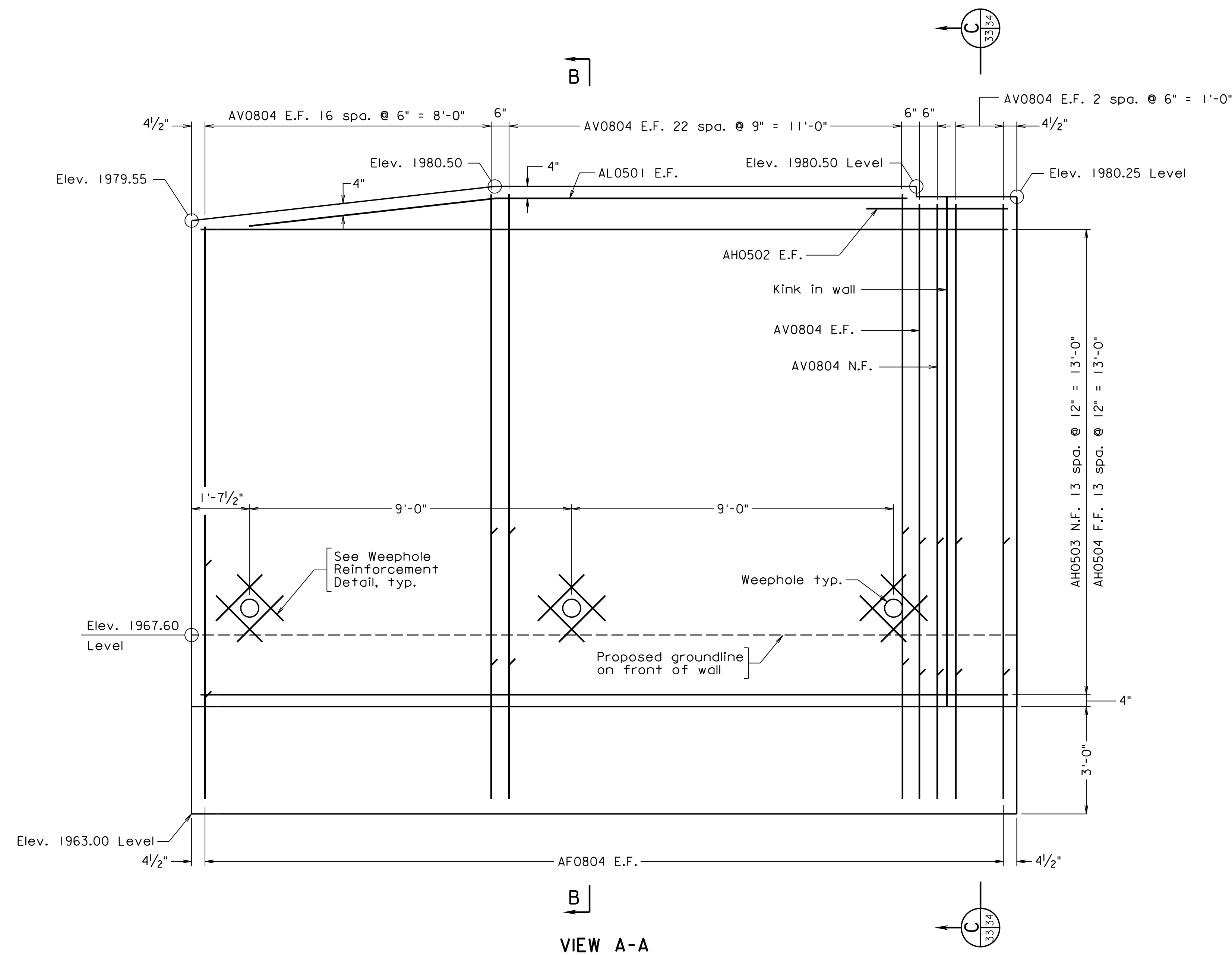

300-46-33.dgn

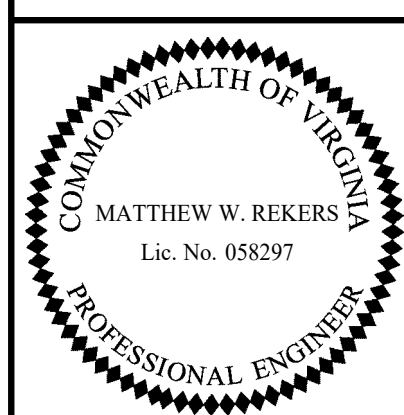

TRANSYSTEMS
RICHMOND, VA
STRUCTURAL ENGINEER

Scale: 1/2" = 1'-0" unless otherwise noted

© 2023, Commonwealth of Virginia

COMMONWEALTH OF VIRGINIA DEPARTMENT OF TRANSPORTATION STRUCTURE AND BRIDGE DIVISION					
ABUTMENT B RETAINING WALL 1 (1 OF 2)					
No.	Description	Date	Designed: V.A.J.	Date	Plan No.
			Drawn: L.B.W.	Apr. 2023	300-46
			Checked: M.W.R.		33 of 42
Revisions					

STATE	FEDERAL AID	STATE	SHEET
ROUTE	PROJECT	ROUTE	PROJECT
VA.		311	0311-080-913, B618
			34

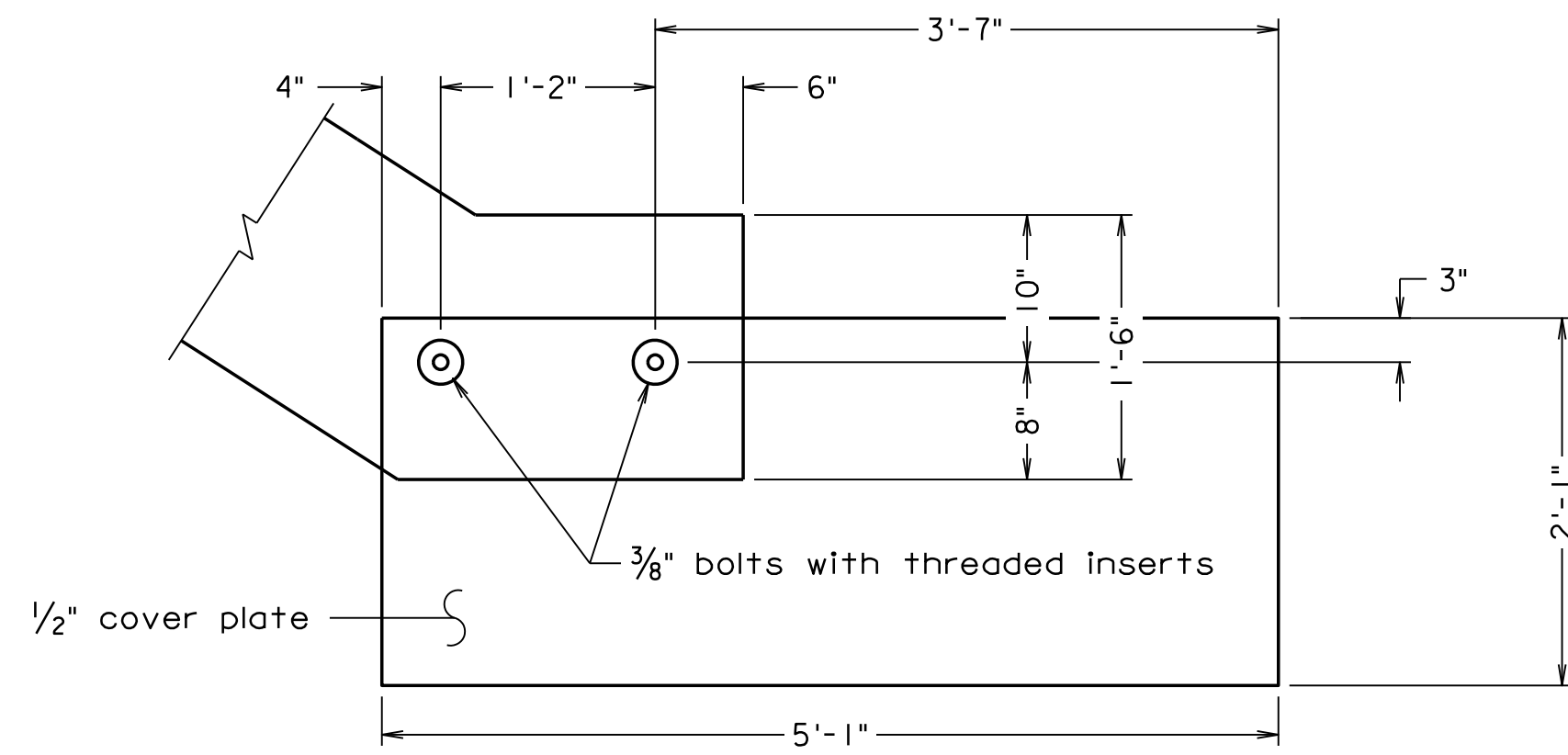

THREADED INSERT DETAIL
Scale: 1" = 1'-0"

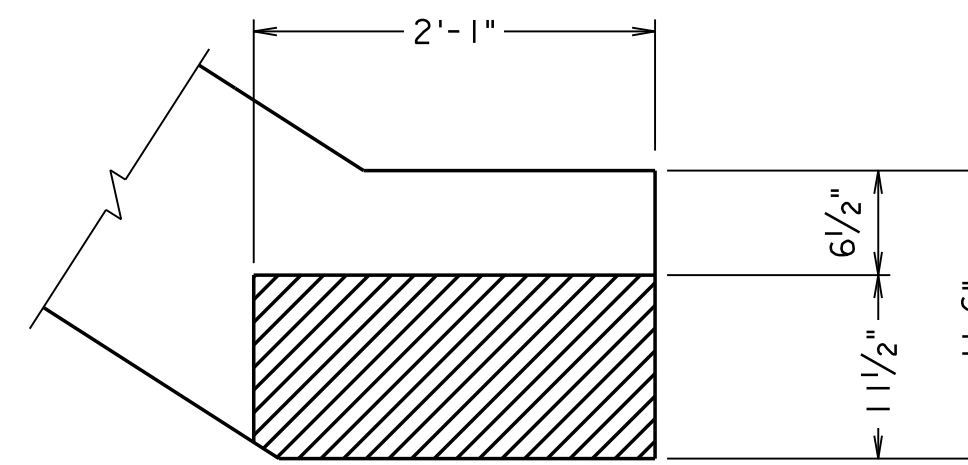

RECESS DETAIL
Scale: 1" = 1'-0"

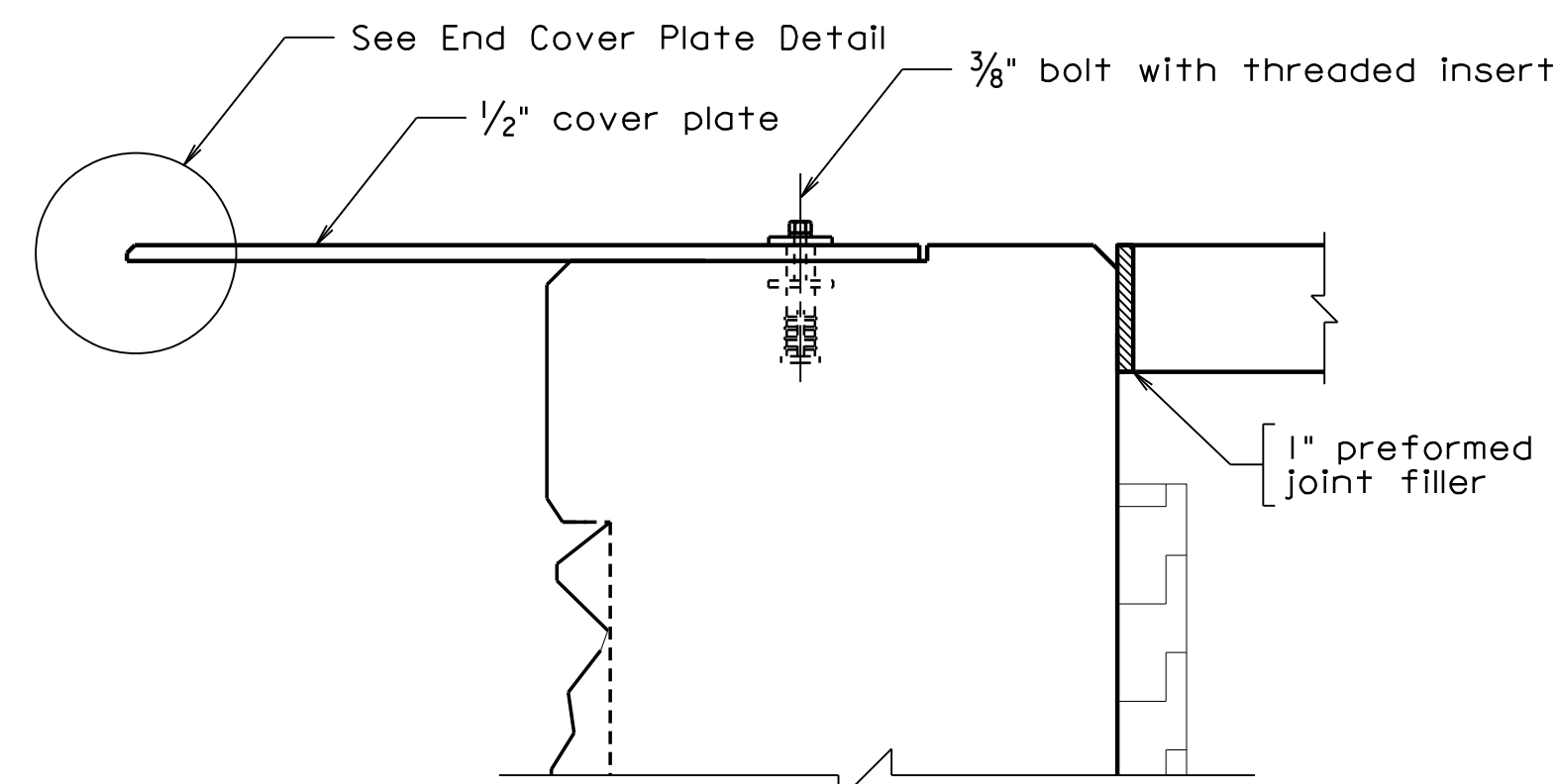

DETAIL A
Scale: 2" = 1'-0"

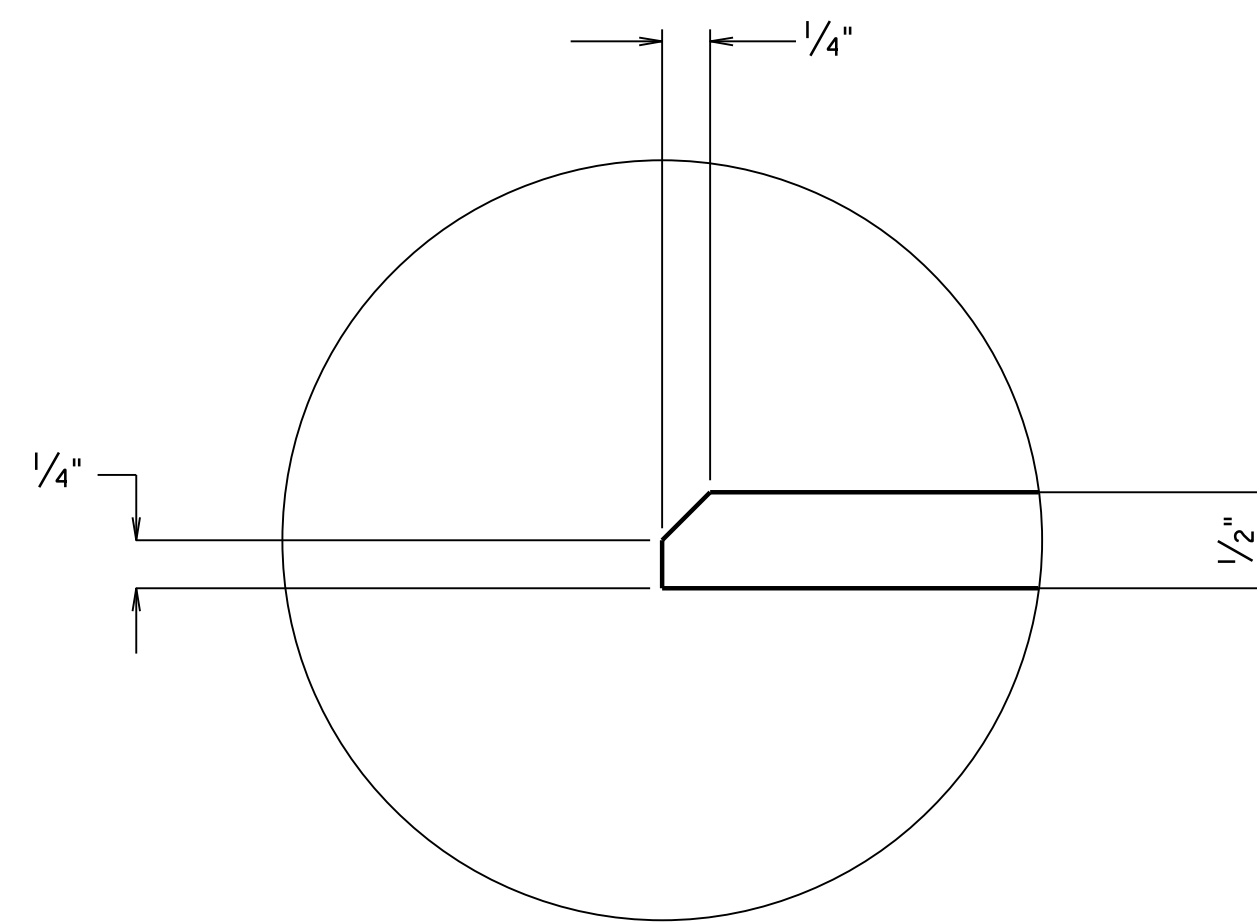

END COVER PLATE DETAIL
Scale: Full Size

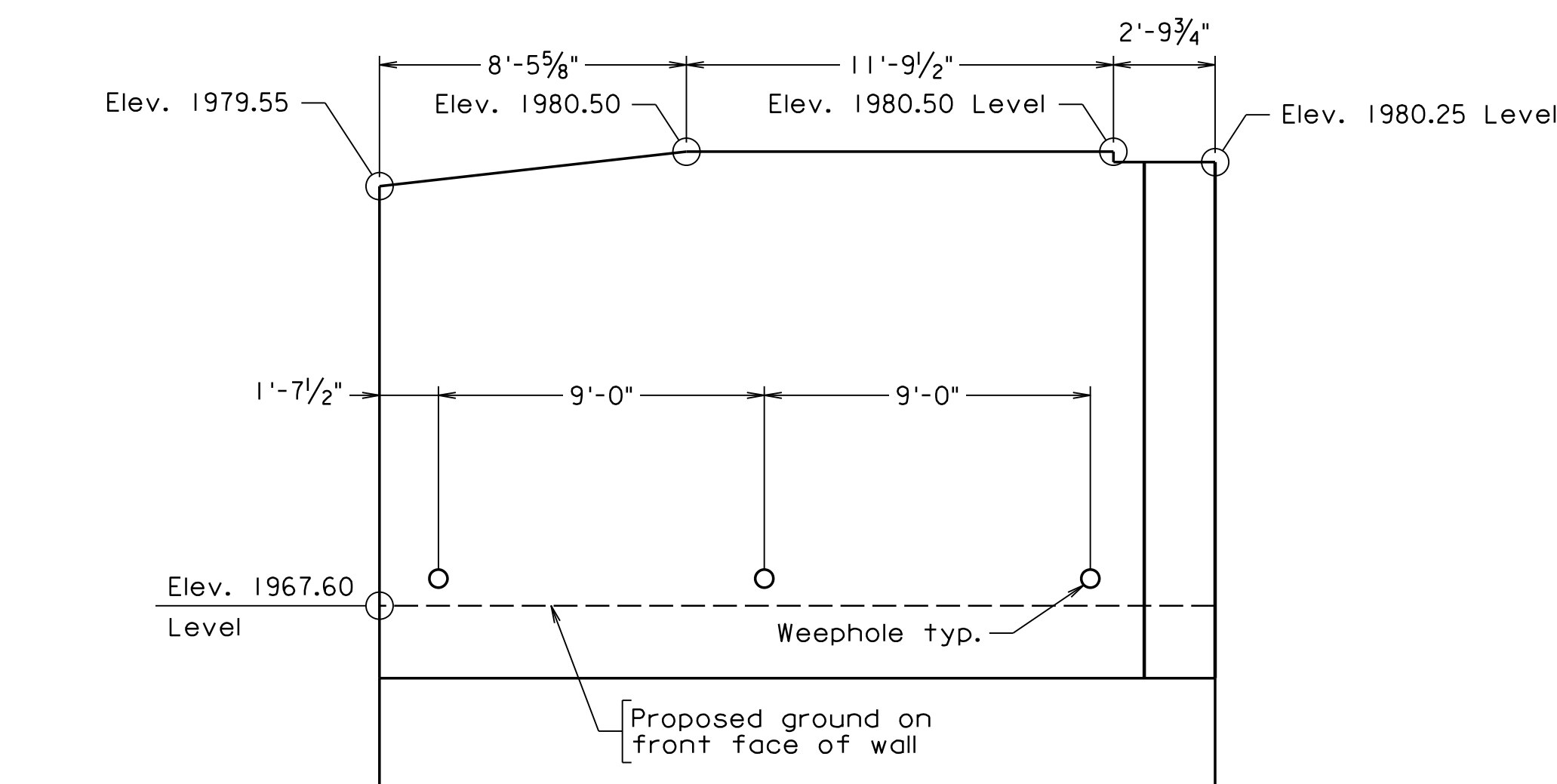

ABUTMENT B RETAINING WALL I GEOMETRY
Scale: 1/4" = 1'-0"
Dimensions shown on front face

Note:
For Abutment B Reinforcement Schedule, see sheet 26.
Place reinforcing to avoid weephole. 6" Ø hole centered on the weephole shall be cut in the plastic portion of the wall drain to connect it with the weephole.
Cost of joint filler shall be included in the price for substructure concrete.

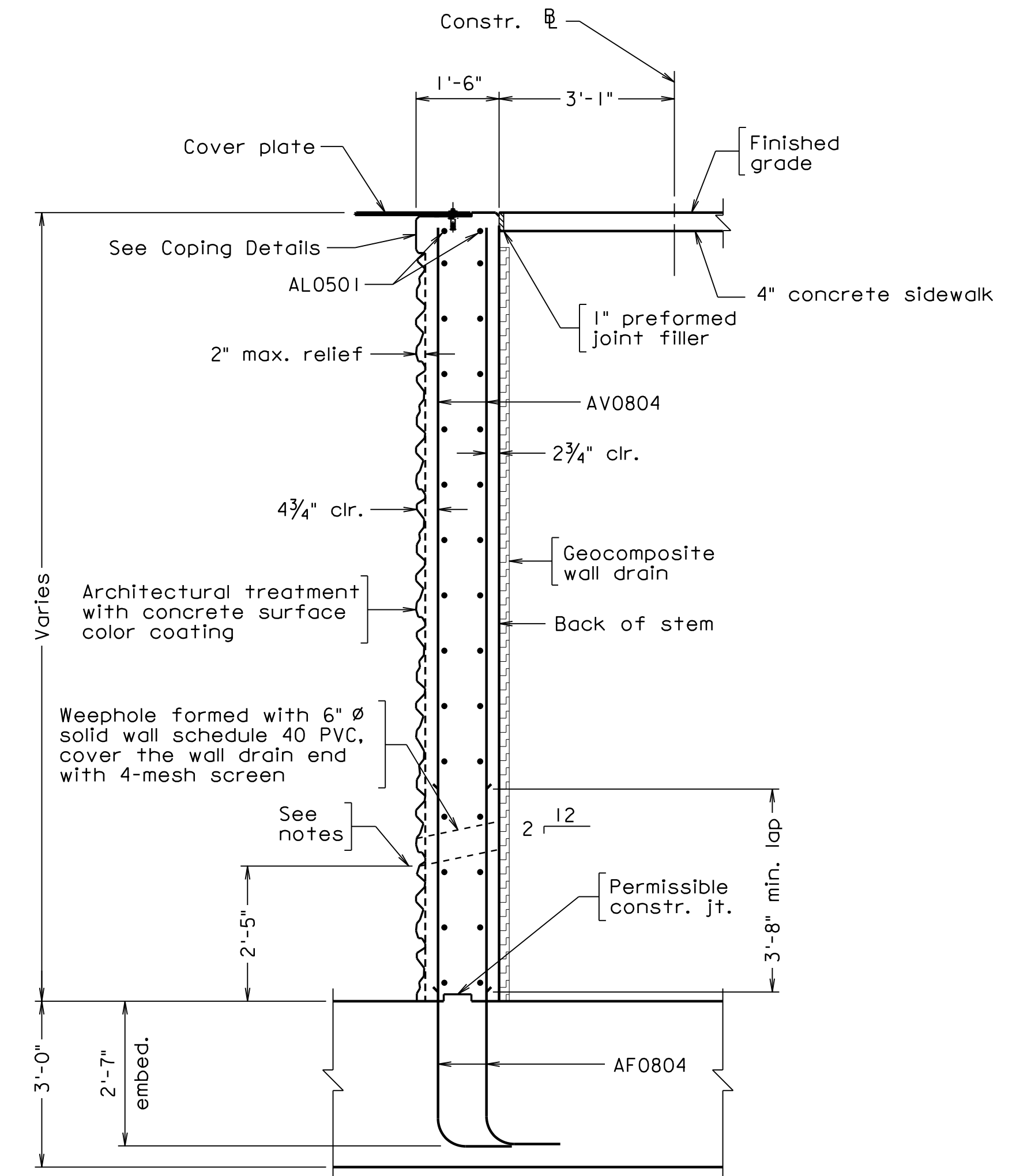

VIEW C
33/34

300-46_34.dgn

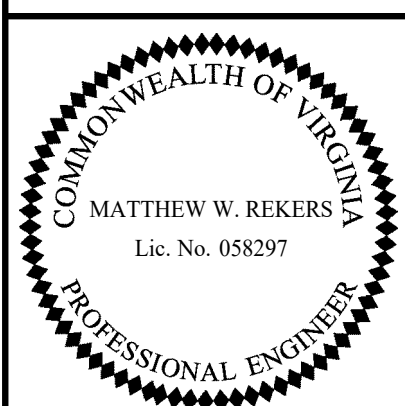

TRANSYSTEMS
RICHMOND, VA
STRUCTURAL ENGINEER

Scale: 3/8" = 1'-0" unless otherwise noted

© 2023, Commonwealth of Virginia

COMMONWEALTH OF VIRGINIA DEPARTMENT OF TRANSPORTATION					
STRUCTURE AND BRIDGE DIVISION					
ABUTMENT B RETAINING WALL I (2 OF 2)					
No.	Description	Date	Designed: V.A.J.	Date	Plan No.
			Drawn: L.B.W.	Apr. 2023	300-46
			Checked: M.W.R.		34 of 42
Revisions					

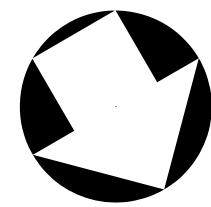

STATE	FEDERAL AID	STATE	SHEET
ROUTE	PROJECT	ROUTE	PROJECT
VA.		311	0311-080-913, B618
			35

Notes:

Place reinforcing to avoid weephole. 6" Ø hole centered on the weephole shall be cut in the plastic portion of the wall drain to connect it with the weephole.

Bottom of footing elevation shall not be lowered by more than one (1) foot.

For Handrail Anchor Bolt Details and Weephole Reinforcement Details, see sheet 13.

For Abutment B Reinforcement Schedule, see sheet 26.

For Footing Plan, see Sheet 36.

For Architectural Treatment and Coping Details, see sheet 39.

See VDOT Road and Bridge Standard HR-1 (Page 601.05) for HR-1 Type II Handrail details. Handrails shall be painted brown.

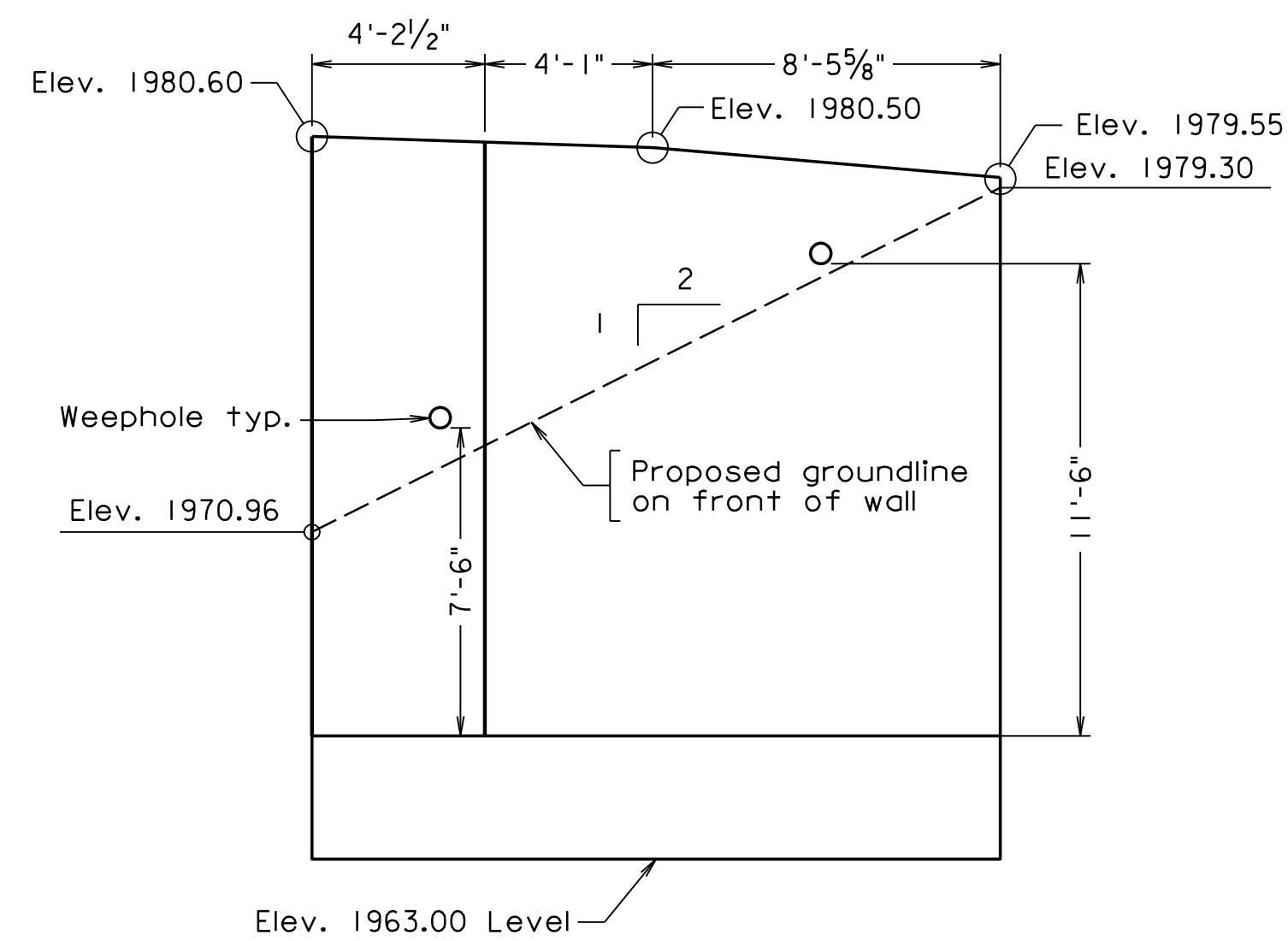
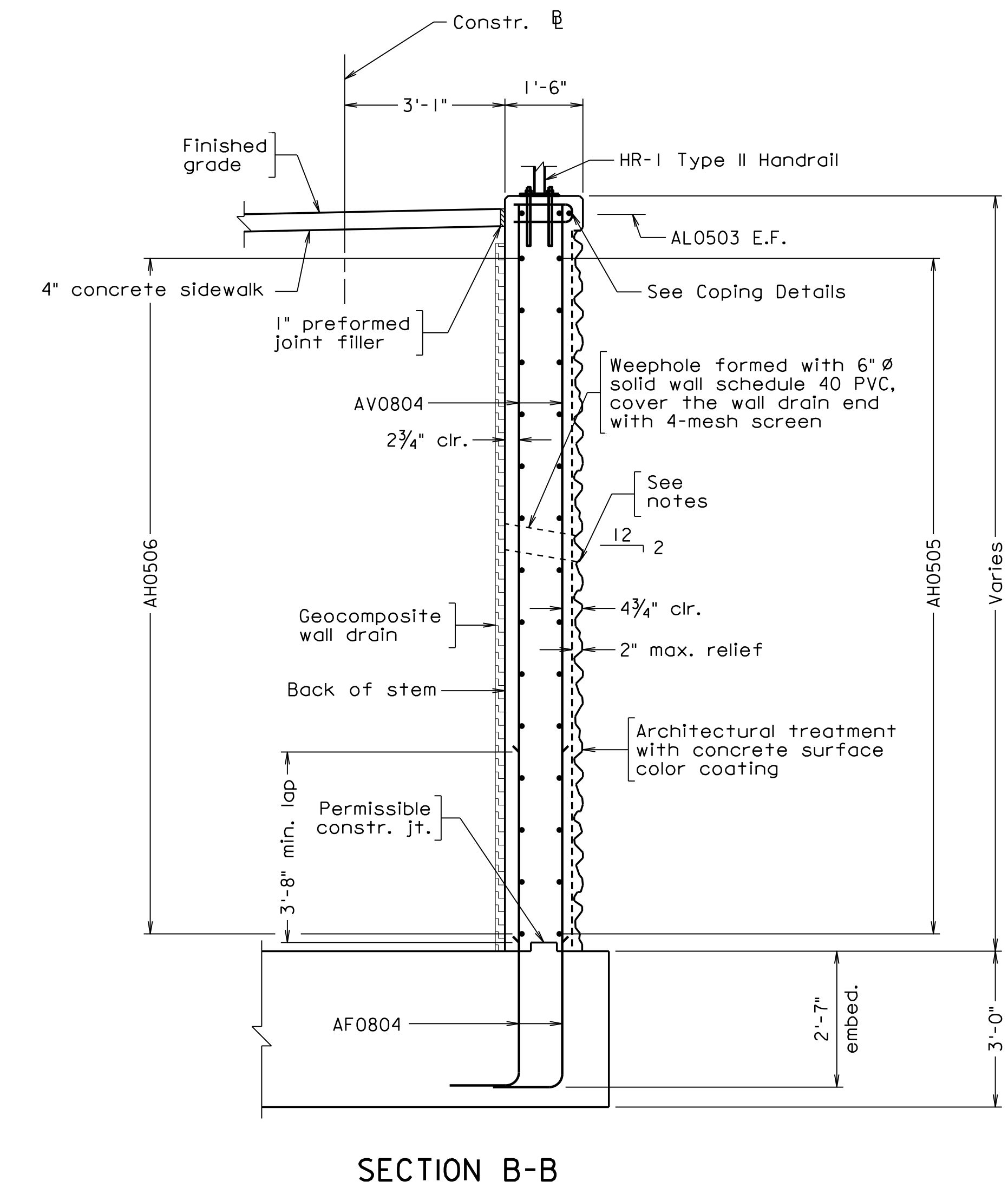
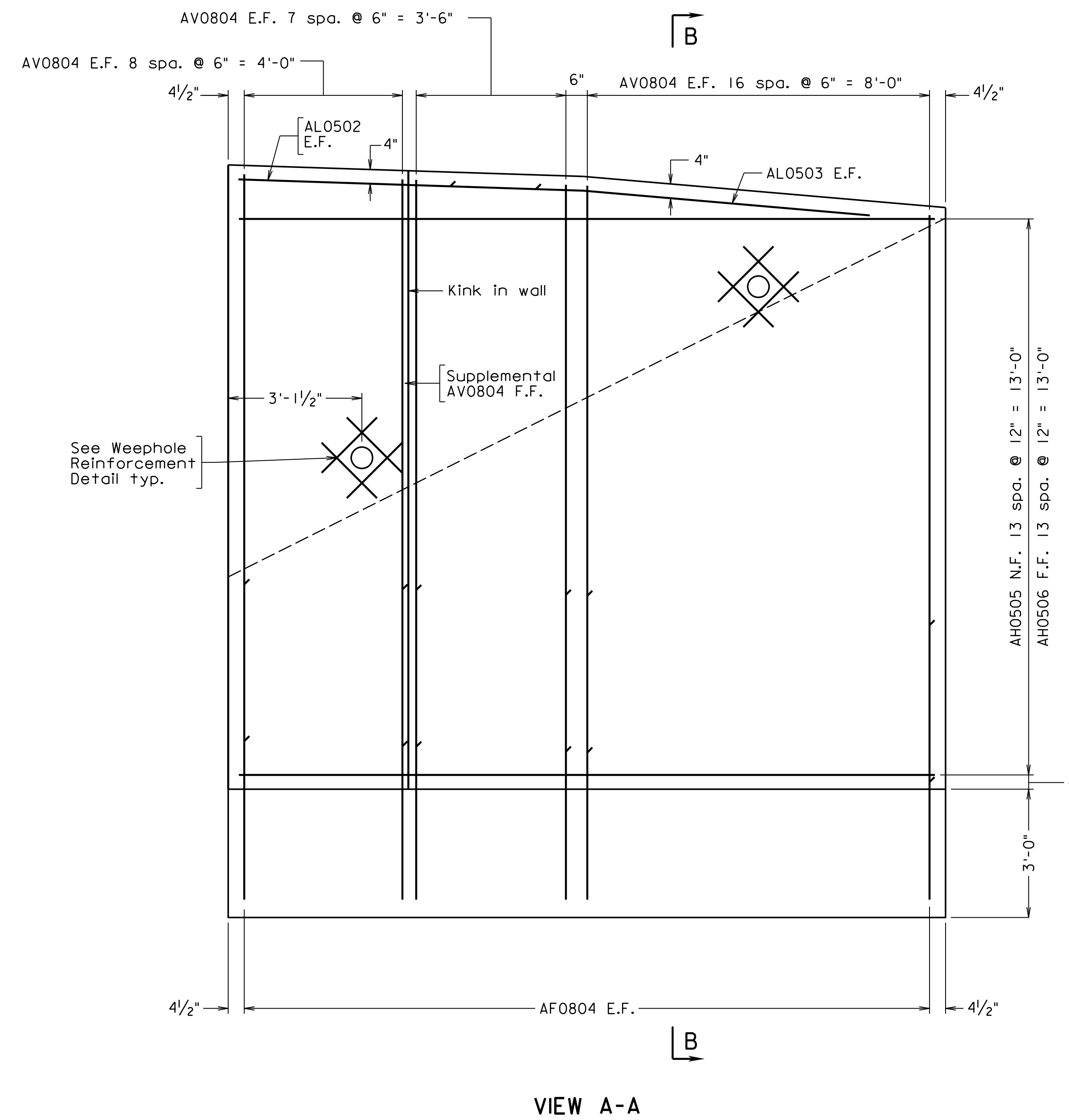
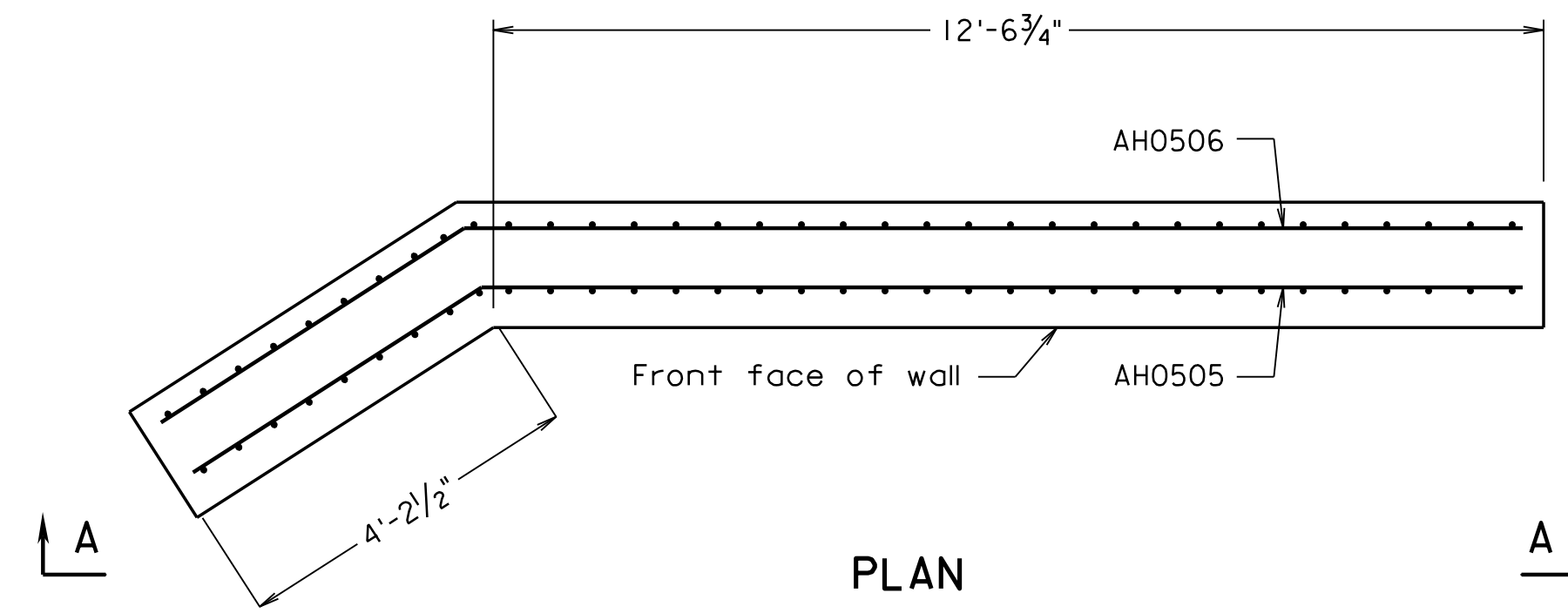

ABUTMENT B RETAINING WALL 2 GEOMETRY
Scale: 1/4" = 1'-0"

VIEW A-A

Scale: 1/2" = 1'-0" unless otherwise noted

© 2023, Commonwealth of Virginia

COMMONWEALTH OF VIRGINIA DEPARTMENT OF TRANSPORTATION STRUCTURE AND BRIDGE DIVISION					
ABUTMENT B RETAINING WALL 2					
No.	Description	Date	Designed: V.A.J./... Drawn: I.B.W./... Checked: M.W.B./...	Date	Plan No.
	Revisions			Apr. 2023	300-46
					35 of 42

300-46-35.dgn

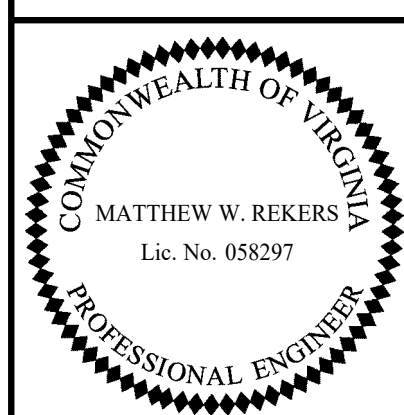

TRANSYSTEMS
RICHMOND, VA
STRUCTURAL ENGINEER

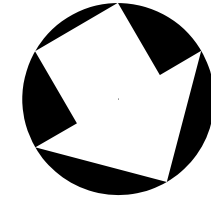

STATE	FEDERAL AID	STATE	SHEET
ROUTE	PROJECT	ROUTE	NO.
VA.		311	36
		0311-080-913, B618	

Notes:
 For metal stair concrete pilaster details and metal stair concrete footing details, see sheet 41.

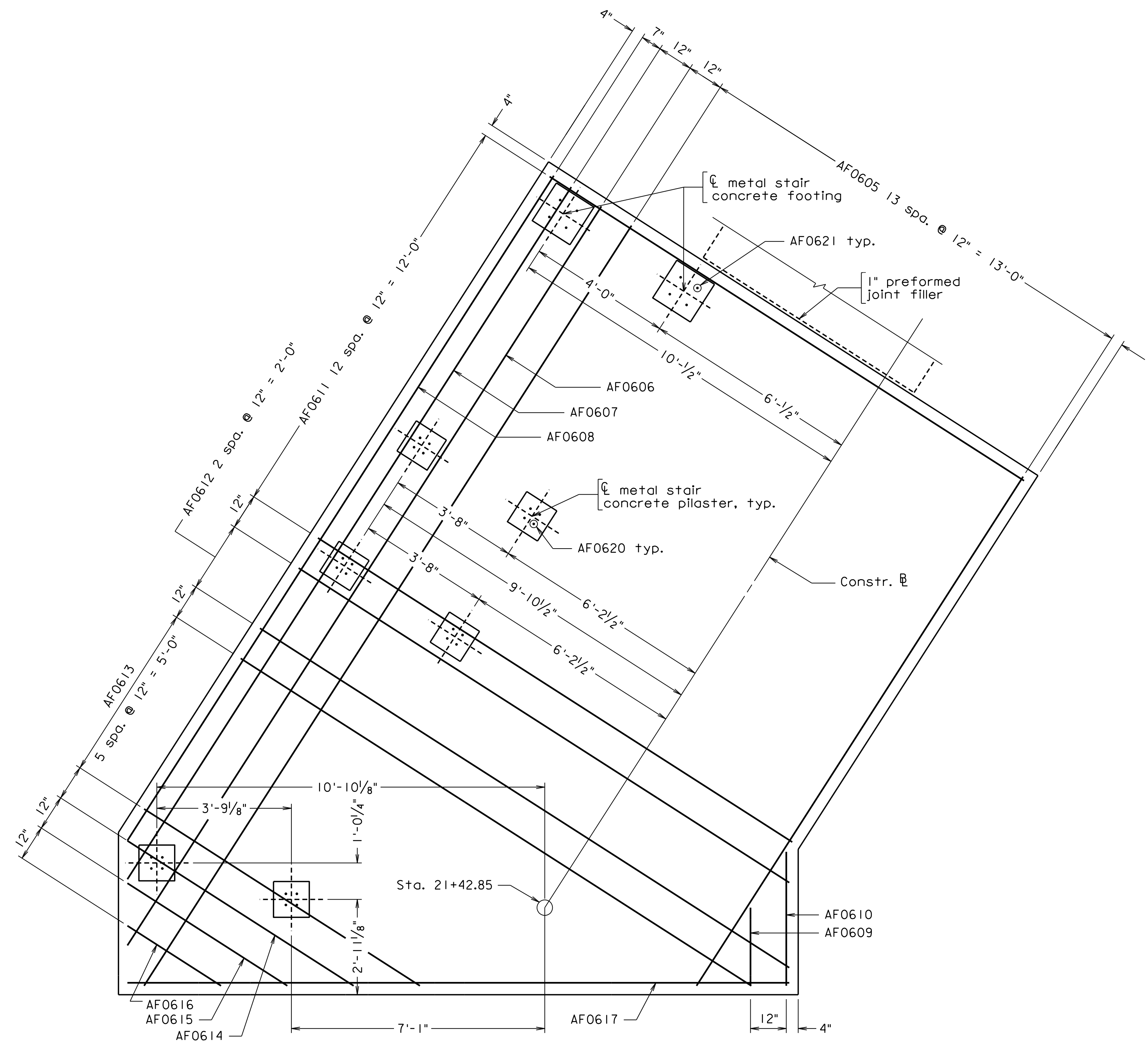

FOOTING PLAN

Top reinforcing shown, bottom similar

300-46_36.dgn

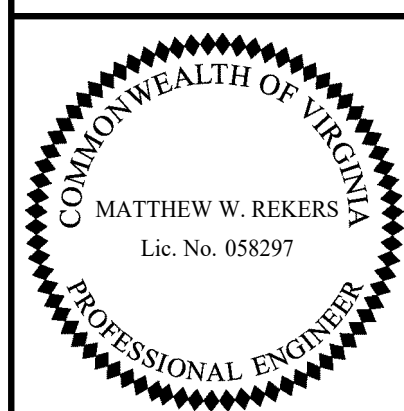

TRANSYSTEMS
 RICHMOND, VA
 STRUCTURAL ENGINEER

Scale: 1/2" = 1'-0" unless otherwise noted

© 2023, Commonwealth of Virginia

COMMONWEALTH OF VIRGINIA DEPARTMENT OF TRANSPORTATION					
STRUCTURE AND BRIDGE DIVISION					
ABUTMENT B RETAINING WALLS 1 AND 2 FOOTING					
No.	Description	Date	Designed: V.A.J.	Date	Plan No.
			Drawn: J.B.W.	Apr. 2023	300-46
			Checked: M.W.R.		36 of 42
Revisions					

STATE	FEDERAL AID	STATE	SHEET
ROUTE	PROJECT	ROUTE	PROJECT
VA.		311	0311-080-913, B618
			37

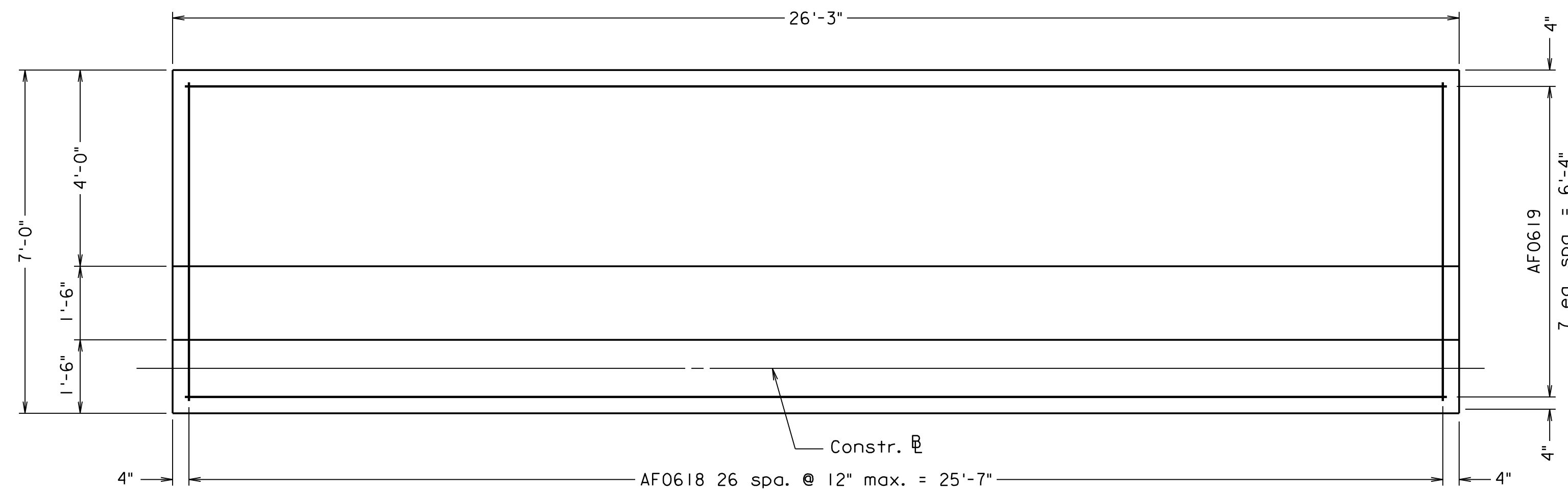
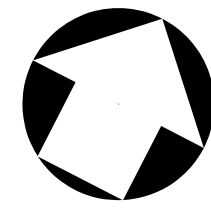

FOOTING PLAN
Top reinforcing shown, bottom similar

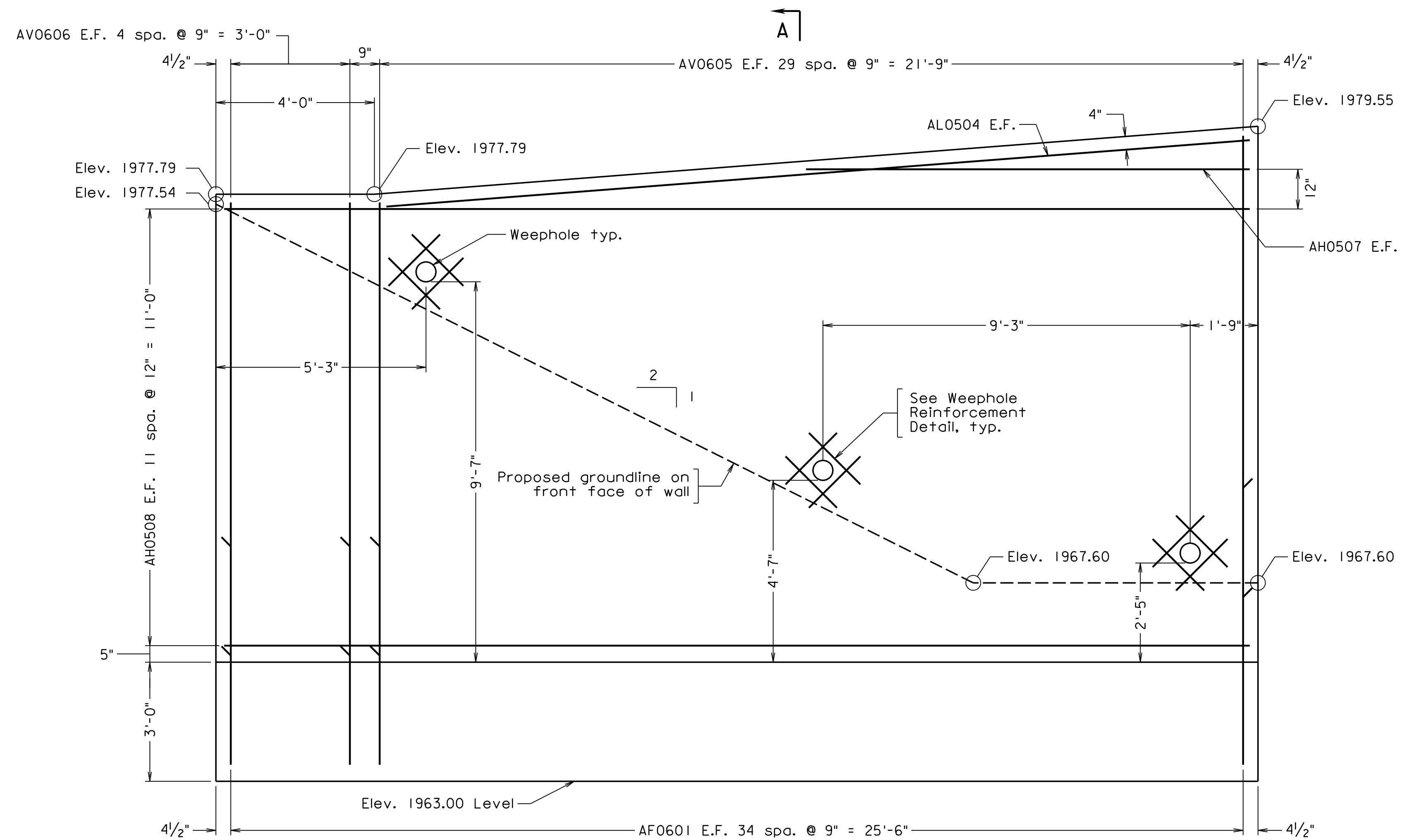

ELEVATION

Note:
Place reinforcing to avoid weephole. 6" \emptyset hole centered on the weephole shall be cut in the plastic portion of the wall drain to connect it with the weephole.
Bottom of footing elevation shall not be lowered by more than one (1) foot.
For Weephole Reinforcement Detail and Handrail Anchor Bolt Details, see sheet 13.
For Abutment B Reinforcement Schedule, see sheet 26.
Install weepholes at the lowest point feasible for free drainage away from abutment. Place reinforcing to avoid weephole.
Cost of joint filler shall be included in the price for substructure concrete.
For Architectural Treatment and Coping Details, see sheet 39.
See VDOT Road and Bridge Standard HR-1 (Page 601.05) for HR-1 Type II Handrail details. Handrails shall be painted brown.

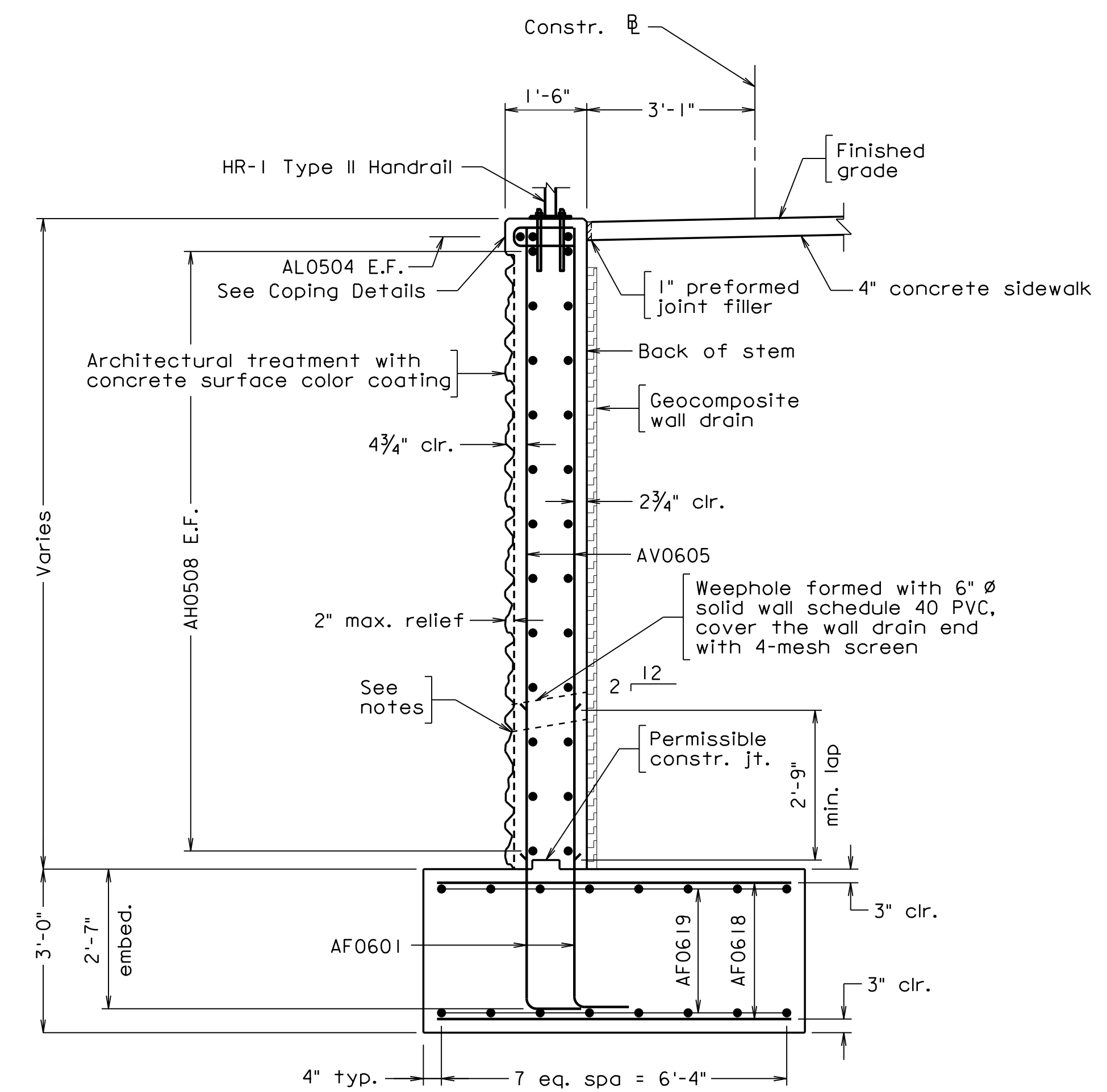

SECTION A-A

300-46.37.dgn

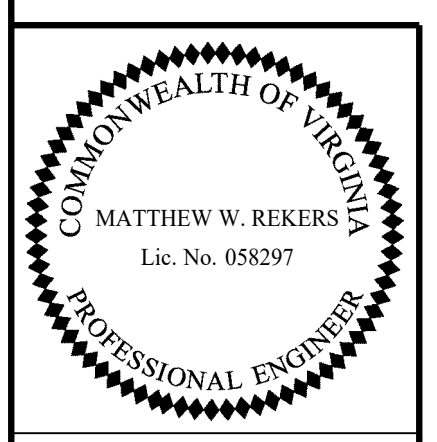

TRANSYSTEMS
RICHMOND, VA
STRUCTURAL ENGINEER

Scale: 1/2" = 1'-0" unless otherwise noted

© 2023, Commonwealth of Virginia

COMMONWEALTH OF VIRGINIA DEPARTMENT OF TRANSPORTATION STRUCTURE AND BRIDGE DIVISION					
ABUTMENT B RETAINING WALL 3					
No.	Description	Date	Designed: V.A.J.	Date	Plan No.
			Drawn: L.W.	Apr. 2023	300-46
			Checked: M.W.R.		37 of 42
Revisions					

STATE	FEDERAL AID	STATE	SHEET
ROUTE	PROJECT	ROUTE	PROJECT
VA.		311	0311-080-913, B618
			38

Notes:

Form liner shall be arranged to produce a continuous drystack pattern without obvious repetition of the pattern.

Form liner pattern shall be inspected and approved by the Department.

Contractor shall submit shop drawings with pattern layout for approval by the Department.

A color coating of Dark Gray No. 595-36492 shall be applied to the full length of front face and top side of retaining walls.

For Abutment A Reinforcement Schedule, see sheet 25.

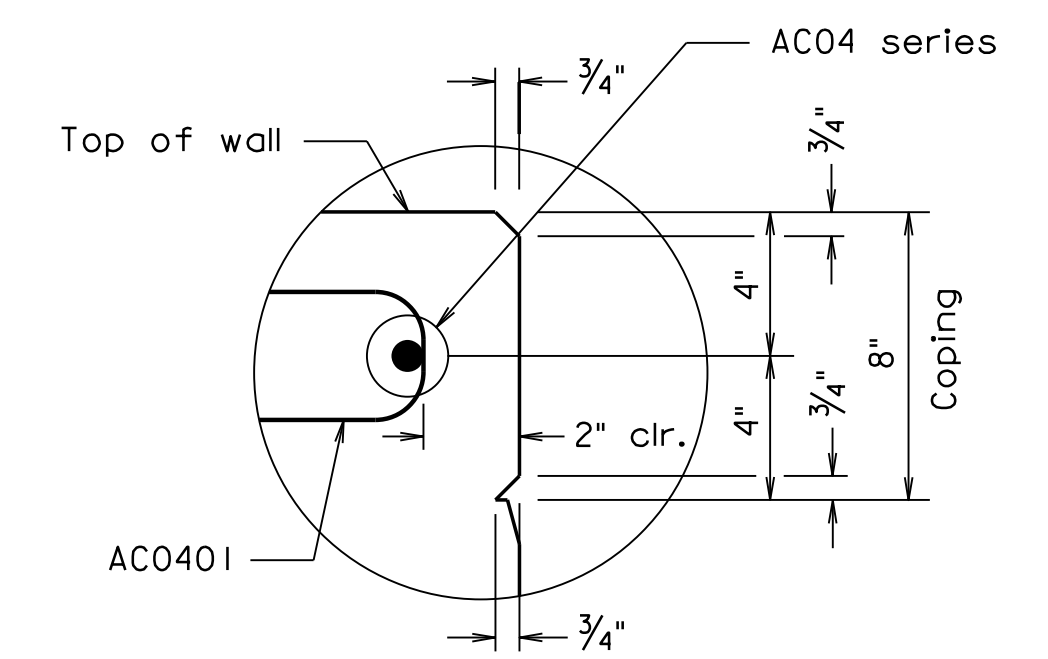
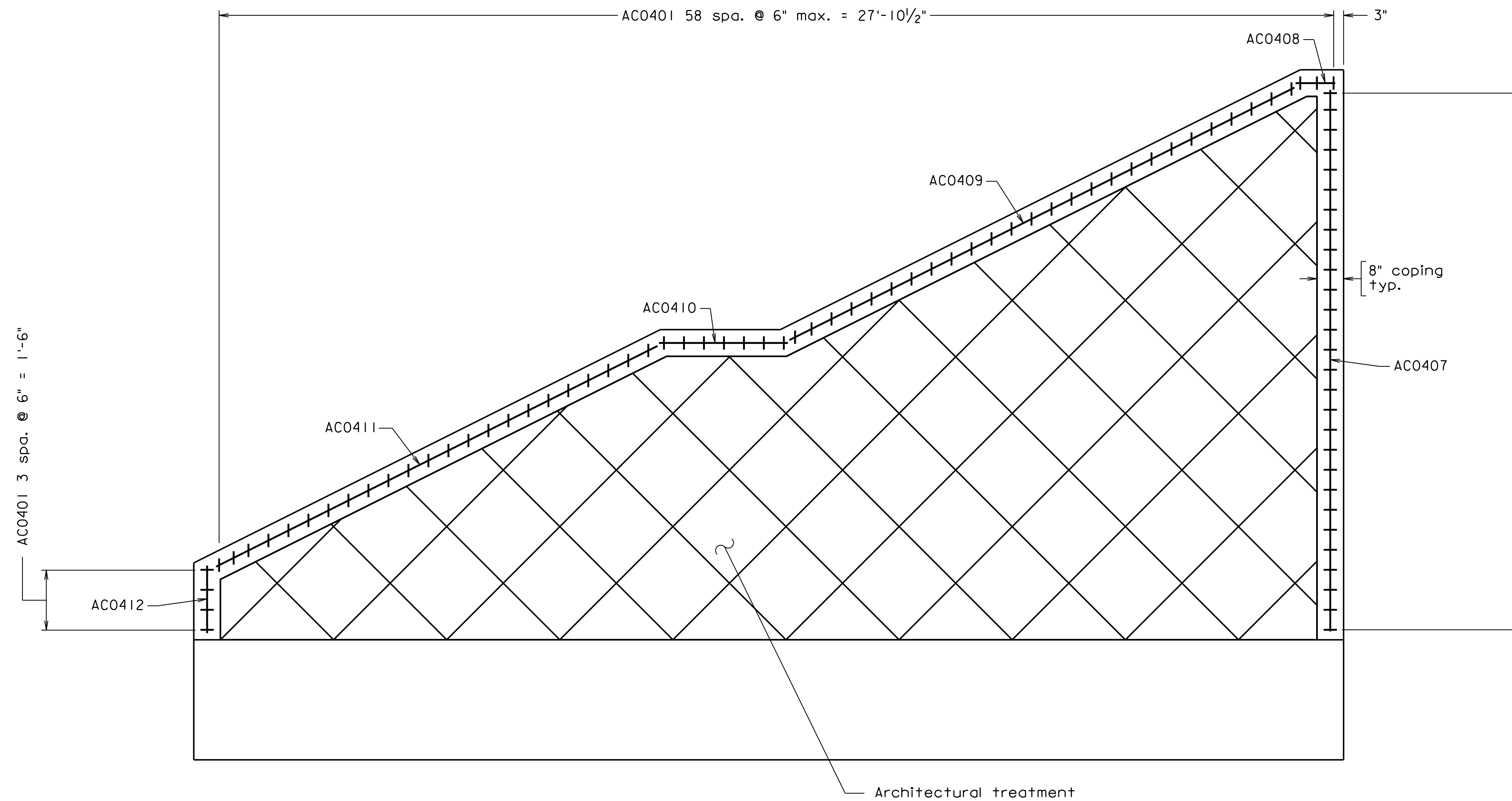

8" COPING DETAIL
Not to scale

**ABUTMENT A RETAINING WALLS
COPING AND ARCHITECTURAL TREATMENT**

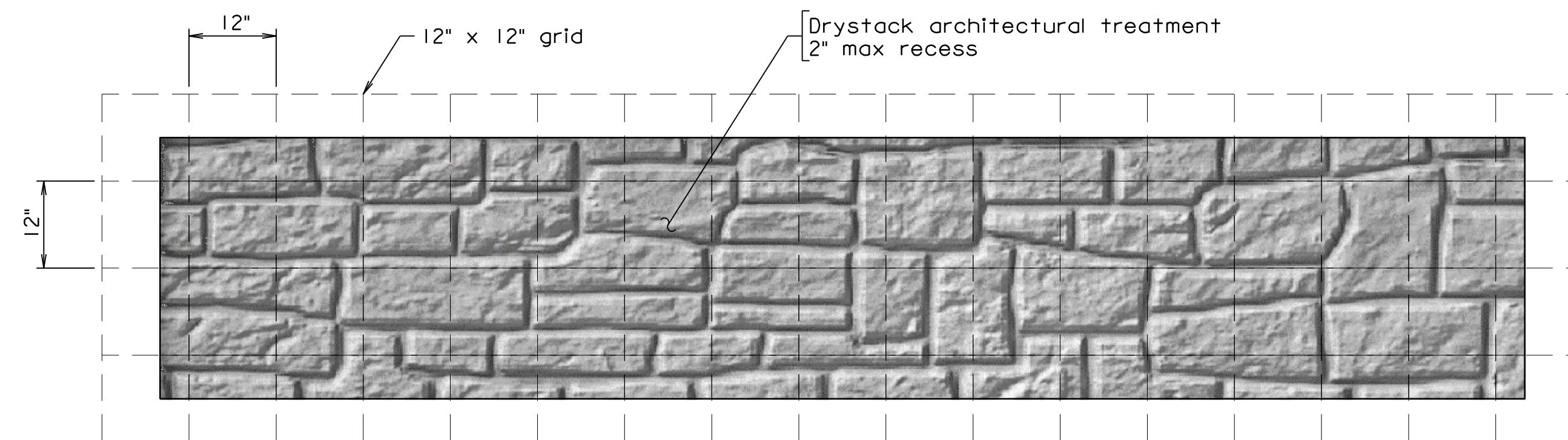

DRYSTACK TEXTURE DETAIL
Retaining Walls - Front Face

COMMONWEALTH OF VIRGINIA DEPARTMENT OF TRANSPORTATION					
STRUCTURE AND BRIDGE DIVISION					
ABUTMENT A RETAINING WALLS ARCHITECTURAL TREATMENT					
No.	Description	Date	Designed: S.N.....	Date	Plan No.
			Drawn: V.A.U.....	Apr. 2023	300-46
			Checked: M.W.R.....		38 of 42
Revisions					

Scale: 1/2" = 1'-0"

© 2023, Commonwealth of Virginia

300-46-38.dgn

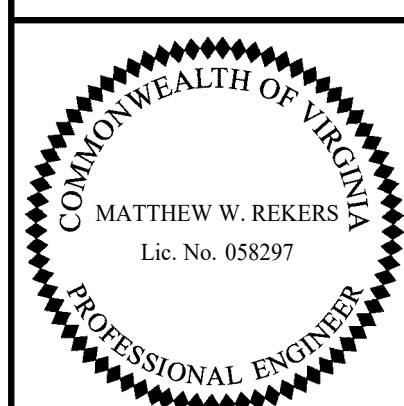

TRANSYSTEMS
RICHMOND, VA
STRUCTURAL ENGINEER

STATE	FEDERAL AID	STATE	SHEET
ROUTE	PROJECT	ROUTE	PROJECT
VA.		311	0311-080-913, B618
			39

Notes:

Form liner shall be arranged to produce a continuous drystack pattern without obvious repetition of the pattern.

Form liner pattern shall be inspected and approved by the Department.

Contractor shall submit shop drawings with pattern layout for approval by the Department.

A color coating of Dark Gray No. 595-36492 shall be applied to the full length of front face and top side of retaining walls.

For Abutment B Reinforcement Schedule, see sheet 26.

For Drystack Texture Detail, see Sheet 38.

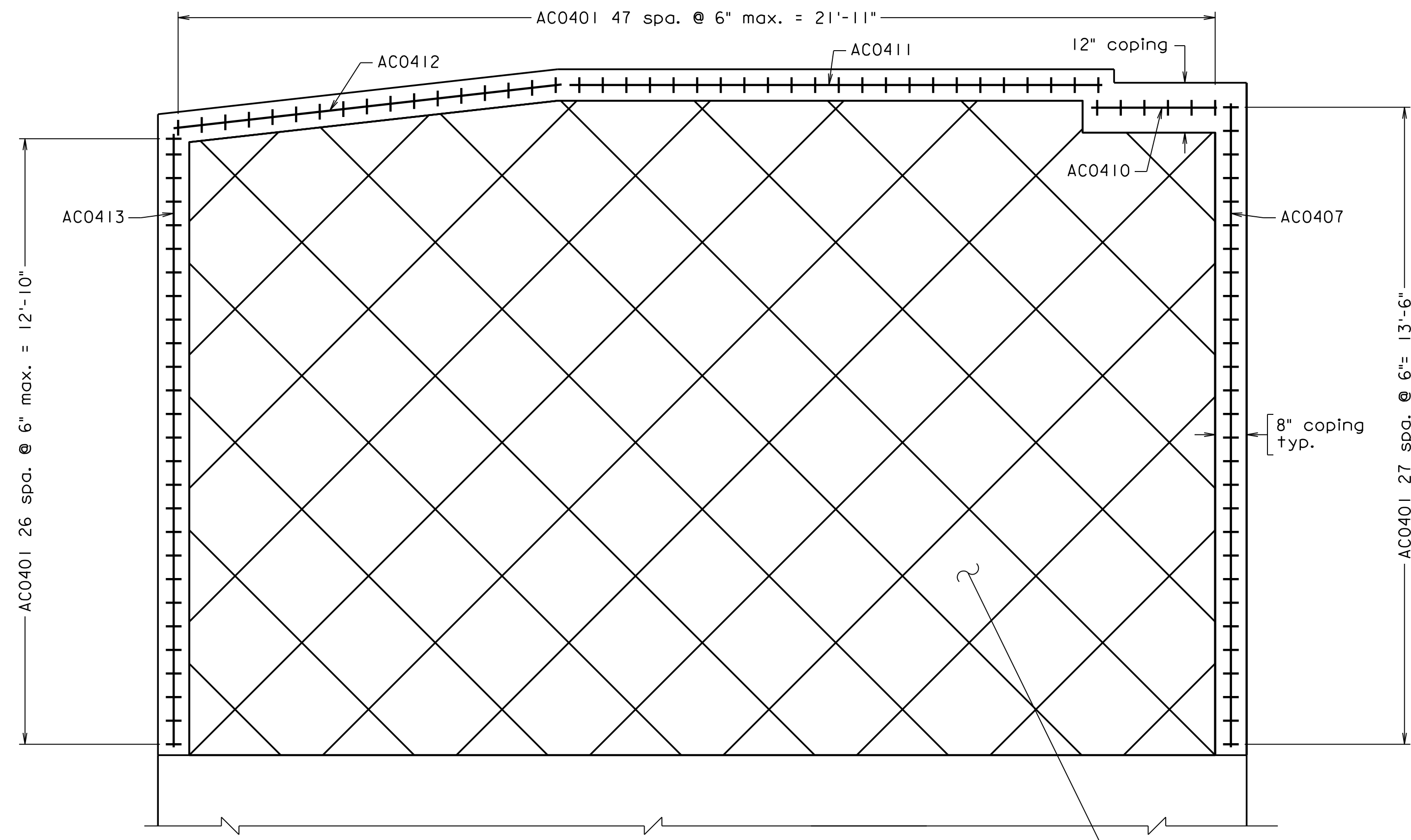

ABUTMENT B RETAINING WALL 1
COPING AND ARCHITECTURAL TREATMENT

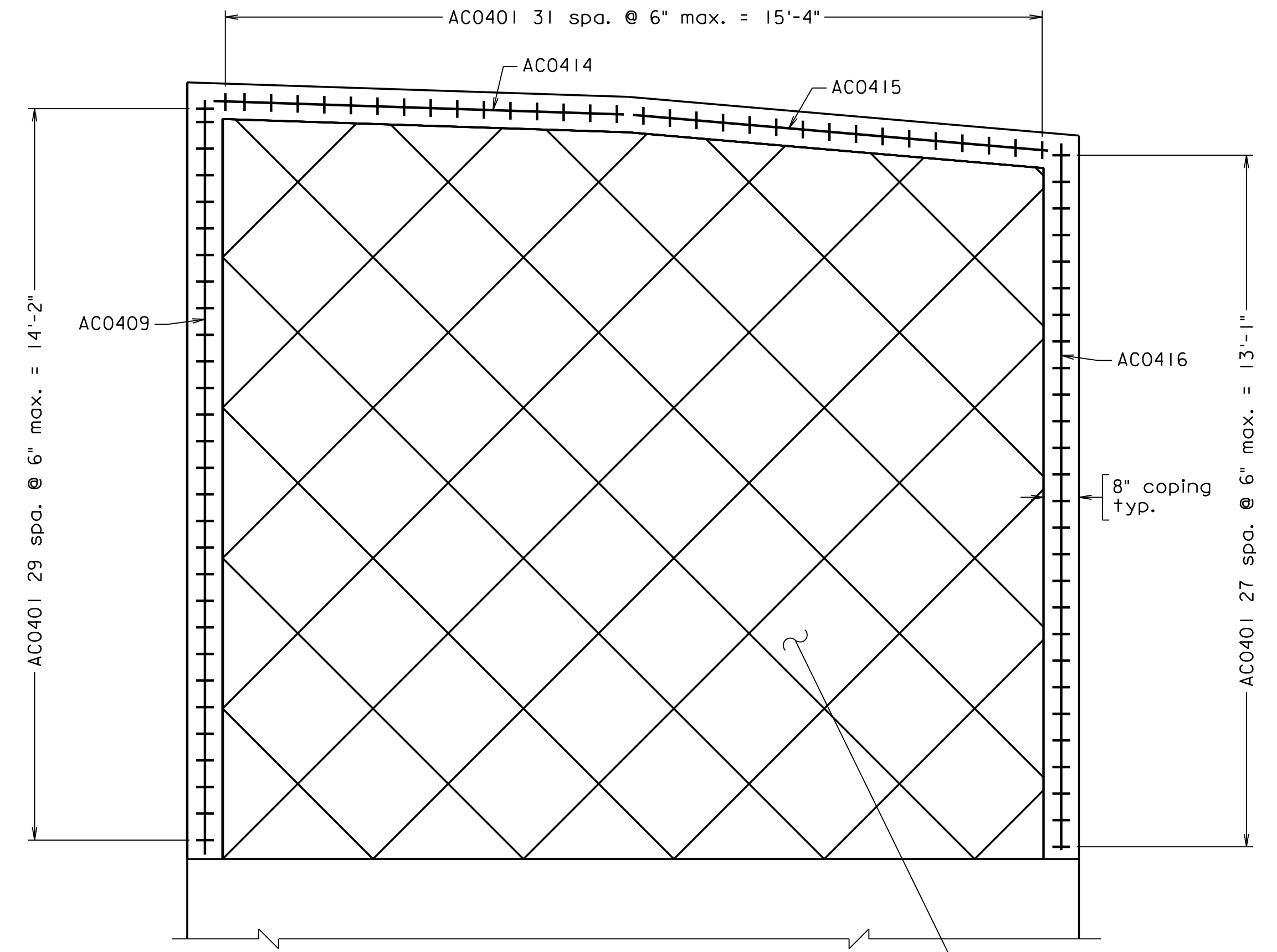

ABUTMENT B RETAINING WALL 2
COPING AND ARCHITECTURAL TREATMENT

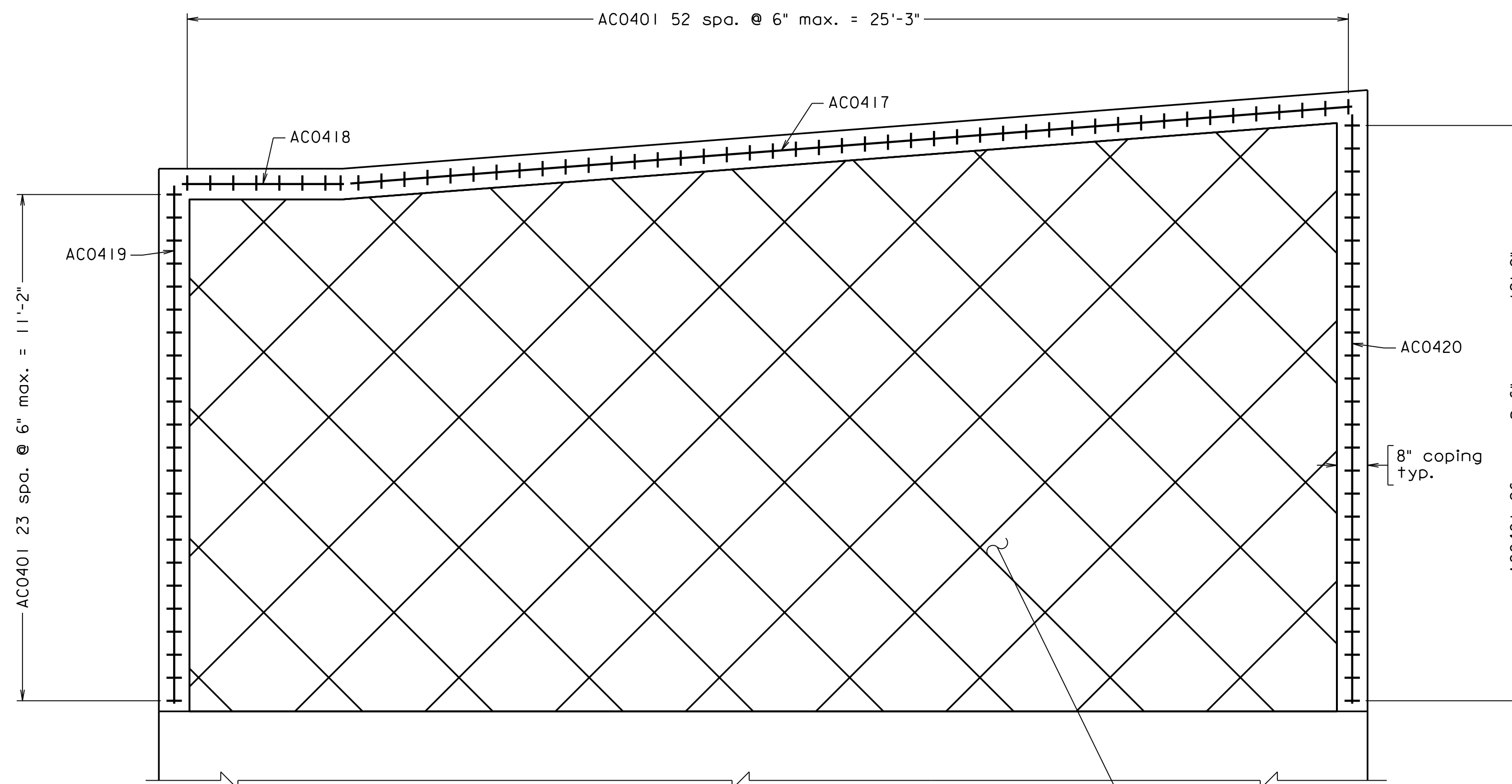

ABUTMENT B RETAINING WALL 3
COPING AND ARCHITECTURAL TREATMENT

300-46-39.dgn

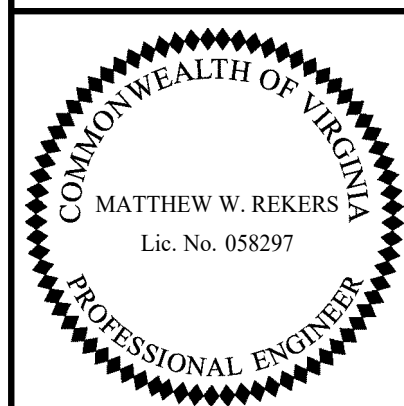

TRANSYSTEMS
RICHMOND, VA
STRUCTURAL ENGINEER

Scale: 1/2" = 1'-0"

© 2023, Commonwealth of Virginia

COMMONWEALTH OF VIRGINIA DEPARTMENT OF TRANSPORTATION					
STRUCTURE AND BRIDGE DIVISION					
ABUTMENT B RETAINING WALLS ARCHITECTURAL TREATMENT					
No.	Description	Date	Designed: S.N.	Date	Plan No.
			Drawn: V.A.U.	Apr. 2023	300-46
			Checked: M.W.R.		39 of 42
Revisions					

STATE	FEDERAL AID		STATE	SHEET
ROUTE	PROJECT		ROUTE	PROJECT
VA.			311	0311-080-913, B618
				40

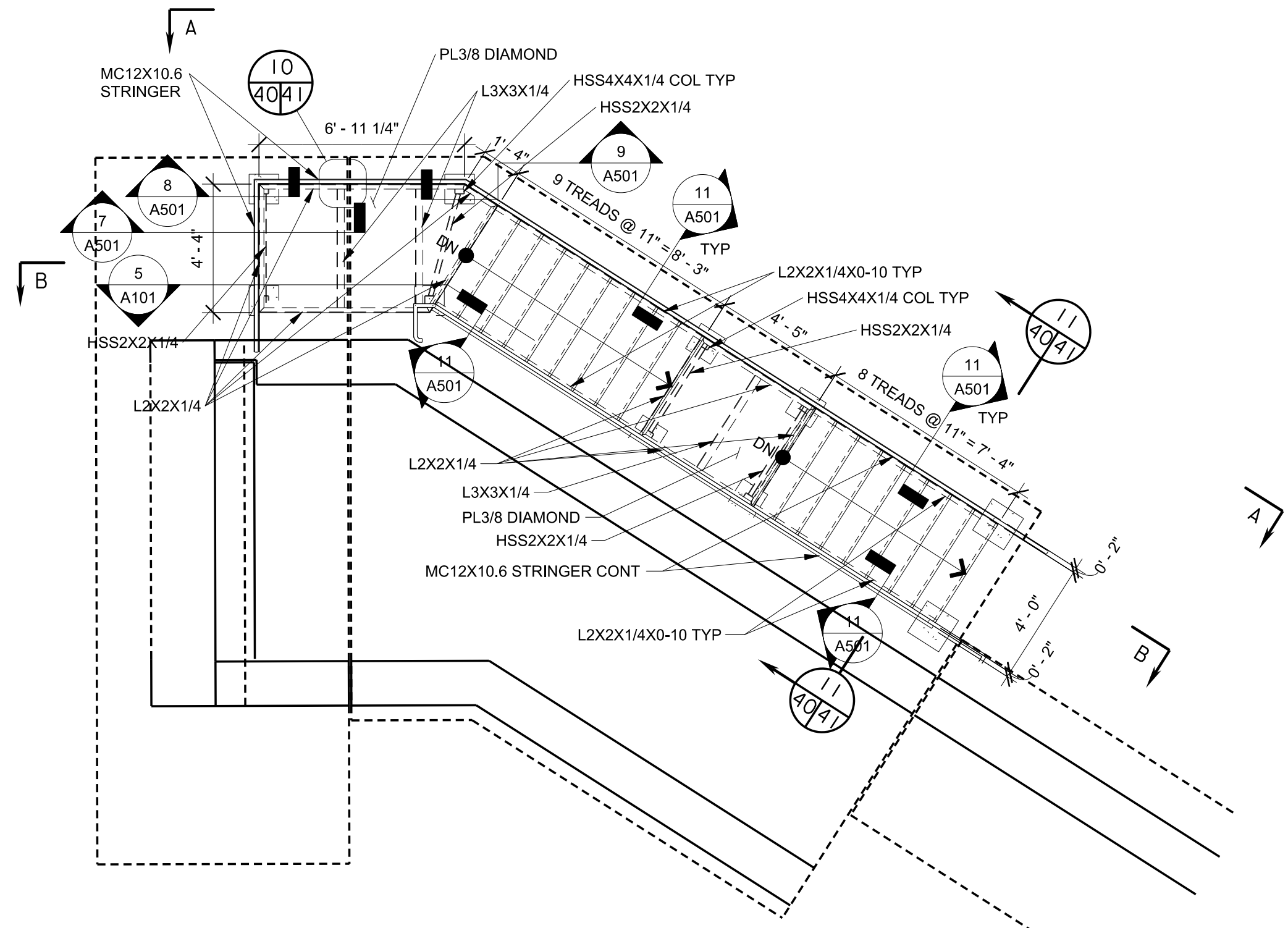

METAL STAIR PLAN
Scale: 1/4" = 1'-0"

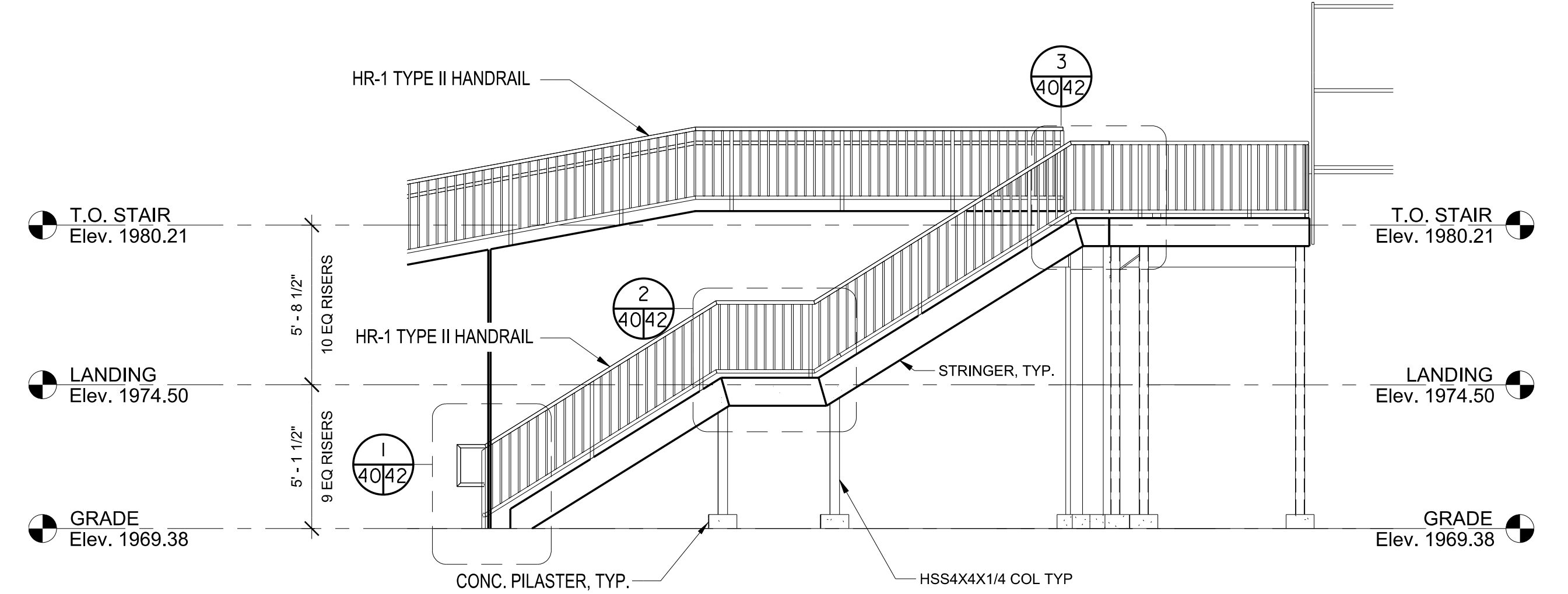

VIEW A-A
Scale: 1/4" = 1'-0"

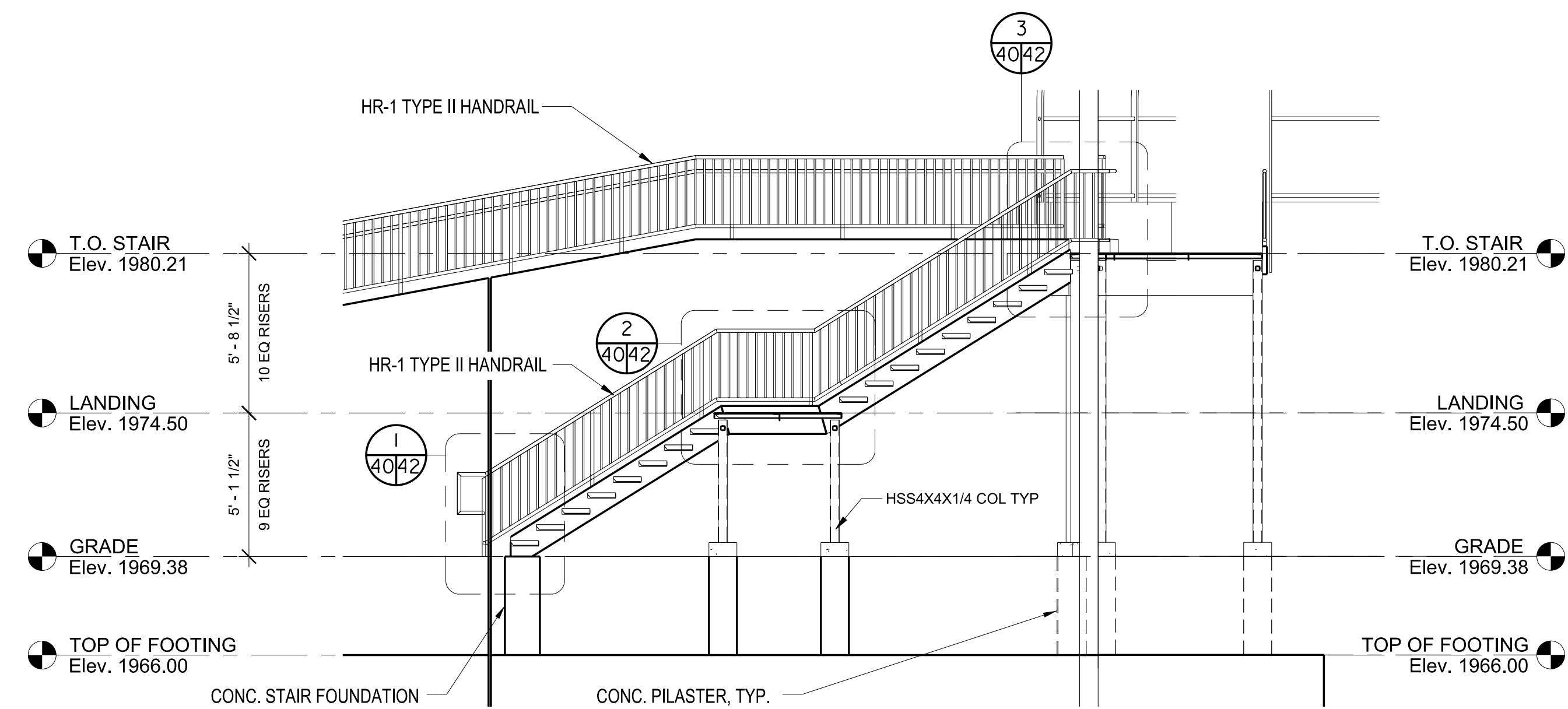

VIEW B-B
Scale: 1/4" = 1'-0"

Note:
All handrails and fencing to be grounded in accordance with VDOT Road and Bridge Standards FE-6 (Page 503.07).
See VDOT Road and Bridge Standard HR-1 (Page 601.05) for HR-1 Type I and Type II Handrail details. Handrails shall be painted brown.

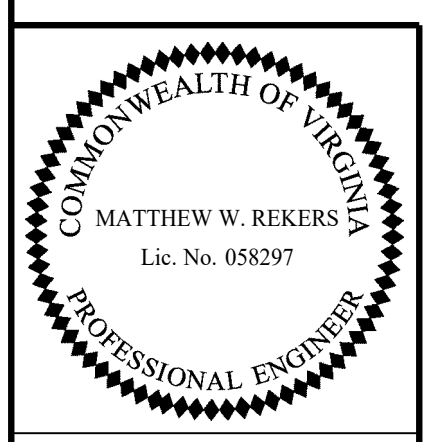

TRANSYSTEMS
RICHMOND, VA
STRUCTURAL ENGINEER

COMMONWEALTH OF VIRGINIA DEPARTMENT OF TRANSPORTATION STRUCTURE AND BRIDGE DIVISION					
METAL STAIR DETAILS (1 OF 3)					
No.	Description	Date	Designed: N.M.A. Drawn: N.M.A. Checked: G.B.E.	Date Apr. 2023	Plan No. 300-46
Revisions					Sheet No. 40 of 42

Scale: 1/4" = 1'-0" unless otherwise noted

© 2023, Commonwealth of Virginia

300-46-40.dgn

STATE	FEDERAL AID	STATE	SHEET
ROUTE	PROJECT	ROUTE	NO.
VA.		311	41
		0311-080-913, B618	

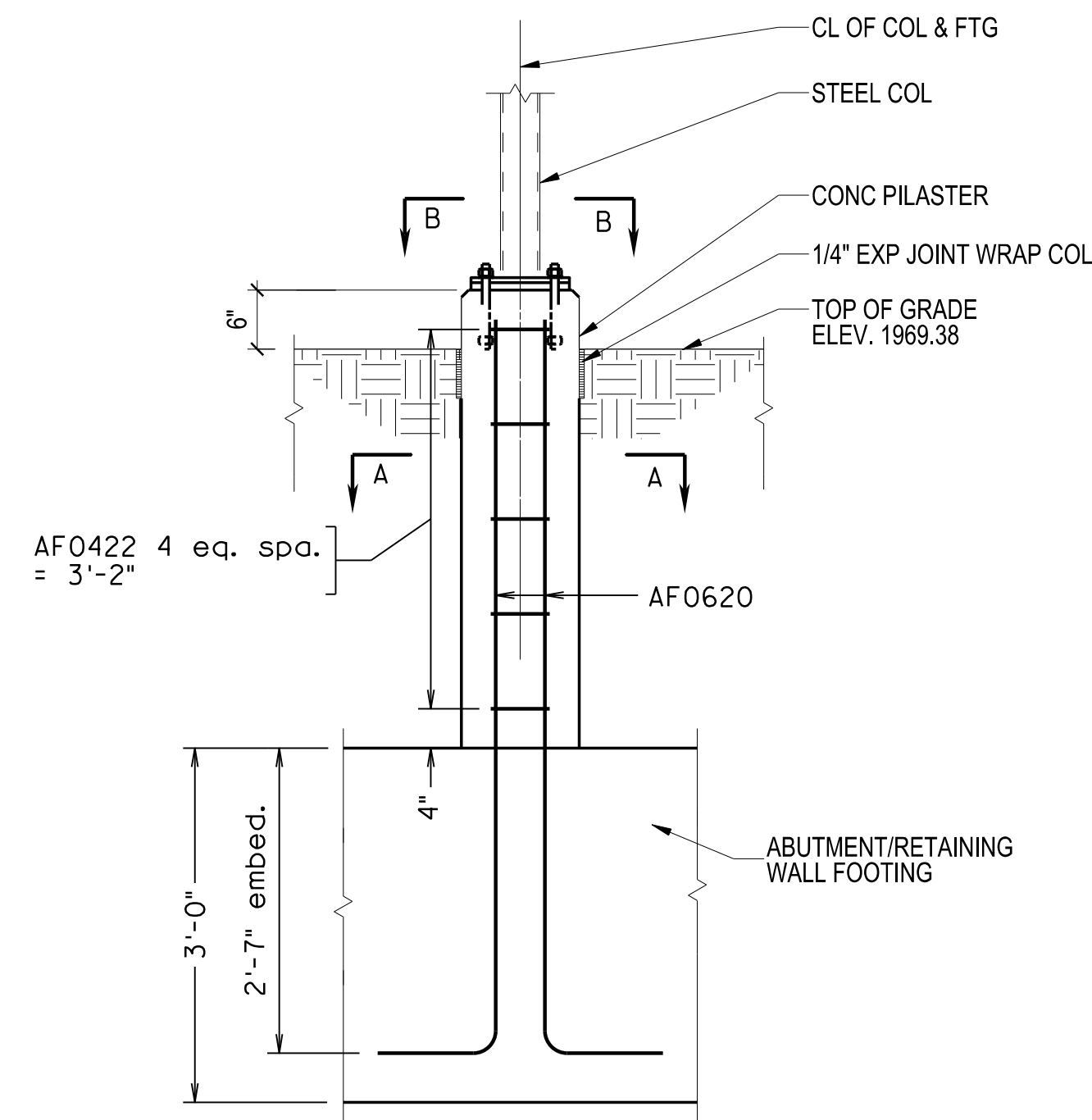

1 FOUNDATION PILASTER COLUMN
3/4" = 1'-0"

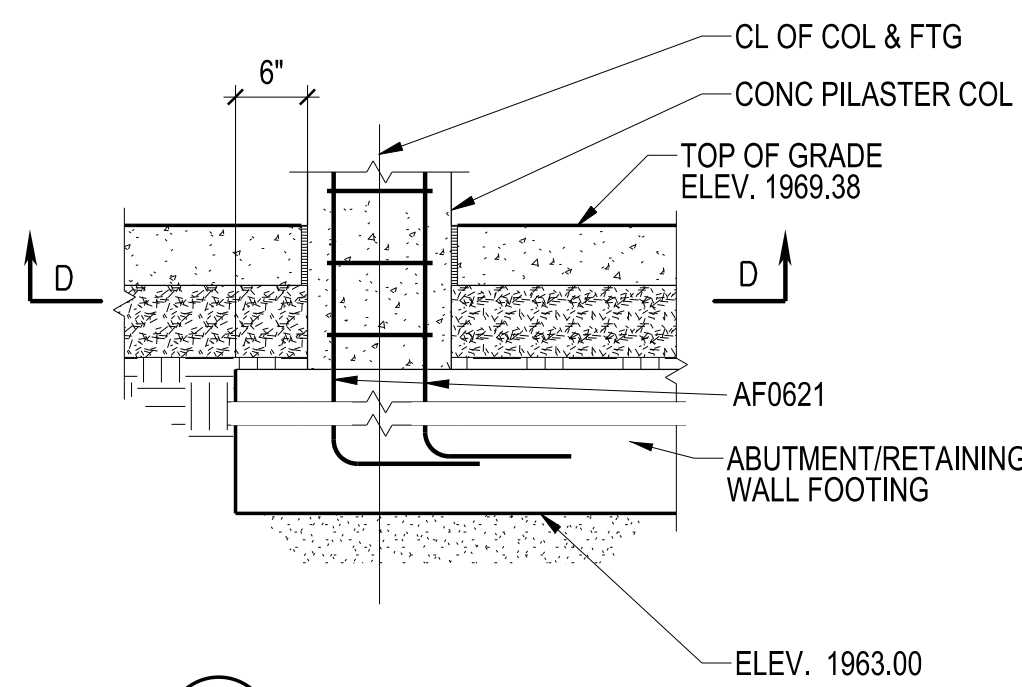

5 FOUNDATION PILASTER
3/4" = 1'-0"

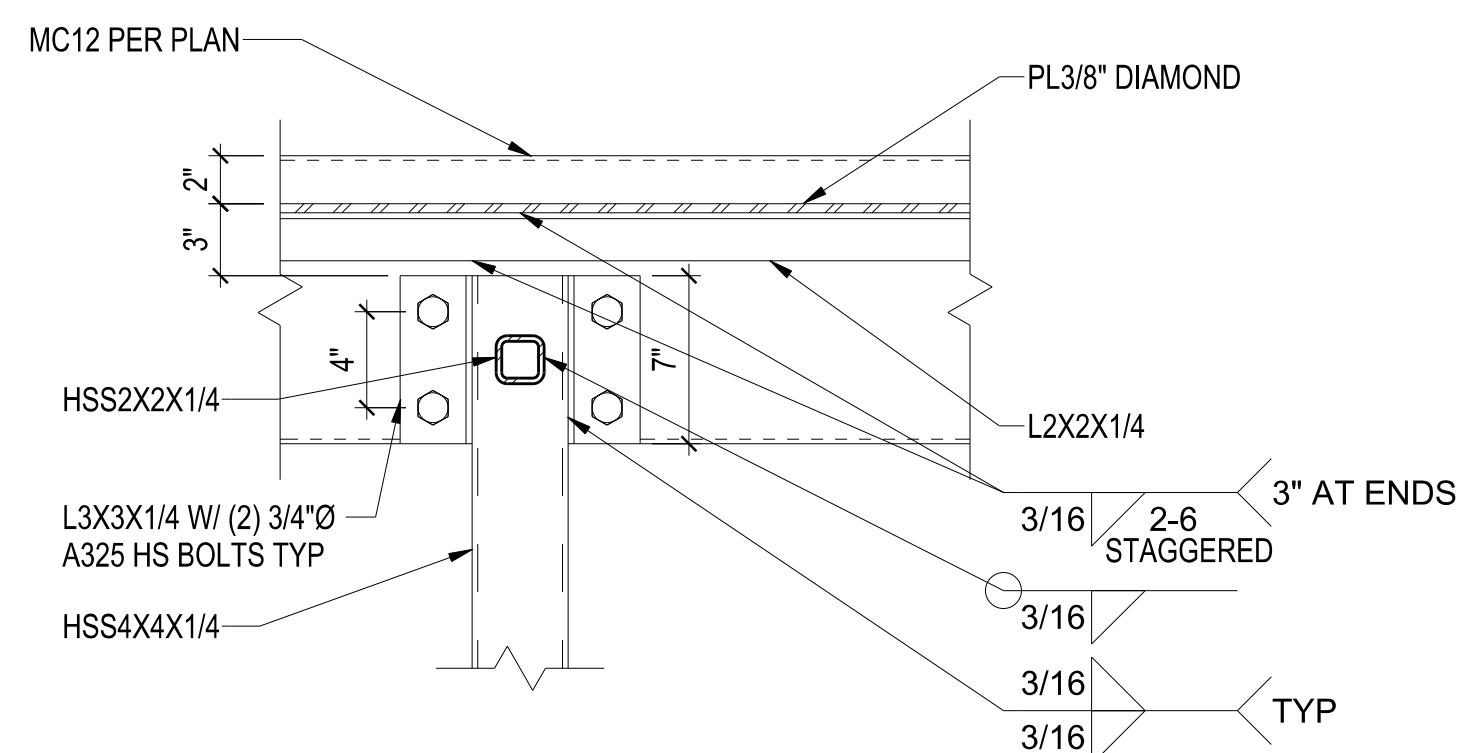

9 STAIR FRAMING DETAIL
1 1/2" = 1'-0"

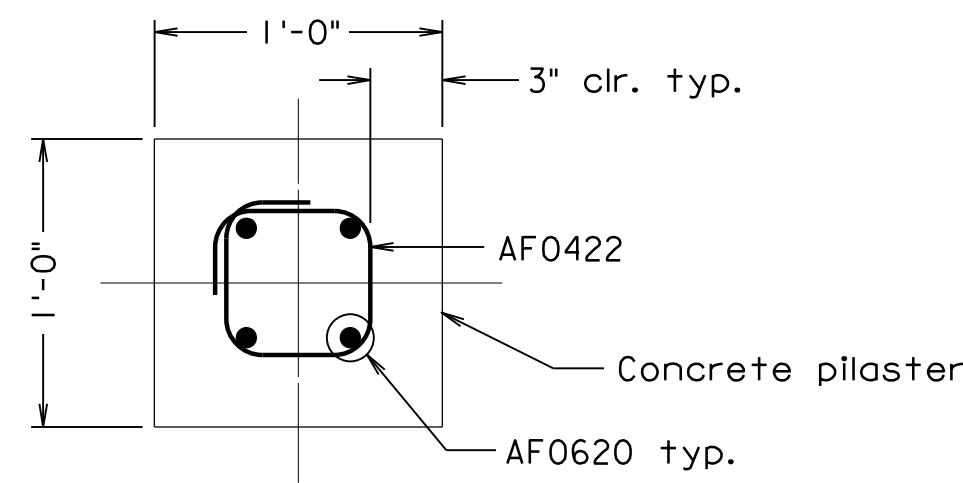

SECTION A-A - PILASTER SECTION
1 1/2" = 1'-0"

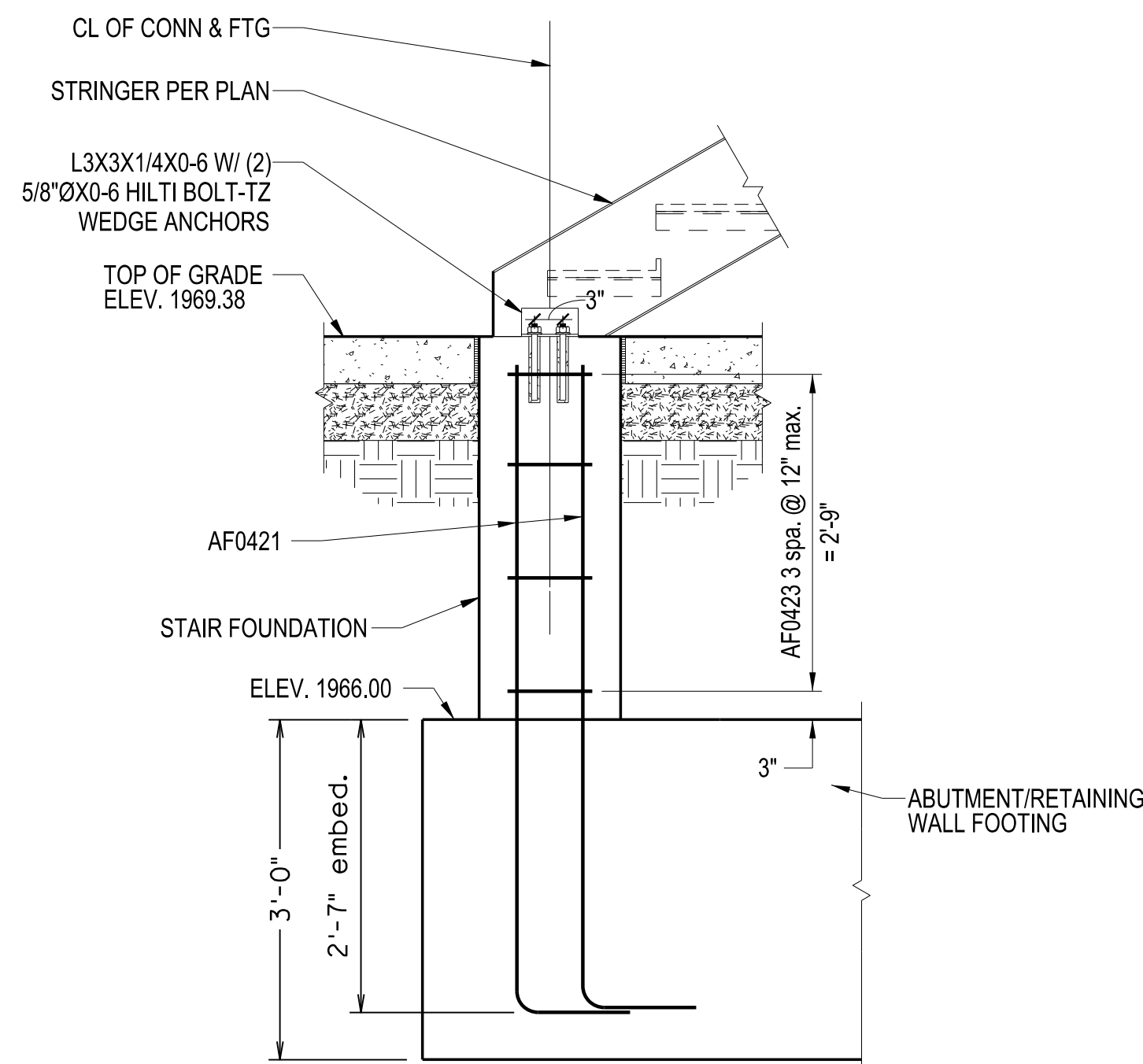

6 STAIR FOUNDATION
3/4" = 1'-0"

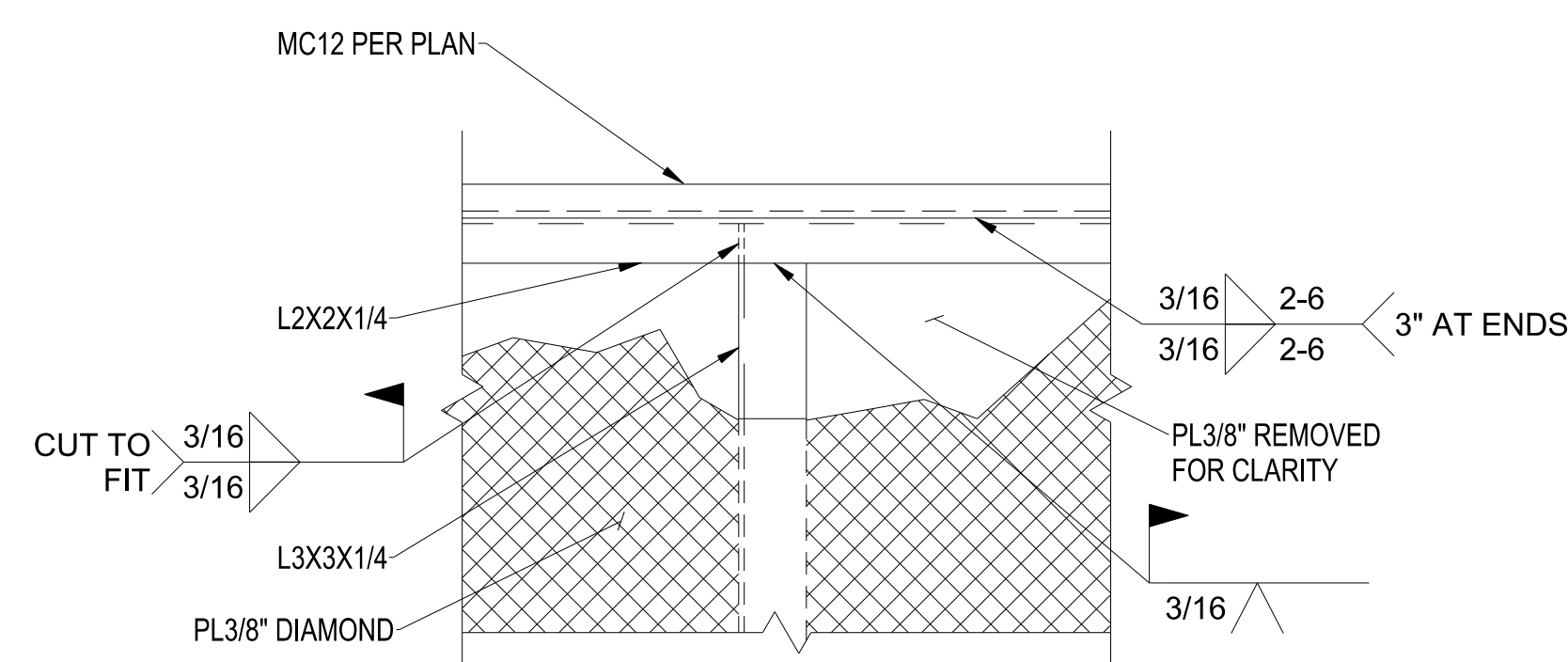

10 STAIR FRAMING DETAIL
1 1/2" = 1'-0"

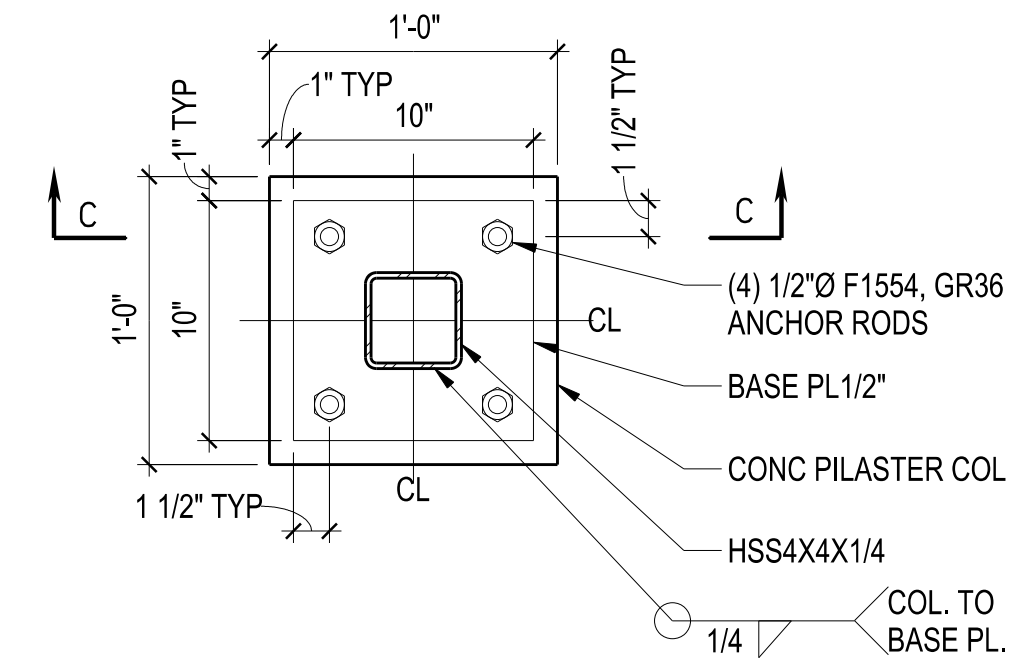

VIEW B-B - BASE PLATE HSS COL W/ ANCHOR RODS DETAIL
1 1/2" = 1'-0"

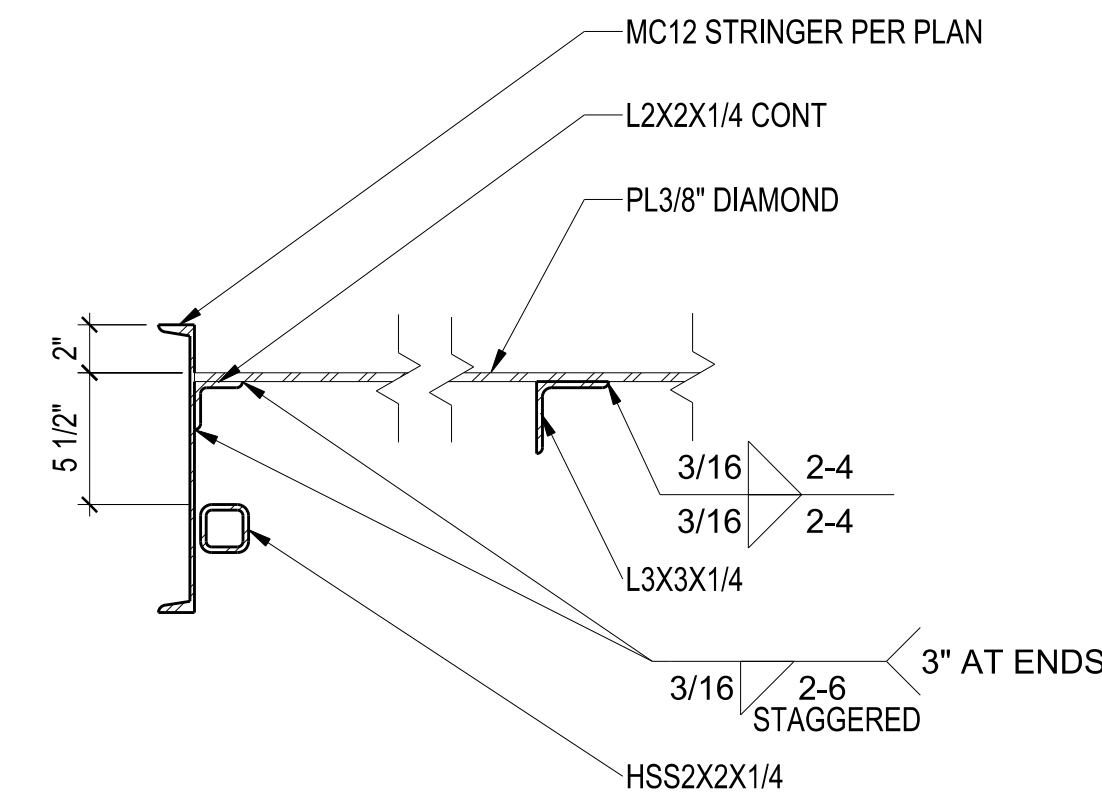

7 STAIR FRAMING DETAIL
1 1/2" = 1'-0"

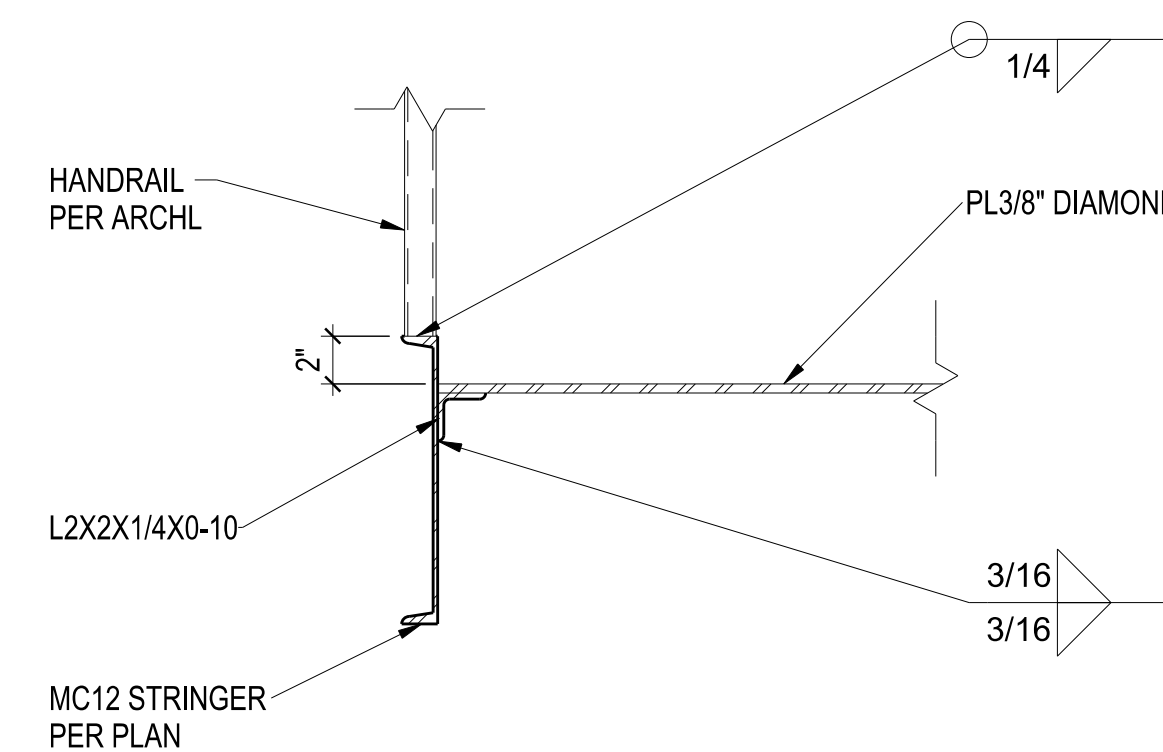

11 STAIR FRAMING DETAIL
1 1/2" = 1'-0"

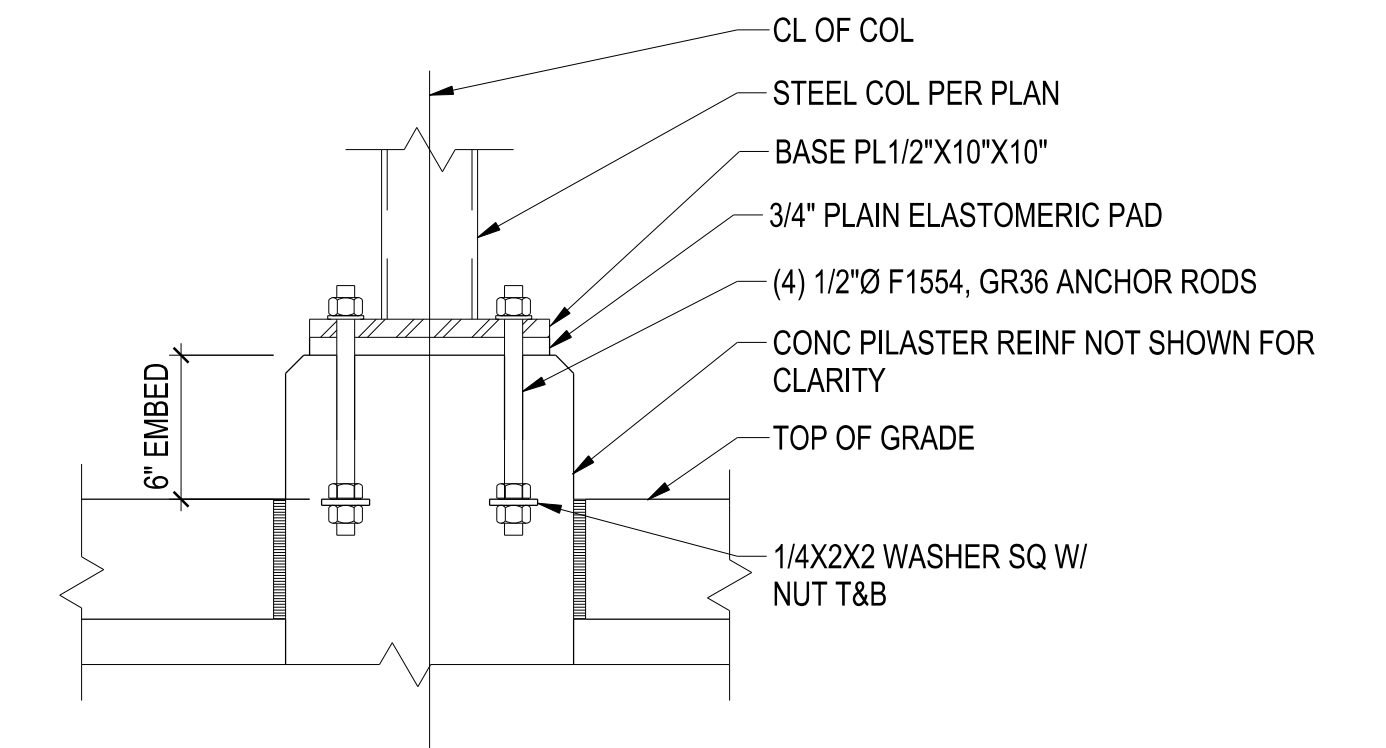

SECTION C-C - PILASTER COLUMN CONNECTION
1 1/2" = 1'-0"

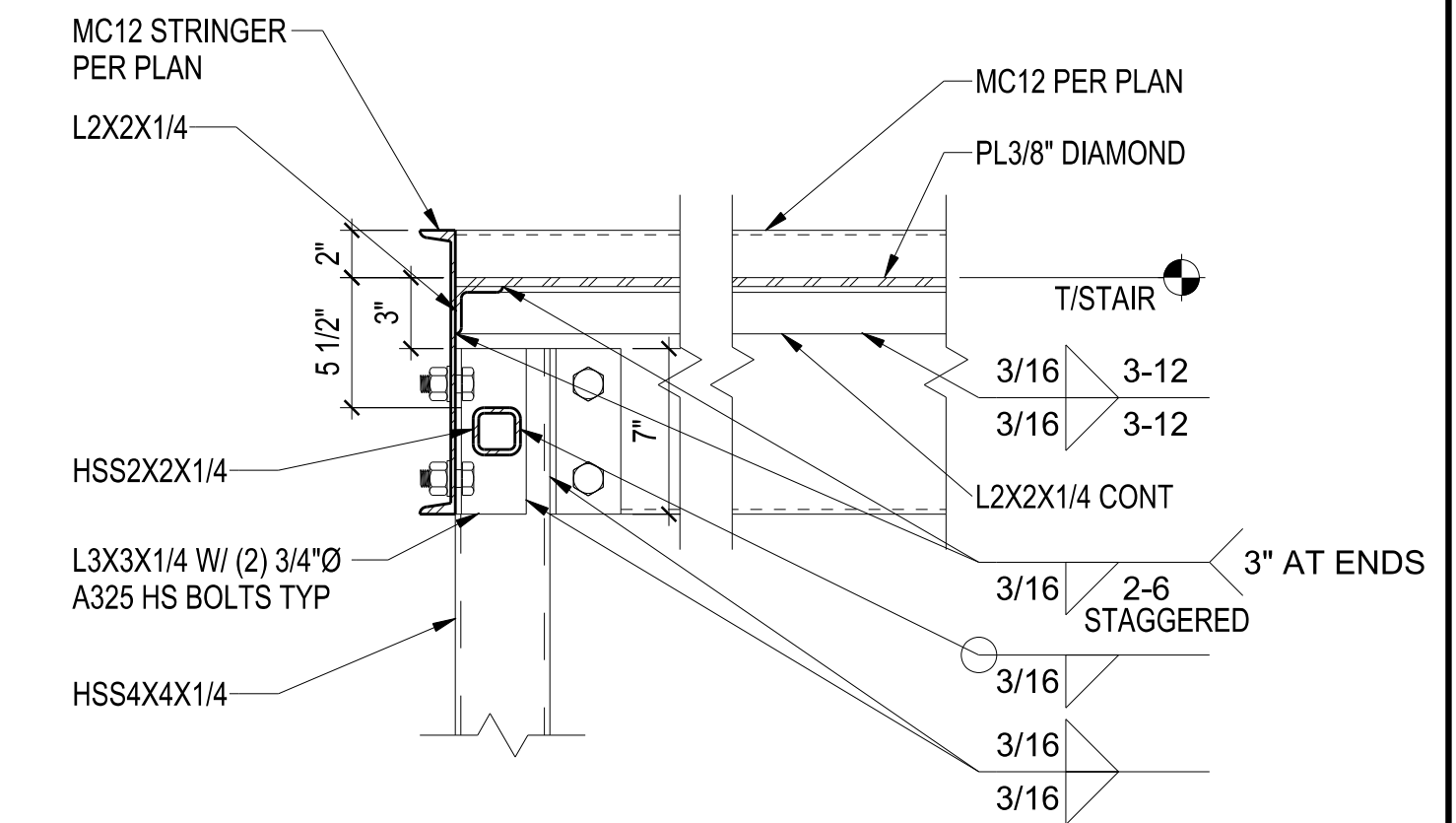

8 STAIR FRAMING DETAIL
1 1/2" = 1'-0"

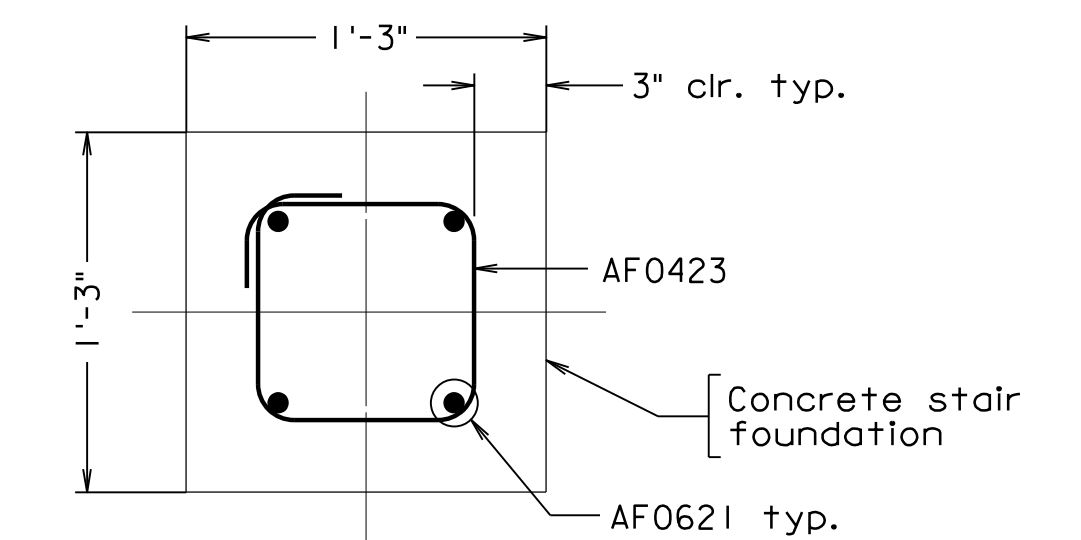

SECTION D-D - STAIR FOUNDATION SECTION
1 1/2" = 1'-0"

Note:
Washers are required for all nuts.

Scale: 1/4" = 1'-0" unless otherwise noted

© 2023, Commonwealth of Virginia

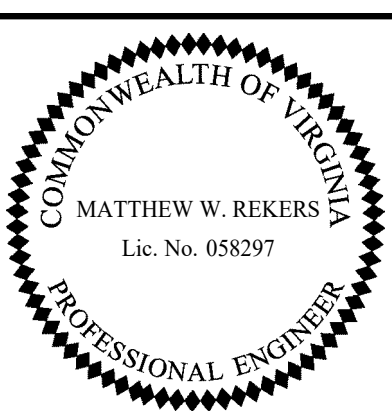

TRANSYSTEMS
RICHMOND, VA
STRUCTURAL ENGINEER

COMMONWEALTH OF VIRGINIA DEPARTMENT OF TRANSPORTATION STRUCTURE AND BRIDGE DIVISION					
METAL STAIR DETAILS (2 OF 3)					
No.	Description	Date	Designed: M.W.R.	Date	Plan No.
	Revisions		Drawn: H.R.N.	Apr. 2023	300-46
			Checked: M.W.R.		41 of 42

STATE	FEDERAL AID		STATE	SHEET
ROUTE	PROJECT		ROUTE	PROJECT
VA.			311	0311-080-913, B618
				42

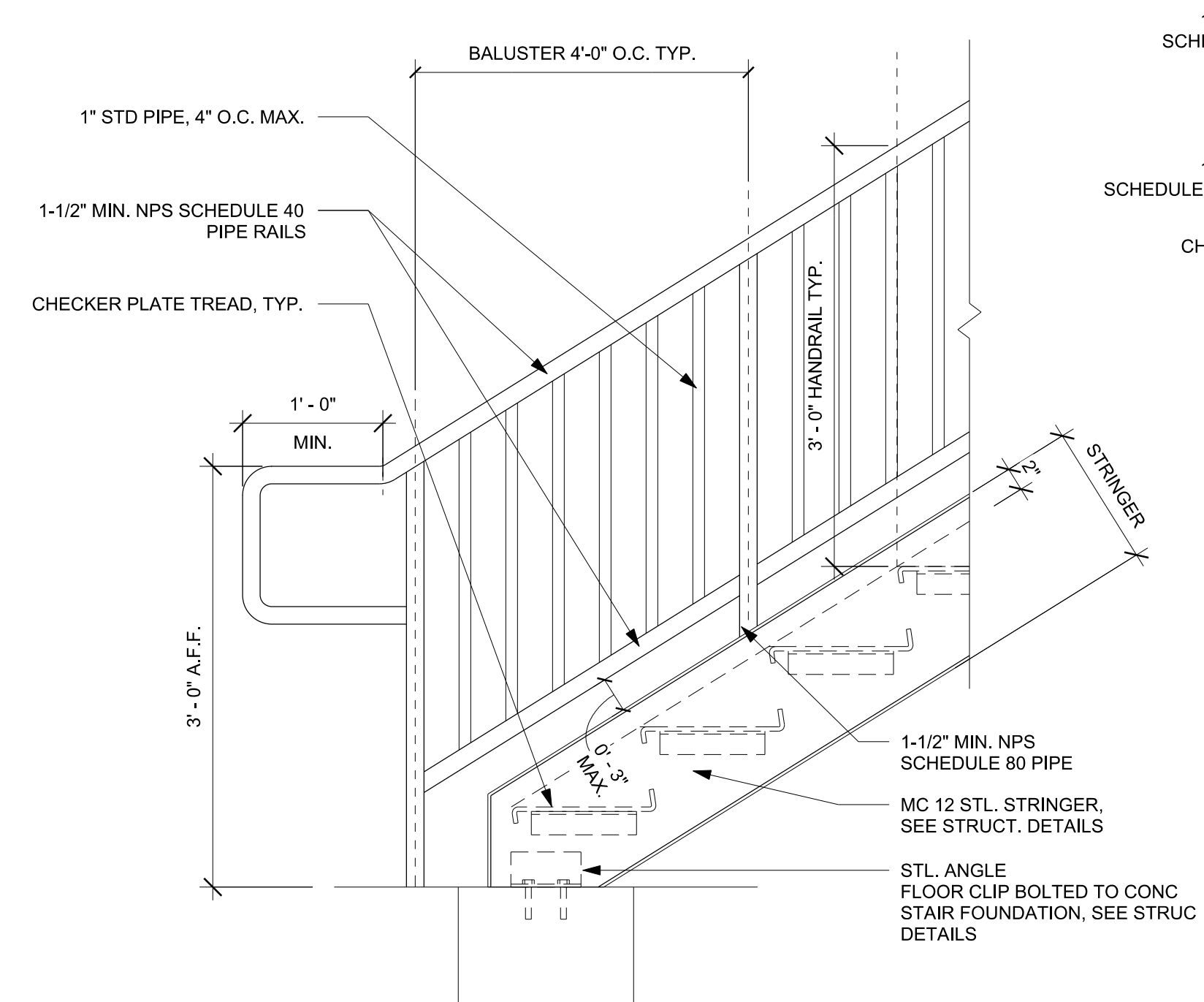

1 HANDRAIL BASE DETAIL
1" = 1'-0"

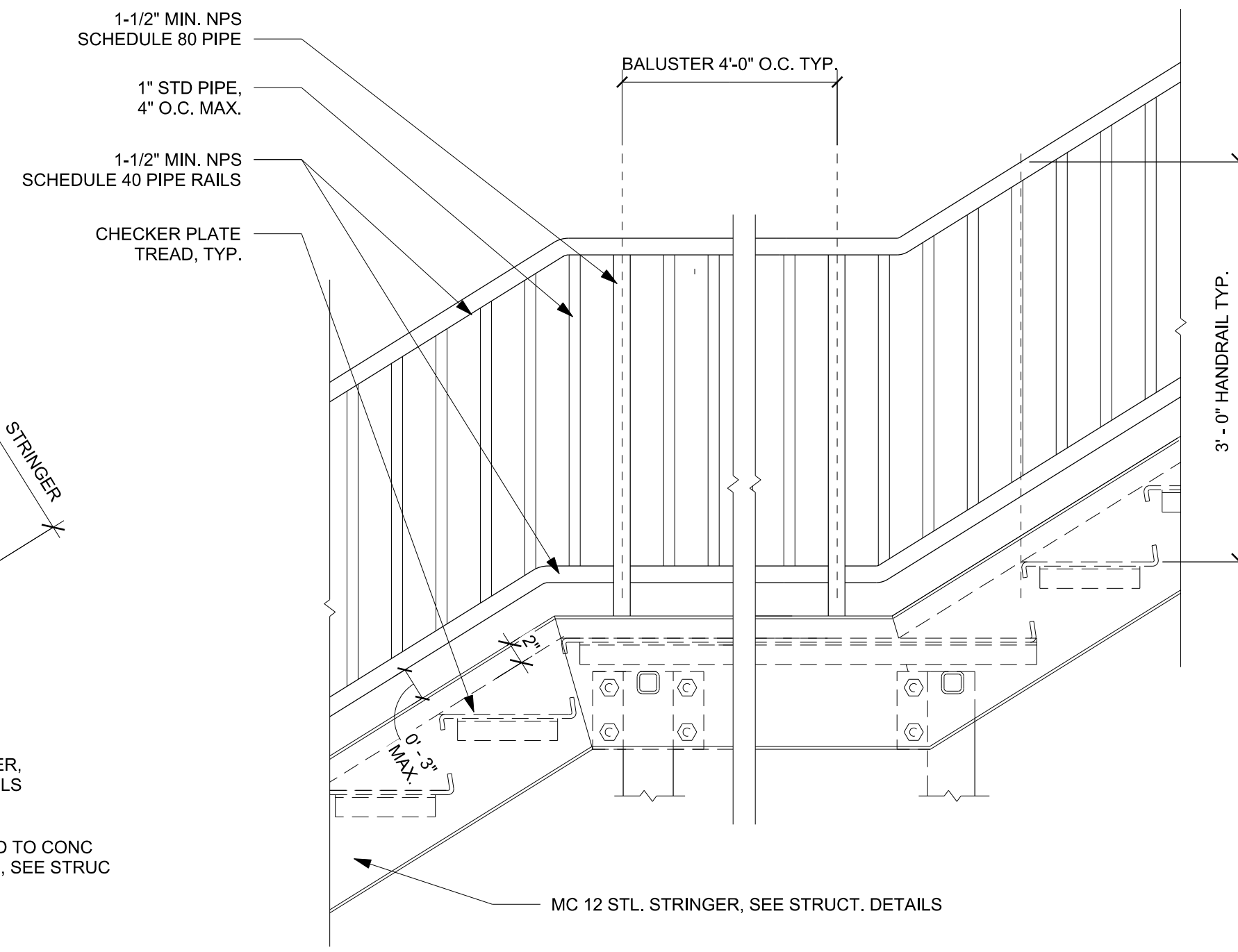

2 HANDRAIL MIDDLE LANDING DETAIL
1" = 1'-0"

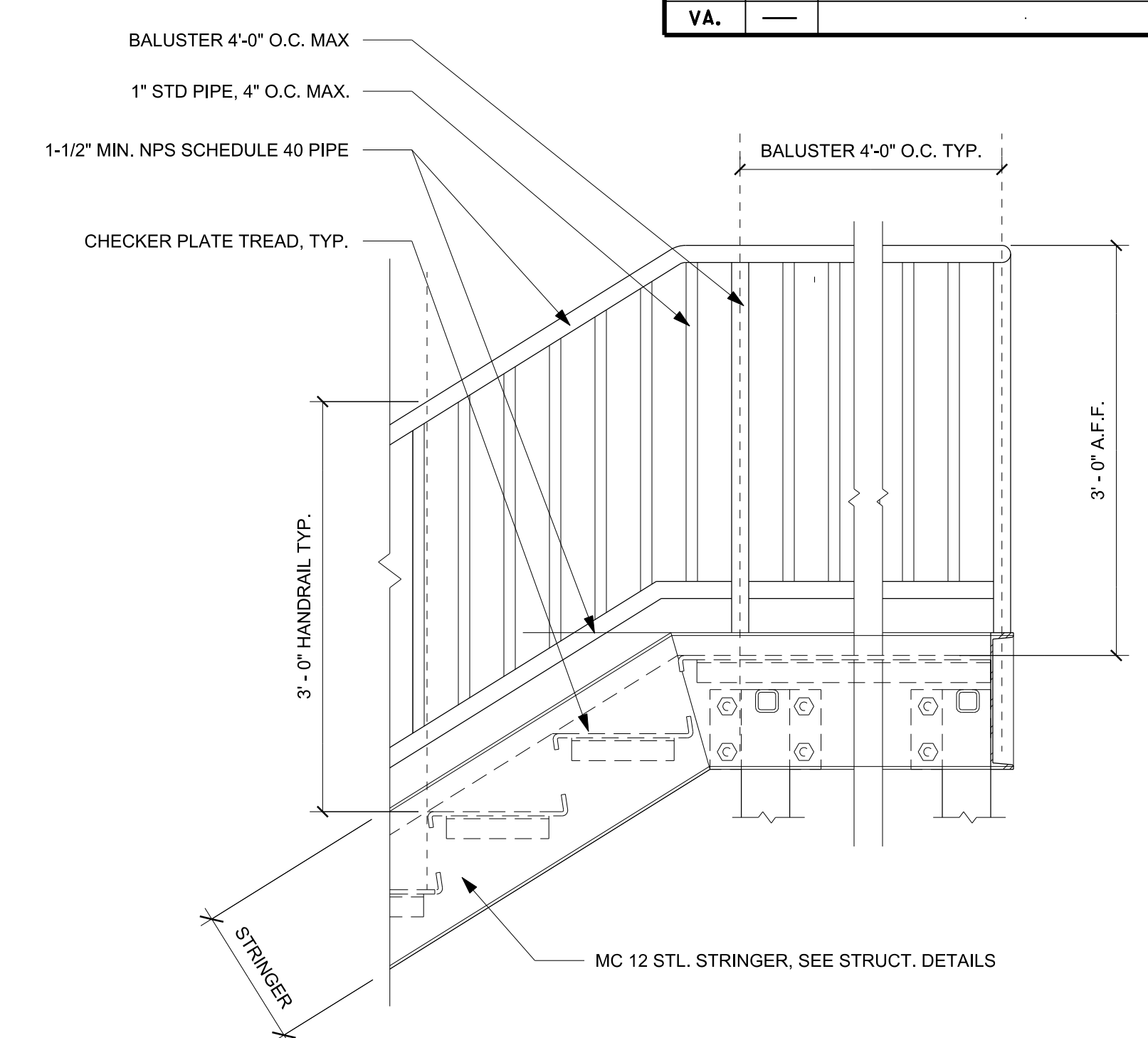

3 HANDRAIL TOP DETAIL
1" = 1'-0"

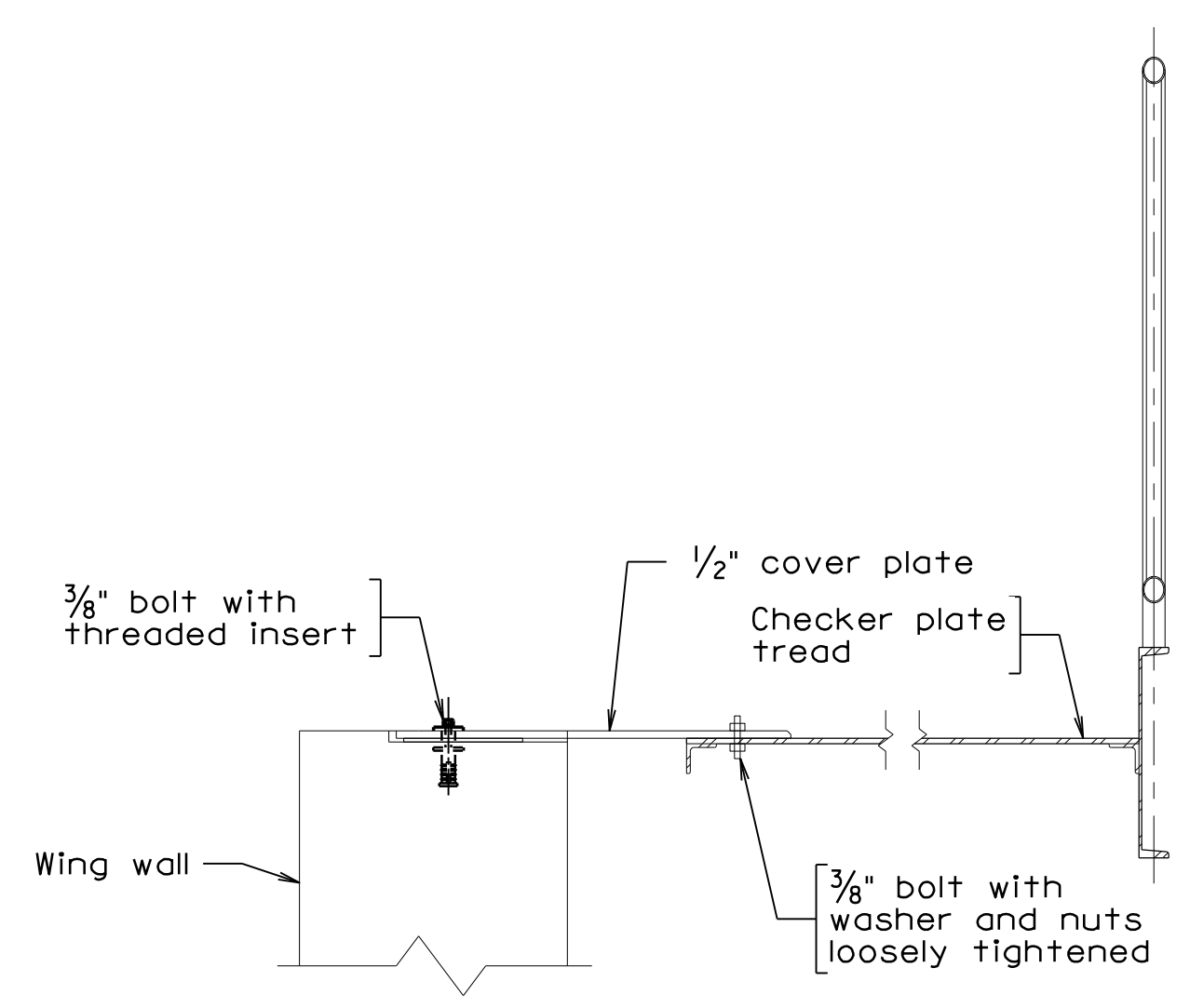

COVER PLATE DETAILS 1
1" = 1'-0"

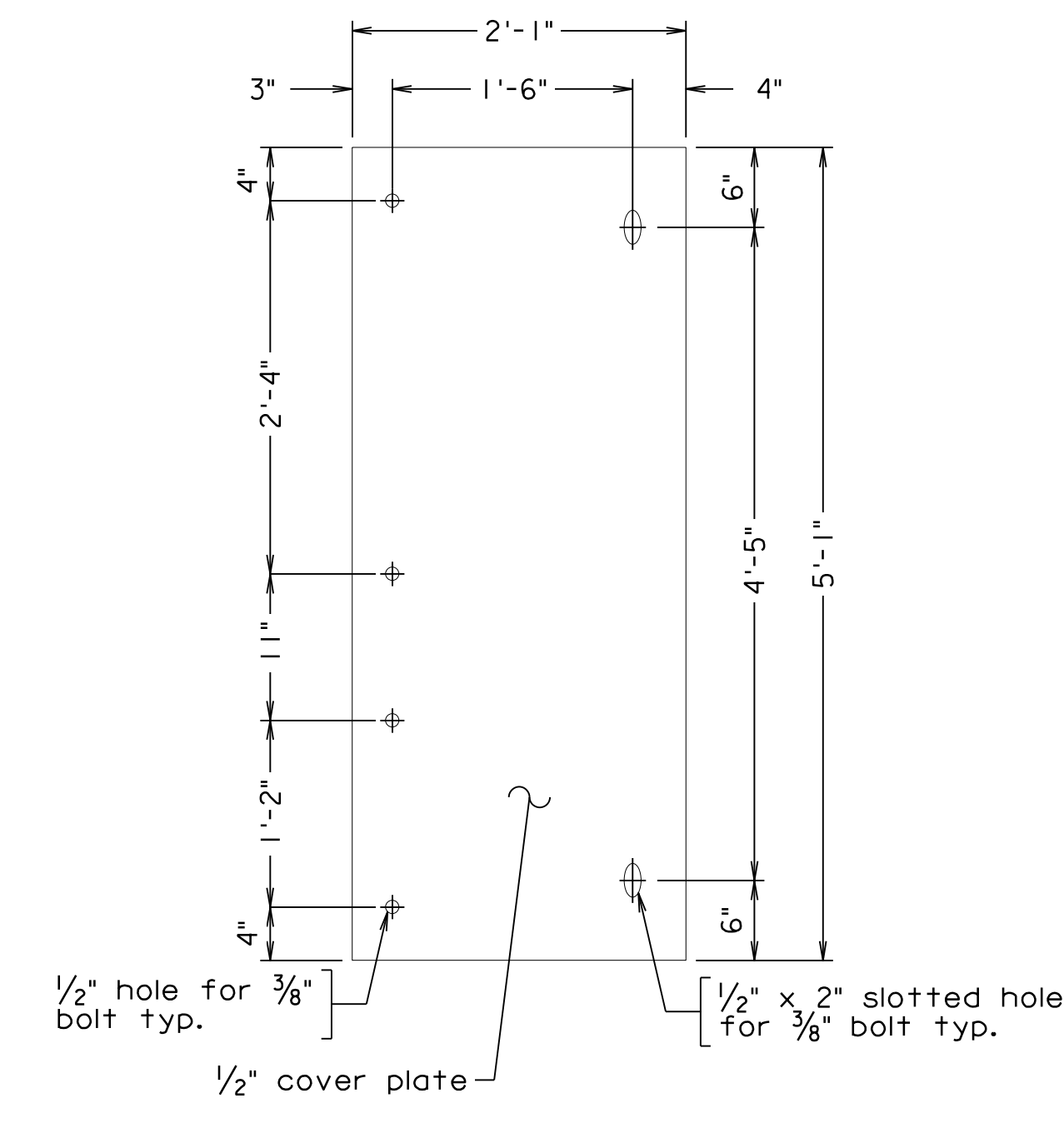

COVER PLATE DETAILS 2
1" = 1'-0"

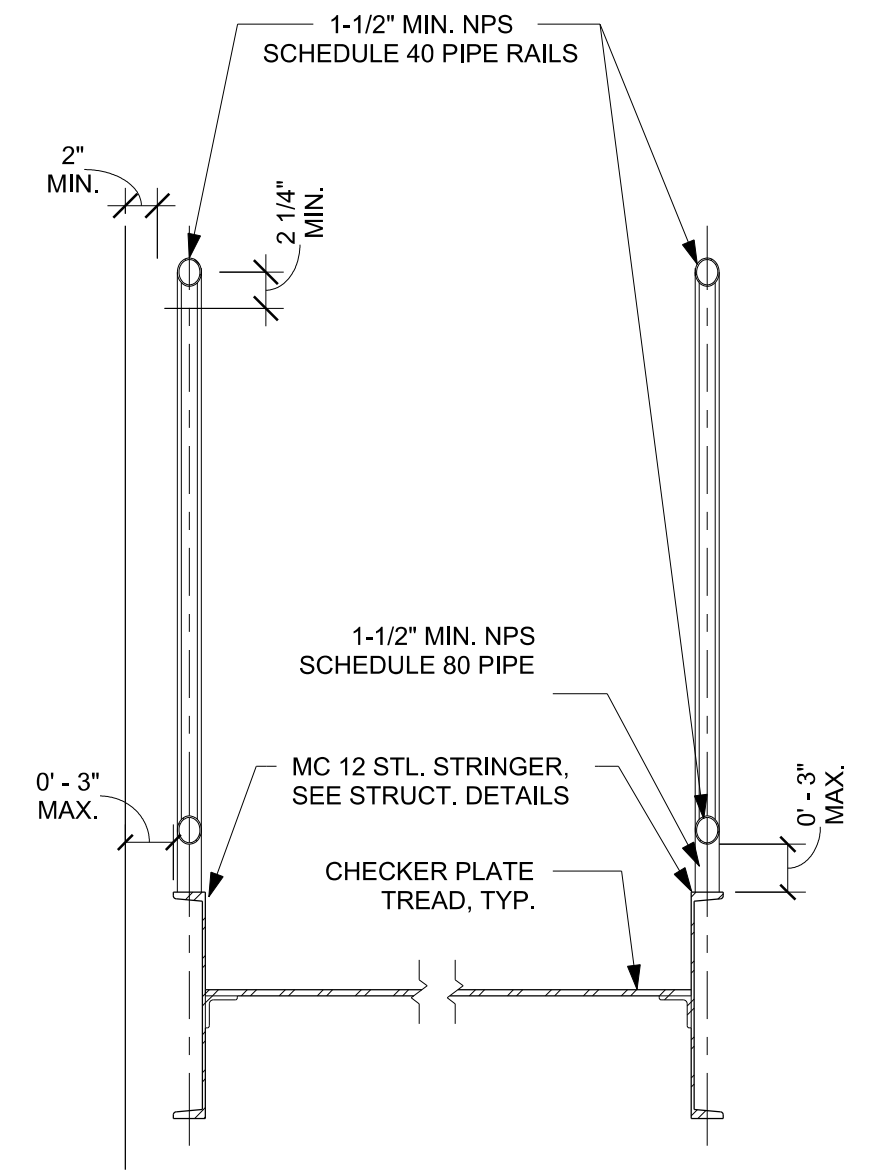

7 STAIR DETAIL AT TREAD
1" = 1'-0"

Note:
All handrails and fencing to be grounded in accordance with VDOT Road and Bridge Standards FE-6 (Page 503.07).
See VDOT Road and Bridge Standard HR-1 (Page 601.05) for HR-1 Type I and Type II Handrail details. Handrails shall be painted brown.

Scale: 1/4" = 1'-0" unless otherwise noted

© 2023, Commonwealth of Virginia

300-46-42.dgn

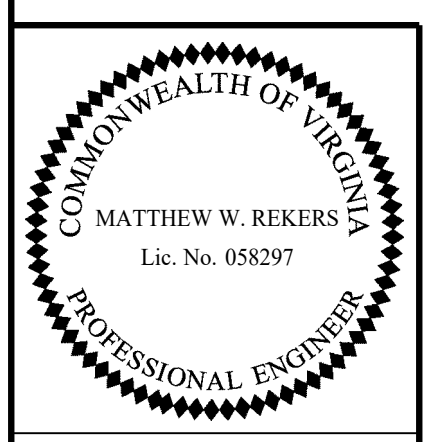

TRANSYSTEMS
RICHMOND, VA
STRUCTURAL ENGINEER

COMMONWEALTH OF VIRGINIA DEPARTMENT OF TRANSPORTATION STRUCTURE AND BRIDGE DIVISION				
METAL STAIR DETAILS (3 OF 3)				
No.	Description	Date	Designed: N.M.A. Drawn: N.M.A. Checked: G.B.E.	Date Apr. 2023
Revisions			Plan No. 300-46	Sheet No. 42 of 42

Exhibit B

Construction Plans

PROJECT MANAGER LEONARD, GISINER, 540-387-5457, VDOT, SALEM DISTRICT
 SURVEYED BY, DATE S.L. HOLLANDSWORTH, 11-15-18, 540-387-5227, VDOT, SALEM DISTRICT
 DESIGN BY TRANSYSTEMS, CORPORATION - (678) 244-9730
 SUBSURFACE UTILITY BY, DATE N/A

TRAFFIC MANAGEMENT PLAN

	REVISED	STATE	ROUTE	STATE PROJECT	SHEET NO.
		VA.	311	0311-080-913 R201, B618	1K(1)

DESIGN FEATURES RELATING TO CONSTRUCTION OR TO REGULATION AND CONTROL OF TRAFFIC MAY BE SUBJECT TO CHANGE AS DEEMED NECESSARY BY THE DEPARTMENT



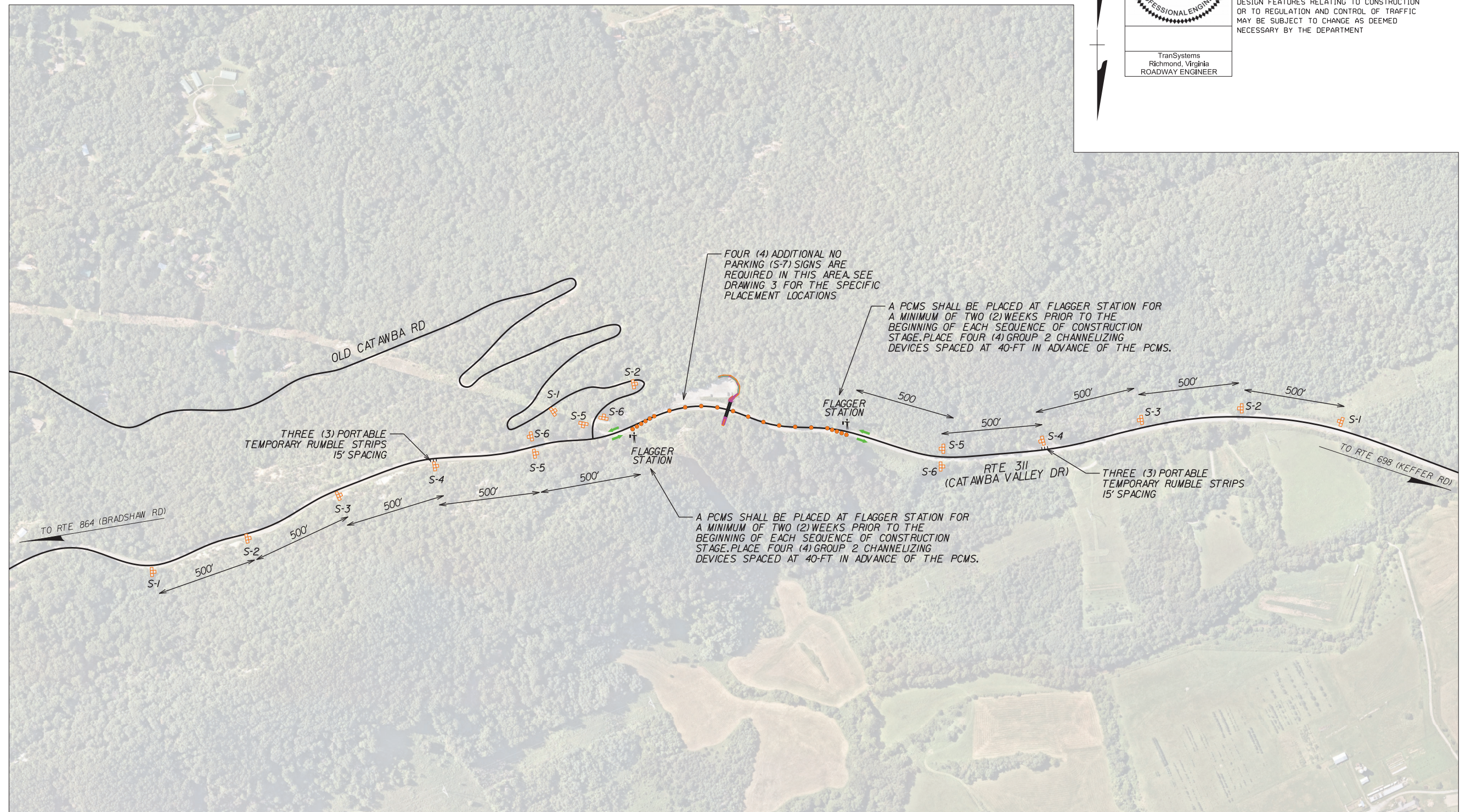



TranSystems
Richmond, Virginia
ROADWAY ENGINEER



NOTE: ALL SIGNS SHALL BE ORANGE IN COLOR.

LEGEND

-  PORTABLE TEMPORARY RUMBLE STRIPS
-  TRAFFIC FLOW ARROW
-  TEMPORARY TRAFFIC CONTROL SIGN
-  GROUP 2 CHANNELIZING DEVICE

						
S-1 W20-1 48" X 48"	S-2 W20-4 48" X 48"	S-3 W20-V26 48" X 48"	S-4 W3-4 48" X 48"	S-5 W20-7a 48" X 48"	S-6 G20-2(V) 60" X 24"	S-7 R8-3a 48" X 48"

SCALE: 0 250' 500'

PROJECT: 0311-080-913

SHEET NO.: 1K(1)

PROJECT MANAGER: LEONARD, GISINER, 540-387-5457, VDOT, SALEM DISTRICT
SURVEYED BY, DATE S.L. HOLLANDS WOBLE, 11-15-18, 540-387-5227, VDOT, SALEM DISTRICT
DESIGN BY TRANSSYSTEMS, CORPORATION - (678) 244-9730
SUBSURFACE UTILITY BY, DATE N/A

TRANSPORTATION MANAGEMENT PLAN

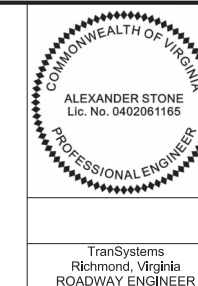

REVISED	STATE	ROUTE	STATE PROJECT	SHEET NO.
	VA.	311	0311-080-913 R201, B618	1K

DESIGN FEATURES RELATING TO CONSTRUCTION OR TO REGULATION AND CONTROL OF TRAFFIC MAY BE SUBJECT TO CHANGE AS DEEMED NECESSARY BY THE DEPARTMENT

TranSystems
Richmond, Virginia
ROADWAY ENGINEER

INTRODUCTION

PROJECT: PEDESTRIAN BRIDGE OVER ROUTE 311, TYPE B (CATEGORY III)
EXISTING CORRIDOR SPEED LIMIT IS 55 MPH, WINDING ROAD SIGNS AT PROJECT LOCATION HAVE A 35 MPH POSTED WORK ZONE(S) LENGTH; WORK ZONE LENGTH IS VARIABLE AS REFLECTED BELOW.

WORK ZONE(S) WIDTH; VARIABLE WIDTH (DUE TO EXISTING ROADWAY)

- ROUTE 311; STATION 43+40.10 TO STATION 44+67.05 (0.024 MILES / 127 FEET)

IMPACT ON TRAFFIC: ROUTE 311 ONE TRAVEL LANE SHALL REMAIN OPEN EXCEPT DURING THE INSTALLATION OF THE STEEL BEAMS FOR THE BRIDGE.

MATERIAL AND EQUIPMENT STORAGE: THE CONTRACTOR SHALL STORE ALL CONSTRUCTION EQUIPMENT AND MATERIALS IN THE DESIGNATED AREA OF THE PARKING LOT REFLECTED IN THE PLANS BEYOND THE CLEAR ZONE AND/OR DYNAMIC DEFLECTION AREA OF PHYSICAL BARRIERS AT ALL LOCATIONS.

ALLOWABLE WORK HOURS: 7AM-6PM MONDAY-FRIDAY UNLESS OTHERWISE APPROVED BY THE ENGINEER

TEMPORARY TRAFFIC CONTROL (TTC) PLAN

TEMPORARY TRAFFIC CONTROL REFERENCE: THE WORK ZONE SHALL BE MAINTAINED IN ACCORDANCE WITH AN APPROVED MAINTENANCE OF TRAFFIC (MOT)/TEMPORARY TRAFFIC CONTROL (TTC) PLAN, 2011 VIRGINIA WORK AREA PROTECTION MANUAL (VWAPM) REVISION 2/JANUARY, 2020, 2009 MANUAL ON UNIFORM TRAFFIC CONTROL DEVICES (MUTCD), INCLUDING ALL CURRENT REVISIONS OF THE MUTCD, VDOT 2020 ROAD AND BRIDGE SPECIFICATIONS, AND VDOT 2016 ROAD AND BRIDGE STANDARDS.

SPECIFIC APPLICABLE TYPICAL TEMPORARY TRAFFIC CONTROL FIGURES AND NOTES FROM CHAPTER 6H, TYPICAL APPLICATIONS, OF THE 2011 VWAPM INCLUDE:

FIG. TTC-23.2, LANE CLOSURE ON A TWO-LANE ROADWAY USING FLAGGERS
FIG. TTC-53.0, SIGNING FOR PROJECT LIMITS

THE CONTRACTOR MAY USE OTHER TYPICAL APPLICATIONS OR COMBINATIONS THEREOF AS DEEMED NECESSARY AND/OR APPROVED BY THE ENGINEER.

ENTRANCES AND INTERSECTIONS AFFECTED: ENTRANCES (MCAFFEE KNOB'S TRAIL), APPALACHIAN TRAIL, AND AEP FIRE ROAD

THE CONTRACTOR IS TO ENSURE ALL PRIVATE ENTRANCES SHALL REMAIN ACCESSIBLE DURING CONSTRUCTION.

TYPICAL SECTIONS: REFER TO THIS SHEET

GENERAL NOTES

1. UNLESS OTHERWISE APPROVED OR DIRECTED BY THE ENGINEER, THE CONTRACTOR SHALL PLAN AND PROSECUTE SEQUENCE OF CONSTRUCTION WORK ACTIVITIES IN ACCORDANCE WITH THE APPROVED TRANSPORTATION MANAGEMENT PLAN (TMP).

2. IT IS NOT THE INTENT OF THE TRANSPORTATION MANAGEMENT PLAN TO ENUMERATE EVERY DETAIL WHICH MUST BE CONSIDERED IN THE CONSTRUCTION OF EACH SEQUENCE OF CONSTRUCTION STAGE BUT ONLY TO SHOW THE GENERAL FEATURES NECESSARY IN PROVIDING FOR THE PROPER AND SAFE HANDLING OF TRAFFIC THROUGH THE WORK ZONE(S). CONSTRUCTION METHODS USED BY THE CONTRACTOR SHALL BE REVIEWED AND APPROVED BY THE ENGINEER.

3. THE CONTRACTOR MAY SUBMIT AN ALTERNATE TEMPORARY TRAFFIC CONTROL PLAN TO THE ENGINEER FOR APPROVAL AT LEAST THIRTY (30) DAYS PRIOR TO PERFORMING THE WORK, AS NO DEVIATIONS FROM THE APPROVED PLAN WILL BE ALLOWED WITHOUT PRIOR WRITTEN APPROVAL OF THE ENGINEER. THE CONTRACTOR SHALL ALLOW THE ENGINEER A MINIMUM OF TWO (2) WEEKS FOR REVIEW AND APPROVAL.

4. THE CONTRACTOR SHALL DESIGNATE A WORK SITE TRAFFIC CONTROL SUPERVISOR (WTS) WHO SHALL BE RESPONSIBLE FOR THE INSTALLATION AND MAINTENANCE OF TEMPORARY TRAFFIC CONTROL DEVICES AND BE AVAILABLE TWENTY-FOUR (24) HOURS PER DAY, SEVEN (7) DAYS A WEEK IN THE EVENT OF AN EMERGENCY. FURTHERMORE, THE CONTRACTOR SHALL HAVE AT LEAST ONE PERSON CERTIFIED IN INTERMEDIATE WORK ZONE TRAFFIC CONTROL TO SUPERVISE, INSTALL, REMOVE, AND/OR MAINTAIN TEMPORARY TRAFFIC CONTROL, AND ONE PERSON CERTIFIED IN BASIC WORK ZONE TRAFFIC CONTROL TO ADEQUATELY MAINTAIN THE WORK ZONE(S).

5. MEASURES SHALL BE TAKEN TO ENSURE THAT ADEQUATE SIGHT DISTANCE DURING CONSTRUCTION OPERATIONS IS MAINTAINED; TRAFFIC CONTROL DEVICES, CONSTRUCTION EQUIPMENT, STORED MATERIALS AND SUPPLIES OR ANY OTHER OBSTACLE SHALL NOT INTERFERE WITH SIGHT DISTANCES IN PROXIMITY OF INTERSECTIONS, INTERSECTING OR CROSSING ROUTES, AND ENTRANCES. EQUIPMENT AND / OR MATERIALS SHALL NOT BE STORED WITHIN THE ESTABLISHED CLEAR ZONE OF THE ROADWAYS LANES AND/OR DYNAMIC DEFLECTION AREA OF PHYSICAL BARRIERS.

6. SIGNS NO LONGER APPLICABLE AND/OR IN CONFLICT WITH OTHER TRAFFIC CONTROL DEVICES SHALL BE REMOVED AND/OR COVERED WHEN NO LONGER NECESSARY. ALL OTHER SIGNS SHALL BE PROPERLY ALIGNED/ORIENTED AND MAINTAINED.

7. PROPOSED TEMPORARY TRAFFIC CONTROL PLANS DEPICT TEMPORARY TRAFFIC CONTROL, THE DAILY CONTROL OF TRAFFIC, INCLUDING THE PLACEMENT, INSTALLATION, MAINTENANCE AND REMOVAL OF TEMPORARY TRAFFIC CONTROL DEVICES, SHALL BE THE CONTRACTOR'S SOLE RESPONSIBILITY. THE DAILY EFFORTS REQUIRED TO MANIPULATE TRAFFIC PATTERNS TO CONNECT NEW TO EXISTING ROADS BY CONSTRUCTING PAVEMENT OVERLAYS ARE THE RESPONSIBILITY OF THE CONTRACTOR. THE CONTRACTOR SHALL BE RESPONSIBLE FOR SAFE INGRESS / EGRESS FROM CONSTRUCTION ACCESS POINTS.

8. ALL TEMPORARY TRAFFIC CONTROL (SIGNS AND PAVEMENT MARKINGS) SHOWN IN THE PLANS ARE APPROXIMATE. ADJUSTMENTS MAY BE MADE BASED ON FIELD CONDITIONS WITH PRIOR APPROVAL AND/OR DISCRETION OF THE ENGINEER.

9. MINIMUM ALLOWABLE THROUGH LANE WIDTH THAT SHALL BE MAINTAINED IS ELEVEN (11) FEET ON ROUTE 311.

10. AT THE CONCLUSION OF EACH WORK SHIFT, ALL AREAS WITHIN THE CLEAR ZONE NOT ADEQUATELY PROTECTED SHALL BE BACKFILLED WITH AGGREGATE BASE MATERIAL OR OTHER APPROVED MATERIAL SOURCE TO FORM A 6" DESIRED (4" MINIMUM) SAFETY WEDGE AGAINST THE EXISTING PAVEMENT SURFACE. ALL ASSOCIATED COSTS FOR TRANSPORTING, FURNISHING, PLACING, MAINTAINING AND REMOVING THE SAFETY WEDGE SHALL BE INCLUDED IN COSTS FOR OTHER CONTRACTUAL PAY ITEMS AS NO ADDITIONAL COMPENSATION WILL BE ALLOWED.

11. LANE CLOSURE REQUESTS SHALL BE SUBMITTED TO THE VDOT TRAFFIC OPERATIONS CENTER (TOC) AND VDOT PROJECT MANAGER FOR COORDINATION PURPOSES, AT LEAST SEVEN (7) DAYS IN ADVANCE OF THE PROPOSED LANE CLOSURE AND NO LATER THAN CLOSE OF BUSINESS WEDNESDAY THE WEEK PRIOR TO CLOSURE. THE CONTRACTOR SHALL CONFIRM AT LEAST TWENTY-FOUR (24) HOURS PRIOR TO ANY SCHEDULED LANE CLOSURE IN ORDER FOR THE TOC TO POST LANE CLOSURE INFORMATION ON THE VDOT WEBSITE AND VA 511 SYSTEM. THIS PROJECT CONTAINS WORK WHICH WILL REQUIRE LANE CLOSURES ON RTE 311. THE CONTRACTOR SHALL COORDINATE ALL LANE CLOSURES IN ACCORDANCE WITH LCAMS SPECIFICATIONS AND SPECIAL PROVISIONS. LANE CLOSURES SHALL OCCUR OUTSIDE OF PEAK COMMUTER TRAVEL HOURS.

12. THE CONTRACTOR SHALL PROVIDE POSITIVE DRAINAGE. TEMPORARY DRAINAGE SHALL BE PROVIDED AS REQUIRED AND/OR AS SHOWN ON THE PLANS TO PREVENT PONDING OF WATER ON THE ROADWAY AND RUNOFF OF WATER OFF SITE AND ONTO ADJACENT PROPERTIES.

13. PORTABLE CHANGEABLE MESSAGE SIGNS (PCMS) SHALL BE INSTALLED A MINIMUM OF TWO (2) WEEKS PRIOR TO BEGINNING OF EACH SEQUENCE OF CONSTRUCTION STAGE TO ALERT MOTORISTS OF AN UPCOMING WORK ZONE, A NEW CONSTRUCTION STAGE OR TRAFFIC PATTERN, AND/OR ROAD CLOSURE.

14. THE CONTRACTOR SHALL PERFORM TEST PIT EXCAVATIONS IN ADVANCE TO VERIFY THE EXACT LOCATIONS AND ELEVATIONS OF THE EXISTING UTILITIES IN ORDER TO DETERMINE IF ANY OF THESE UTILITIES WILL BE IN CONFLICT WITH THE PROPOSED WORK. ALL TEST PIT EXCAVATIONS SHALL BE IN ACCORDANCE WITH THE APPLICABLE MISS UTILITY LAW OR AS DIRECTED BY THE ENGINEER.

15. NATIONAL PARK SERVICE IS TO BE NOTIFIED 30 DAYS BEFORE THE PARKING LOT IS CLOSED TO THE PUBLIC:
CONTACT: KEITH STEGALL
CHIEF OF FACILITIES MAINTENANCE
APPALACHIAN NATIONAL SCENIC TRAIL
CELL: 301-712-6729
EMAIL: kstegall@nps.gov

16. ROANOKE COUNTY IS TO BE NOTIFIED WHEN AND BEFORE PARKING LOT IS TO BE CLOSED TO THE PUBLIC. ALSO WHEN NIGHT WORK IS TO BE DONE.
CONTACT: AMY T. WHITTAKER
PUBLIC INFORMATION OFFICER
OFFICE: 540-772-2010
CELL: 540-589-3089

17. THE CONTRACTOR SHALL INSTALL HIGH VISIBILITY TEMPORARY CONSTRUCTION FENCING AND ADDITIONAL "NO PARKING" SIGNS IN THE LOCATION SHOWN ON SHEET NO. 3 IN THE PLANS.

18. PRIOR TO COMMENCING WORK, THE CONTRACTOR SHALL CONTACT ROANOKE COUNTY EMS, ROANOKE COUNTY POLICE, AND CATAWBA FIRE DEPARTMENT TO PROVIDE ACCESS TO THE LOCKED GATED AREA FOR EMERGENCY ACCESS.

19. ALL TRAIL ENTRANCES AND PRIVATE ENTRANCES SHALL REMAIN ACCESSIBLE DURING CONSTRUCTION.

PUBLIC COMMUNICATION STRATEGIES

PROJECT DESCRIPTION:
• THE PROJECT WILL INCLUDE THE CONSTRUCTION OF A PEDESTRIAN BRIDGE OVER ROUTE 311 AND A RAMP AND STAIRWAY FROM THE PARKING LOT TO THE BRIDGE.

TRAFFIC IMPACTS:
• THERE WILL BE ONE SHORT CLOSURE OF ROUTE 311 IN ORDER TO INSTALL THE STEEL BEAMS ACROSS THE ROAD.
• THERE WILL BE LANE SHIFTS, BUT ONE LANE IN EACH DIRECTION WILL BE MAINTAINED.

GOALS:
• TO INFORM THE PUBLIC ABOUT THE PROJECT
• TO MINIMIZE DISRUPTION THROUGH PROACTIVE INFORMATION DISSEMINATION EFFORTS
• TO GATHER PUBLIC SUPPORT FOR THE PROJECT
• TO ESTABLISH A CRISIS COMMUNICATION PLAN

MESSAGES:
• BENEFITS AND PURPOSE OF THE PROJECT
• TRAFFIC IMPACTS AND INFORMATION ON ALTERNATE ROUTES
• CONTACTS FOR MORE INFORMATION

CRISIS COMMUNICATIONS PLAN:
• AS WITH ANY CRISIS, EMERGENCY RESPONDERS (911) SHOULD BE NOTIFIED IMMEDIATELY IF NECESSARY.
• THE AREA CONSTRUCTION ENGINEER (ACE) OR HIS DESIGNEE SHOULD BE NOTIFIED IMMEDIATELY.
• IF THE EMERGENCY IS TRAFFIC RELATED, THE ACE OR HIS DESIGNEE SHOULD IMMEDIATELY NOTIFY THE TRAFFIC OPERATIONS CENTER AT 540-375-0170.
• THE TRAFFIC OPERATIONS CENTER SHOULD IMMEDIATELY NOTIFY THE DISTRICT COMMUNICATIONS OFFICE: 540-387-5493.
• THE ACE, DISTRICT COMMUNICATION, AND TRAFFIC OPERATIONS CENTER (TOC) WILL WORK TOGETHER TO INFORM THE TRAVELING PUBLIC, EMERGENCY RESPONDERS, AND THE MEDIA ABOUT DELAYS AND UNEXPECTED CHANGES IN TRAFFIC PATTERNS USING THE CONTACT LIST AND OTHER RESOURCES IF NECESSARY.

SEQUENCE OF CONSTRUCTION

PHASE 0

1. SETUP LAYDOWN AREA IN PARKING LOT.
2. CLEAR AND GRUB AREAS NECESSARY TO INSTALL PERIMETER CONTROLS AND CONSTRUCTION ENTRANCES.
3. INSTALL PERIMETER SILT FENCE AND STABILIZED CONSTRUCTION ENTRANCES.

PHASE 1

1. CONSTRUCT THE BRIDGE ABUTMENTS ONE SIDE AT A TIME, UTILIZE TTC-23.2 (LANE CLOSURE ON A TWO-LANE ROADWAY USING FLAGGERS) FOR ANY WORK THAT MAY IMPEDE TRAFFIC FLOW ON ROUTE 311.

PHASE 2

1. CONSTRUCT THE BRIDGE ACROSS ROUTE 311, UTILIZE TTC-23.2 (LANE CLOSURE ON A TWO-LANE ROADWAY USING FLAGGERS) TO CLOSE THE ROAD FOR A SHORT DURATION TO INSTALL STEEL BEAMS ACROSS ROUTE 311.

PHASE 3

1. CONSTRUCT THE TRAIL FROM THE PARKING LOT TO THE BRIDGE.

EMERGENCY RESPONSE CONTACTS

Contacts	Phone Number
Roanoke County Police	911 (EMERGENCY)
Roanoke County EMS	(540) 777-8701
Catawba Fire Department	(540) 777-8701
Area Construction Engineer Tony Handy, PE, LS, CCM	(540) 375-3595
District Communications Manager Jason Bond	(540) 387-5493
VDOT Traffic Operations Center	(540) 375-0170

PROJECT 0311-080-913	SHEET NO. 1K
-------------------------	-----------------

PROJECT MANAGER LEONARD, GISINER, 540-387-5457, VDOT, SALEM DISTRICT
 SURVEYED BY, DATE S.J. HOLLANDSWORTH, 11-15-18, 540-387-5227, VDOT, SALEM DISTRICT
 DESIGN BY TRANSYSTEMS, CORPORATION, (678) 244-9730
 SUBSURFACE UTILITY BY, DATE N/A

GRADING PLAN

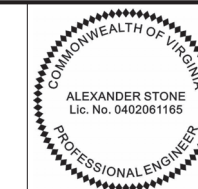

REVISED	STATE	ROUTE	STATE PROJECT	SHEET NO.
	VA.	311	0311-080-913 R201, B618	3A

DESIGN FEATURES RELATING TO CONSTRUCTION OR TO REGULATION AND CONTROL OF TRAFFIC MAY BE SUBJECT TO CHANGE AS DEEMED NECESSARY BY THE DEPARTMENT

TranSystems
Richmond, Virginia
ROADWAY ENGINEER

ELEVATION POINT

TYPE	STATION	ELEV	OFFSET
A1	BOR	23-49.84	1966.66' 03.00' RT
A3	EOL	23-50.29	1966.66' 03.00' RT
A4	EOL	23-53.29	1966.66' 03.00' RT
A5	BOR	23-53.29	1966.54' 03.00' LT
A6	EOL	23-48.20	1966.74' 03.00' RT
A7	EOL	23-59.13	1966.76' 03.00' RT
A8	EOL	23-59.13	1966.90' 03.00' LT
A9	TOR	23-37.84	1967.44' 03.00' LT
A10	BOR	23-32.84	1967.44' 03.00' LT
A11	TOR	23-37.87	1967.56' 03.00' RT
A12	EOL	23-32.84	1967.56' 03.00' RT
A14	BOR	23-31.91	1967.56' 03.00' RT
A15	TOR	23-01.91	1969.94' 03.00' LT
A16	BOR	22-96.02	1969.94' 03.00' LT
A17	TOR	23-01.91	1970.06' 03.00' RT
A18	EOL	22-96.91	1970.06' 03.00' RT
A20	BOR	22-95.08	1970.06' 03.00' RT
A21	TOR	22-65.08	1972.56' 03.00' RT
A23	EOL	22-64.31	1972.56' 03.00' RT
A24	EOL	22-57.67	1972.56' 03.00' RT
A26	BOR	22-56.95	1972.56' 03.00' RT
A27	TOR	22-64.69	1972.44' 03.00' LT
A28	BOR	22-57.31	1972.44' 03.00' LT
A29	TOR	22-26.95	1975.06' 03.00' RT
A31	EOL	22-25.50	1975.06' 03.00' RT
A32	EOL	22-20.50	1975.06' 03.00' RT
A34	BOR	22-20.17	1975.06' 03.00' RT
A35	TOR	22-26.23	1974.94' 03.00' LT
A36	BOR	22-20.34	1974.94' 03.00' LT
A37	TOR	21-88.98	1977.44' 03.00' LT
A38	BOR	21-82.79	1977.44' 03.00' LT
A39	TOR	21-90.17	1977.56' 03.00' RT
A41	EOL	21-87.79	1977.56' 03.00' RT
A42	BOR	21-82.79	1977.56' 03.00' RT
A46	TOR	21-52.79	1980.00' 03.00' LT
A49	EOL	21-42.16	1980.27' 04.00' LT
A51	EOL	21-37.16	1980.27' 04.00' LT
A52	TOR	21-52.79	1980.00' 03.00' RT
A53	EOL	21-42.16	1980.25' 05.00' RT
A54	EOL	21-37.16	1980.25' 05.00' RT
A55	EOL	20-47.16	1980.25' 05.08' LT
A56	EOL	20-47.16	1980.25' 05.08' RT
A57	EOL	20-09.16	1967.85' 05.08' RT
A58	EOL	20-09.16	1967.85' 05.08' LT
A59	EOL	20-42.16	1980.00' 05.08' LT
A60	EOL	20-42.16	1980.00' 05.08' RT
B1	EOT	23-53.33	1969.35' 06.42' RT
B2	EOT	23-53.29	1970.49' 07.83' RT
B3	EOT	23-50.09	1970.40' 06.00' RT
B4	EOT	23-37.87	1970.52' 06.00' RT
B5	EOT	23-32.84	1970.91' 06.00' RT
B6	EOT	23-01.91	1972.69' 06.00' RT
B7	EOT	22-96.91	1973.55' 06.00' RT
B8	EOT	22-64.69	1976.86' 06.00' RT
B9	EOT	22-57.31	1977.35' 06.00' RT
B10	EOT	22-26.23	1979.65' 06.00' RT
B11	EOT	22-20.34	1979.29' 06.00' RT
B12	EOT	21-90.17	1977.44' 06.00' RT
B13	INV	23-53.33	1969.90' 06.42' RT
B14	INV	23-56.36	1966.03' 19.80' RT
B15	DTC	23-56.36	1965.00' 37.94' RT

BOR - DENOTES BOTTOM OF RAMP
 TOR - DENOTES TOP OF RAMP
 EOL - DENOTES EDGE OF LANDING
 EOT - DENOTES EDGE OF TRENCH
 INV - DENOTES PIPE INVERT
 DTC - DENOTES V-DITCH INVERT

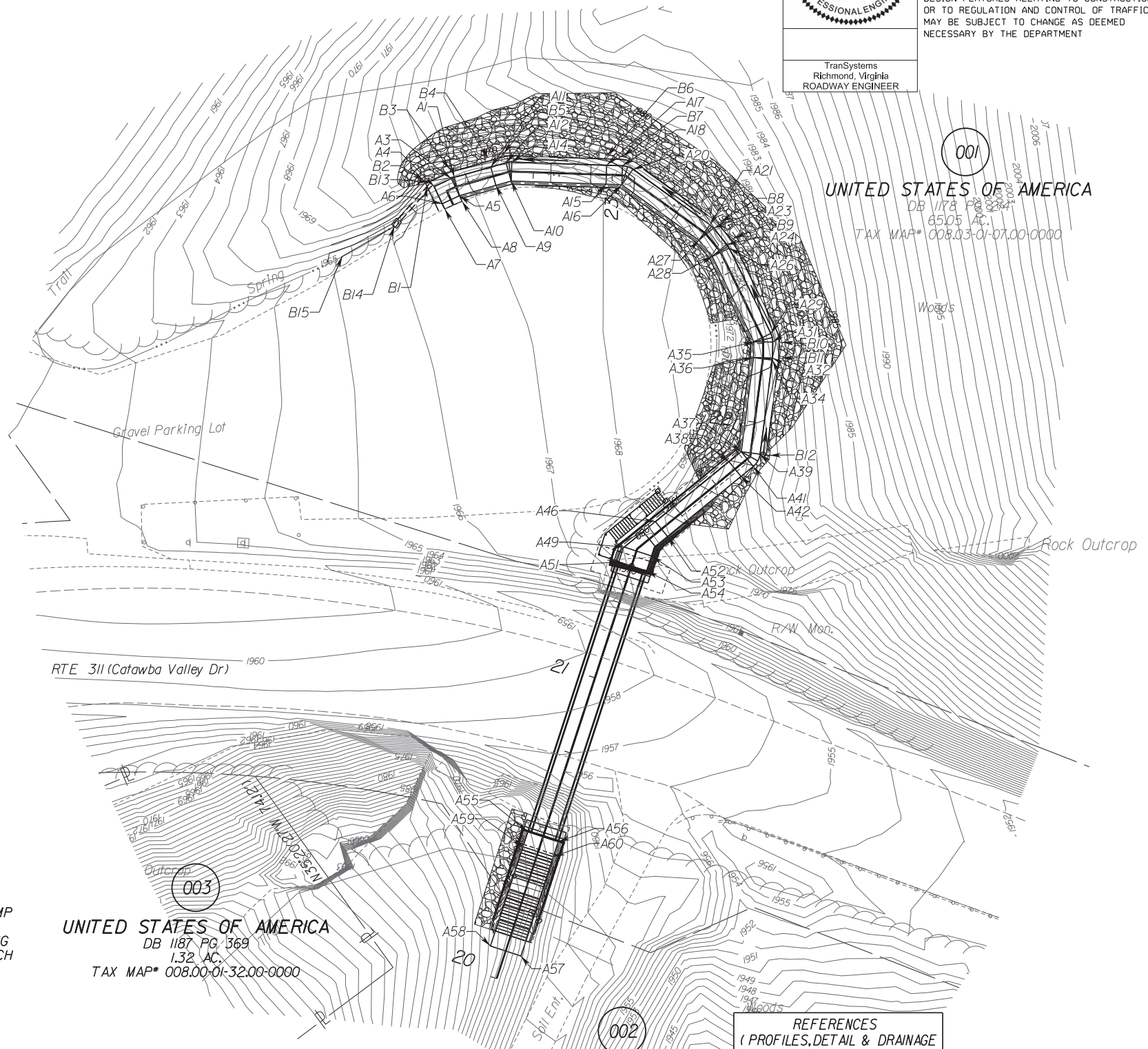

UNITED STATES OF AMERICA
 DB 1187 PG 369
 1.32 AC.
 TAX MAP* 008.00-01-32.00-0000

UNITED STATES OF AMERICA
 DB 1278 PG 440
 18.69 AC.
 TAX MAP* 008.00-01-35.02-0000

REFERENCES (PROFILES, DETAIL & DRAINAGE DESCRIPTION SHEETS, ETC.)

Typicals	2A-2A(2)
Roadway	3
Profile	3B
ESC Plan	5

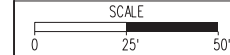

PROJECT	0311-080-913	SHEET NO.	3A
---------	--------------	-----------	----

PROJECT MANAGER LEONARD, GISINER, 540-387-5457, VDOT, SALEM DISTRICT
 SURVEYED BY, DATE S.J. HOLLANDSWORTH, 11-15-18, 540-387-5227, VDOT, SALEM DISTRICT
 DESIGN BY TRANSYSTEMS, CORPORATION, (678) 244-9730
 SUBSURFACE UTILITY BY, DATE N/A

ENVIRONMENTAL AVOIDANCE AREA OUTSIDE OF THE PROJECT LIMITS

REVISED	STATE	ROUTE	STATE PROJECT	SHEET NO.
	VA.	311	0311-080-913 R201, B618	3E(1)

DESIGN FEATURES RELATING TO CONSTRUCTION OR TO REGULATION AND CONTROL OF TRAFFIC MAY BE SUBJECT TO CHANGE AS DEEMED NECESSARY BY THE DEPARTMENT

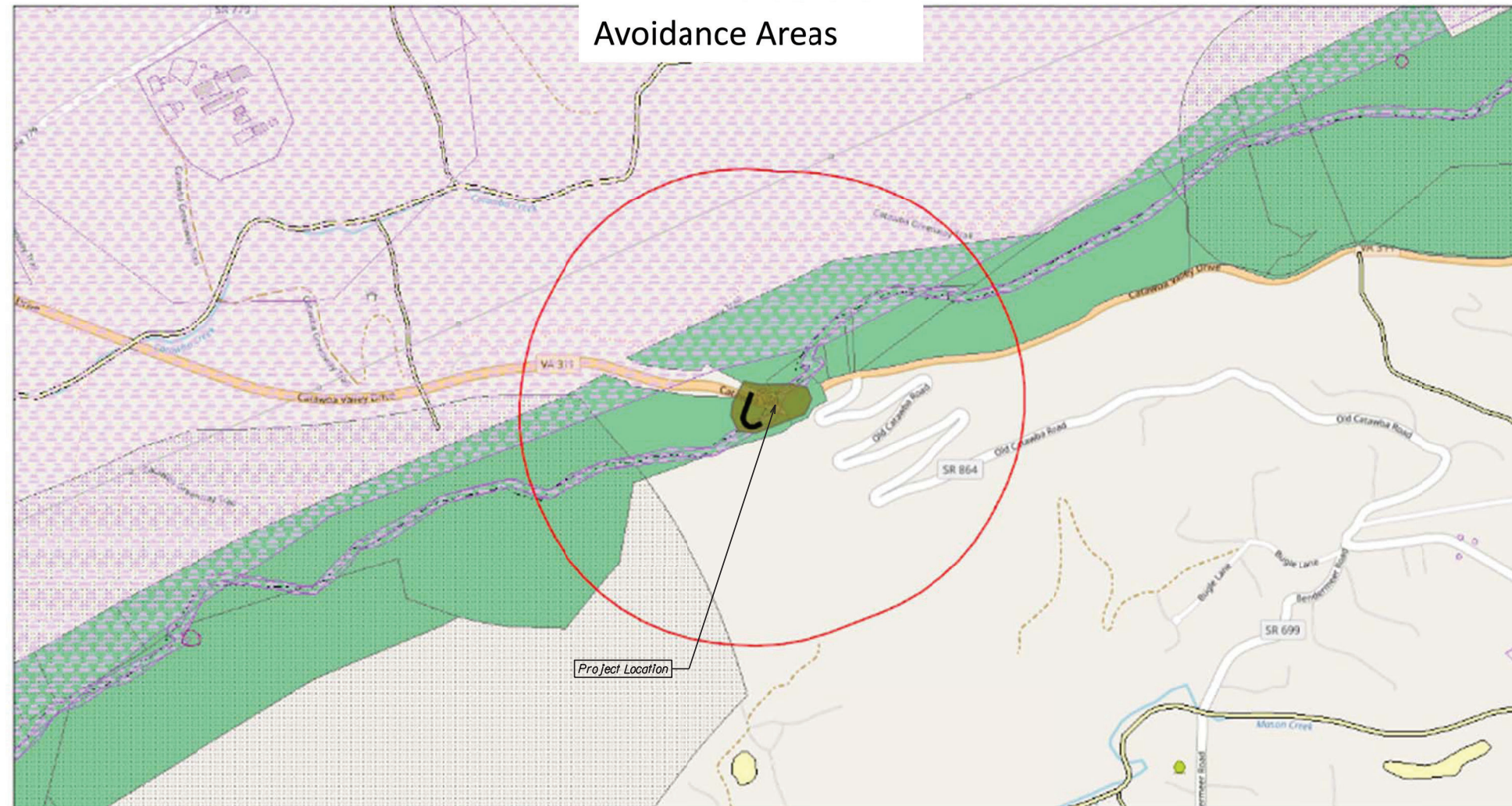

- | | | | | |
|------------------------|--------------------|---------|-----------------------------|--------------------------|
| Natural Heritage Sites | Architecture | Local | VOF Conservation Projects | EPA Brownfields |
| Federal Listed | Archaeology | Private | VDMME Sinkholes | EPA RCRA Sites |
| State Listed | NWI | State | Appalachian Trail | Large Quantity Generator |
| No Listing | Conservation Lands | VOF | DEQ Petroleum Release Sites | Small Quantity Generator |
| Critical Habitat | Federal | | | TSD |

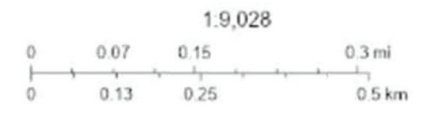

© OpenStreetMap (and) contributors, CC-BY-SA, VDOT, VDOT, LTD, CO, Richmond, VA, GIS SIG, Annex, 8th floor

- Abbreviations:
- ACM - Asbestos Containing Materials
 - BMP - Best Management Practice
 - CR - Cultural Resources
 - DEM - District Environmental Manager
 - ECI - Environmental Commitment Inspector
 - VDGIF - Department of Game and Inland Fisheries
 - FHWA - Federal Highway Administration
 - MOA - Memorandum of Agreement
 - MOU - Memorandum of Understanding
 - NEPA - National Environmental Policy Act
 - NOI - Notice of Intent
 - NWP - Nationwide Permit
 - TOYR - Time of Year Restriction
 - T&E - Threatened and Endangered Species
 - PCN - Pre-Construction Notification
 - VDEQ - Virginia Department of Environmental Quality
 - VMRC - Virginia Marine Resources Commission
 - USACE/COE - U.S. Army Corps of Engineers
 - USFWS - U.S. Fish and Wildlife Service
 - WOTUS - Waters of the United States
 - WQ - Water Quality

Notes:
 Information on this sheet is a reference document related to the Environmental Commitments, Conditions and Clearances applicable to this project. Refer to the controlling documents (Bid/Proposal/Contract Special Provisions, Final Construction Plans, etc.)
 Environmental shall be contacted regarding any field adjustments, construction Plan revisions, etc. prior to work proceeding to allow review to verify environmental compliance.

PROJECT	SHEET NO.
0311-080-913	3E(1)

PROJECT MANAGER LEONARD, GISINER, 540-387-5457, VDOT, SALEM DISTRICT
 SURVEYED BY, DATE S.L. HOLLANDSWORTH, 11-15-18, 540-387-5227, VDOT, SALEM DISTRICT
 DESIGN BY TRANSYSTEMS CORPORATION, (678) 244-9730
 SUBSURFACE UTILITY BY, DATE N/A

ENVIRONMENTAL COMMITMENTS PLAN SHEET

REVISED	STATE	ROUTE	STATE PROJECT	SHEET NO.
		311	0311-080-913 R201, B618	3E(2)

DESIGN FEATURES RELATING TO CONSTRUCTION OR TO REGULATION AND CONTROL OF TRAFFIC MAY BE SUBJECT TO CHANGE AS DEEMED NECESSARY BY THE DEPARTMENT

NOTE: CONTROLLING AGENCY FOR ALL UNITED STATES OF AMERICA PARCELS SHALL BE THE NATIONAL PARK SERVICE.

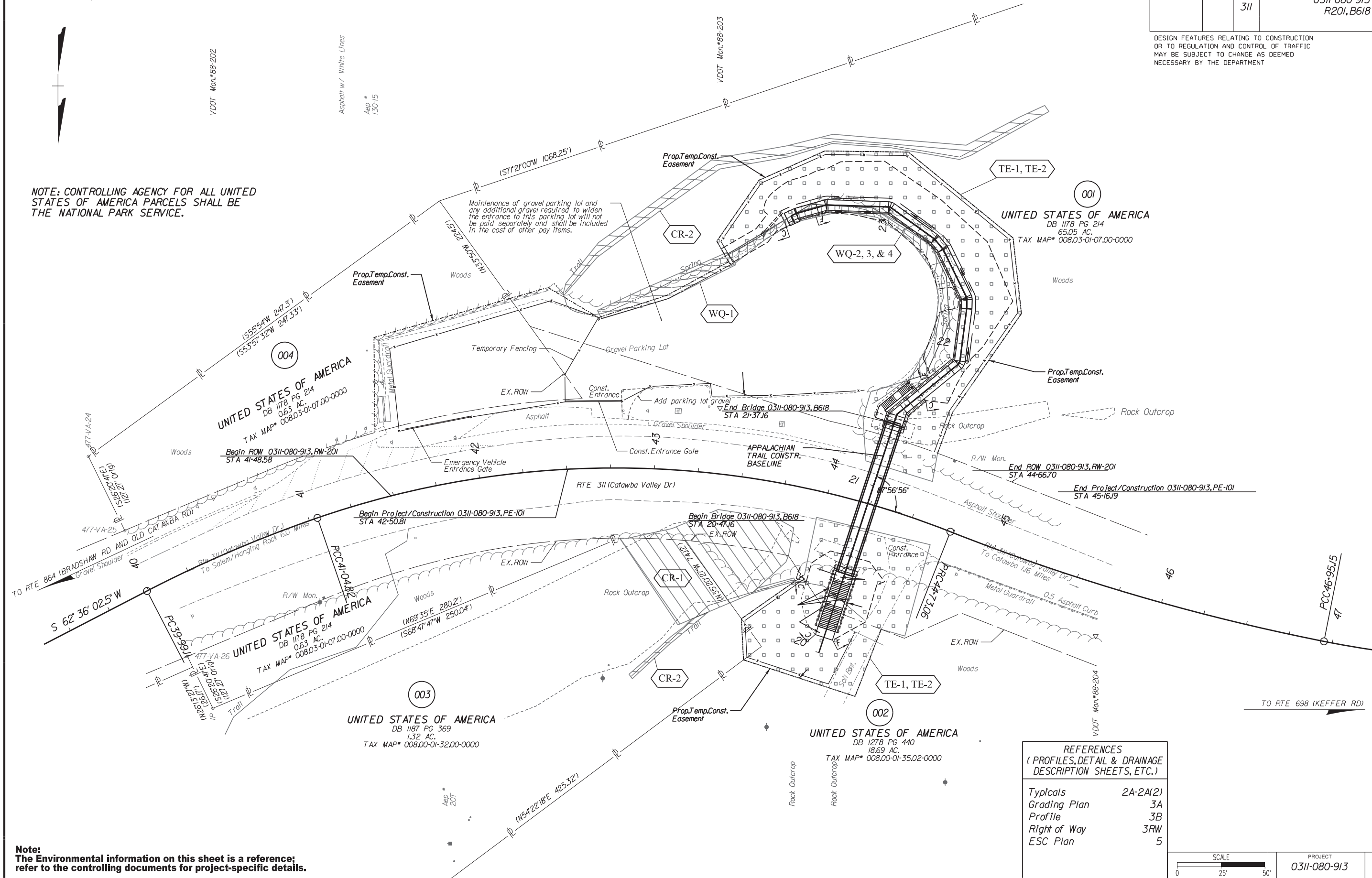

Note: The Environmental information on this sheet is a reference; refer to the controlling documents for project-specific details.

REFERENCES
(PROFILES, DETAIL & DRAINAGE DESCRIPTION SHEETS, ETC.)

Typicals	2A-2A(2)
Grading Plan	3A
Profile	3B
Right of Way	3RW
ESC Plan	5

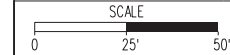

PROJECT	SHEET NO.
0311-080-913	3E(2)

PROJECT MANAGER LEONARD, GISINER, 540-387-5457, VDOT, SALEM DISTRICT
SURVEYED BY, DATE S.J. HOLLANDSWORTH, 11-15-18, 540-387-5227, VDOT, SALEM DISTRICT
DESIGN BY TRANSYSTEMS CORPORATION - (678) 244-9730
SUBSURFACE UTILITY BY, DATE N/A

ENVIRONMENTAL COMMITMENTS SUMMARY

REVISED	STATE	ROUTE	STATE PROJECT	SHEET NO.
	VA.	311	0311-080-913 R201, B618	3E

DESIGN FEATURES RELATING TO CONSTRUCTION OR TO REGULATION AND CONTROL OF TRAFFIC MAY BE SUBJECT TO CHANGE AS DEEMED NECESSARY BY THE DEPARTMENT

Project Number: 0311-080-913
UPC: 111068
AssocProjects(UPC): 00311080-24725160

avoidance to document that only permitted activities are taking place. The checklist shall be completed in its entirety for each monthly inspection and shall be kept on site and available for review by VDEQ.

Environmental Commitments

PRE-CONSTRUCTION

Water Quality Permits

Commitment Name: Flagging of Waters of the US (WOTUS) <WQ1>
Description: The Permittee (Area Construction Engineer) in coordination with the District Environmental Manager shall ensure that the following activities are accomplished prior to commencement of construction: notification to VDEQ that construction is planned to commence in permit authorized areas; flagging of surface waters in the project area where construction activities are permitted and not permitted to occur; and pre-construction photographs taken of all permitted impact sites.
Refer to Page: 3

CONSTRUCTION

Cultural Resources

Commitment Name: Avoidance of historic property <CR1>
Description: An archaeological site (Native American Rockshelter) is located near the north abutment at approximately STA 43+25 to 43+75. The site was determined to be not eligible for the National Register of Historic Places (NRHP) pursuant to Sec. 106 of the NHPA; however, it is still an NPS-owned visitor resource for which all impacts (direct and indirect - vibratory/percussive) should be avoided.
Refer to Page: 3

Commitment Name: Avoidance of historic property <CR2>

Description: The Appalachian Trail (AT) is eligible for the NRHP and is considered a Sec.4(f) property. Design considerations have been coordinated with appropriate regulatory and sponsoring agencies and should be considered design constraints. Any construction revisions or contractor use of the active AT trail segment through the project area should be avoided.
Refer to Page: 3

Water Quality Permits

Commitment Name: Completion of VDEQs monthly VWP Permit Inspection Checklist <WQ2>
Description: The Permittee (Area Construction Engineer) or his designee shall complete VDEQ's Monthly VWP Permit Inspection Checklist once every calendar month during activities within permitted impact areas. Inspections shall include all permitted impact sites and adjacent waters previously flagged for

December 1, 2022, 03:13:50 PM

Page 1 of 3

Commitment Name: Compliance with water quality permits <WQ3>

Description: All personnel involved in construction activities shall read and understand the SPGPWP3 permit requirements; and all permit conditions (project specific, regional and general) shall be complied with during construction. If there are any proposed revisions in the permitted activities or plan of operations affecting the stream then the Environmental Section shall be contacted to determine if a permit modification is necessary prior to the revised instream activities taking place.
Refer to Page: 3

Threatened and Endangered Species

Commitment Name: Protection of Loggerhead Shrike - brush and tree removal limitations <TE1>

Description: Removal or brush and trees less than 30cm located within the project limits (Limits of Disturbance and easements) shall take place outside of the time-of-year restriction of 4/1 - 7/31 of any year.

Commitment Name: Protection of bat species - Tree trimming and removal limitations <TE2>

Description: In accordance with the Special Provision for Tree Removal Time of Year Restriction for Roosting Bat Habitat, 0.3 acres of trees greater than or equal to 3 inch DBH and located within the project limits (Limits of disturbance or easements) shall be trimmed or removed outside of the time of year restriction of 4/1 - 11/14.

POST CONSTRUCTION

Water Quality Permits

Commitment Name: Seed Mix Limitations <WQ4>

Description: In accordance with the State Programmatic General Permit special conditions, seed mixes used on disturbed areas which result from the execution of jurisdictional impacts authorized by a Army Corps of Engineers Nationwide Permit shall not include invasive species (i.e. crown vetch).

Commitment Name: Submittal of termination notice to VDEQ for WP3 permit upon completion of permitted activities <WQ5>

December 1, 2022, 03:13:50 PM

Page 2 of 3

Name:
Description: The Permittee (Area Construction Engineer (ACE) shall advise the Environmental Section upon completion of the permit authorized activities. The Environmental Section will complete the following activities: review the project; prompt the ACE to sign the termination notice; and subsequently submit the termination notice to VDEQ on behalf of the ACE within 30 days of completion of the permit authorized activities.

Water Quality Permits Information			
DEQ Permit Issuance Date:	11/14/2022	Permit #:	22-4101
DEQ Reporting Date:	10/31/2022		
COE:	22-SPGP-LT		
VDEQ:	VWP General Permit No. WP3		
VMRC:			

December 1, 2022, 03:13:50 PM

Page 3 of 3

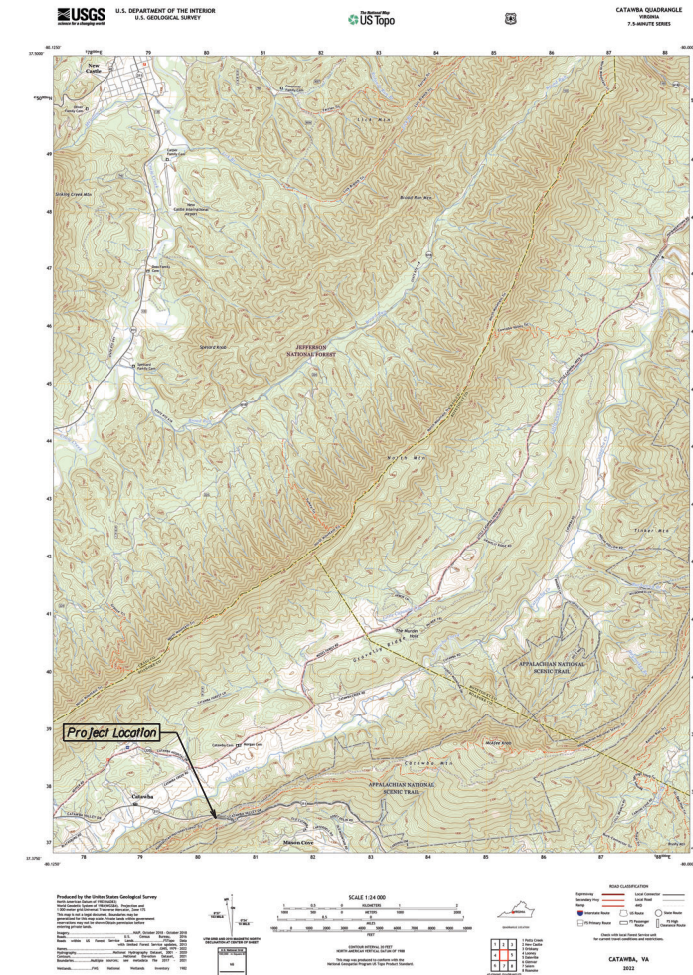

Environmental Contacts

District Environmental Manager:
Robin Simpson
(540) 312-3604
Robin.Simpson@vdot.virginia.gov

Environmental Commitments Inspector:
Isaac Jones
(540) 580-0549
Isaac.Jones@vdot.virginia.gov

- Abbreviations:**
- ACM - Asbestos Containing Materials
 - BMP - Best Management Practice
 - CR- Cultural Resources
 - DEM - District Environmental Manager
 - ECI - Environmental Commitment Inspector
 - VDGIF - Department of Game and Inland Fisheries
 - FHWA - Federal Highway Administration
 - MOA - Memorandum of Agreement
 - MOU - Memorandum of Understanding
 - NEPA - National Environmental Policy Act
 - NOI - Notice of Intent
 - NWP - Nationwide Permit
 - TOYR - Time of Year Restriction
 - T&E - Threatened and Endangered Species
 - PCN - Pre-Construction Notification
 - VDEQ - Virginia Department of Environmental Quality
 - VMRC - Virginia Marine Resources Commission
 - USACE/COE - U.S. Army Corps of Engineers
 - USFWS - U.S. Fish and Wildlife Service
 - WOTUS - Waters of the United States
 - WO - Water Quality

Notes:
Information on this sheet is a reference document related to the Environmental Commitments, Conditions and Clearances applicable to this project. Refer to the controlling documents (Bid/Proposal/Contract Special Provisions, Final Construction Plans, etc.)

Environmental shall be contacted regarding any field adjustments, construction Plan revisions, etc. prior to work proceeding to allow review to verify environmental compliance.

PROJECT	SHEET NO.
0311-080-913	3E

PROJECT MANAGER LEONARD, GISINER, 540-387-5457, VDOT, SALEM DISTRICT
SURVEYED BY, DATE S.L. HOLLANDSWORTH, 11-15-18, 540-387-5227, VDOT, SALEM DISTRICT
DESIGN BY TRANSYSTEMS CORPORATION - (678) 244-9730
SUBSURFACE UTILITY BY, DATE N/A

RIGHT OF WAY PLAN SHEET SHOWING PROPOSED TEMPORARY EASEMENTS ON PROPERTY OF U.S.A Conveyed by Deed to The COMMONWEALTH OF VIRGINIA

	REVISED	STATE	ROUTE	STATE PROJECT	SHEET NO.
		VA.	311	0311-080-913- PE-101, C-501, RW-201	3RW-1
DESIGN FEATURES RELATING TO CONSTRUCTION OR TO REGULATION AND CONTROL OF TRAFFIC MAY BE SUBJECT TO CHANGE AS DEEMED NECESSARY BY THE DEPARTMENT					
VDOT Location & Design Salem, Virginia Land Surveyor					

Proposed Temporary Easement for Parcel 001 (25961 Sq.Ft.)

Metes and Bounds:

Beginning at a point on the south right of way of Route 311, being a point at Station 42+35.74 and Offset 82.60 feet left from Route 311 Construction Baseline; thence leaving Route 311 S35°50'29"E, a distance of 19.64 feet to a point; thence S73°58'26"W, a distance of 22.59 feet to a point; thence N59°08'28"W, a distance of 33.43 feet to a point; thence S72°00'53"W, a distance of 41.06 feet to a point; thence S61°25'57"W, a distance of 39.98 feet to a point; thence S30°00'25"E, a distance of 13.53 feet to a point; thence S34°42'36"W, a distance of 42.29 feet to a point; thence S66°00'29"W, a distance of 40.91 feet to a point; thence N89°15'35"W, a distance of 47.73 feet to a point; thence N50°35'46"W, a distance of 77.13 feet to a point; thence N06°16'01"W, a distance of 43.34 feet to a point; thence N34°52'34"E, a distance of 68.52 feet to a point; thence N20°10'20"E, a distance of 24.86 feet to a point on the south right of way of Route 311; thence along the south right of way of Route 311, a curve to the left with a Radius of 517.35 feet, an Arc Length of 64.52 feet, a Chord Bearing of S73°24'03"E, and a Chord Length of 64.48 feet to a point; thence S72°26'30"E, a distance of 178.60 feet to the Point of Beginning, containing 25961 Square Feet.

Proposed Temporary Easement for Parcel 002 (3030 Sq.Ft.)

Metes and Bounds:

Beginning at a point on the north right of way of Route 311, being a point at Station 43+96.31 and Offset 49.42 feet right from Route 311 Construction Baseline; thence along the right of way of Route 311 N33°47'33"W, a distance of 20.81 feet to a point; thence N68°45'20"W, a distance of 35.84 feet to a point; thence leaving the right of way of Route 311 N21°14'40"E, a distance of 40.99 feet to a point; thence S71°53'12"E, a distance of 66.87 feet to a point; thence S53°13'44"W, a distance of 12.76 feet to a point; thence S35°50'29"E, a distance of 19.50 feet to a point; thence S54°59'05"W, a distance of 42.28 feet to the Point of Beginning, containing 3030 Square Feet.

Proposed Temporary Easement for Parcel 003 (124 Sq.Ft.)

Metes and Bounds:

Commencing at a point on the north right of way of Route 311, being a point at Station 43+96.31 and Offset 49.42 feet right from Route 311 Construction Baseline; thence leaving the north right of way of Route 311 N54°59'05"E, a distance of 42.28 feet to the Point of Beginning; thence N35°50'29"W, a distance of 19.50 feet to a point; thence N53°13'44"E, a distance of 12.76 feet to a point; thence S02°55'40"E, a distance of 23.47 feet to the Point of Beginning, containing 124 Square Feet.

Proposed Temporary Easement for Parcel 004 (5591 Sq.Ft.)

Metes and Bounds:

Beginning at a point on the south right of way of Route 311, being a point at Station 41+48.58 and Offset 37.25 feet left from Route 311 Construction Baseline; thence leaving the right of way of Route 311 S00°34'38"E, a distance of 54.12 feet to a point; thence S73°58'26"W, a distance of 80.58 feet to a point; thence N35°50'29"W, a distance of 70.37 feet to a point on the south right of way of Route 311; thence along the south right of way of Route 311 a curve to the left with a Radius of 517.41 feet, an Arc Length of 119.94 feet, a Chord Bearing of N80°42'26"E, and a Chord Length of 119.67 feet to the Point of Beginning, containing 5591 Square Feet.

SCALE 	PROJECT 0311-080-913	SHEET NO. 3RW-1
-----------	-------------------------	--------------------

PROJECT MANAGER LEONARD, GISINER, 540-387-5457, VDOT, SALEM DISTRICT
 SURVEYED BY, DATE S.L. HOLLANDSWORTH, 11-15-18, 540-387-5227, VDOT, SALEM DISTRICT
 DESIGN BY TRANSYSTEMS, CORPORATION, (678) 244-9730
 SUBSURFACE UTILITY BY, DATE N/A

SIGNING & MARKING PLANS

Alexander Stone
Lic. No. 0402061165
PROFESSIONAL ENGINEER

TranSystems
Richmond, Virginia
ROADWAY ENGINEER

REVISED	STATE	ROUTE	STATE PROJECT	SHEET NO.
	VA.	311	0311-080-913 R201, B618	4(2)

DESIGN FEATURES RELATING TO CONSTRUCTION OR TO REGULATION AND CONTROL OF TRAFFIC MAY BE SUBJECT TO CHANGE AS DEEMED NECESSARY BY THE DEPARTMENT

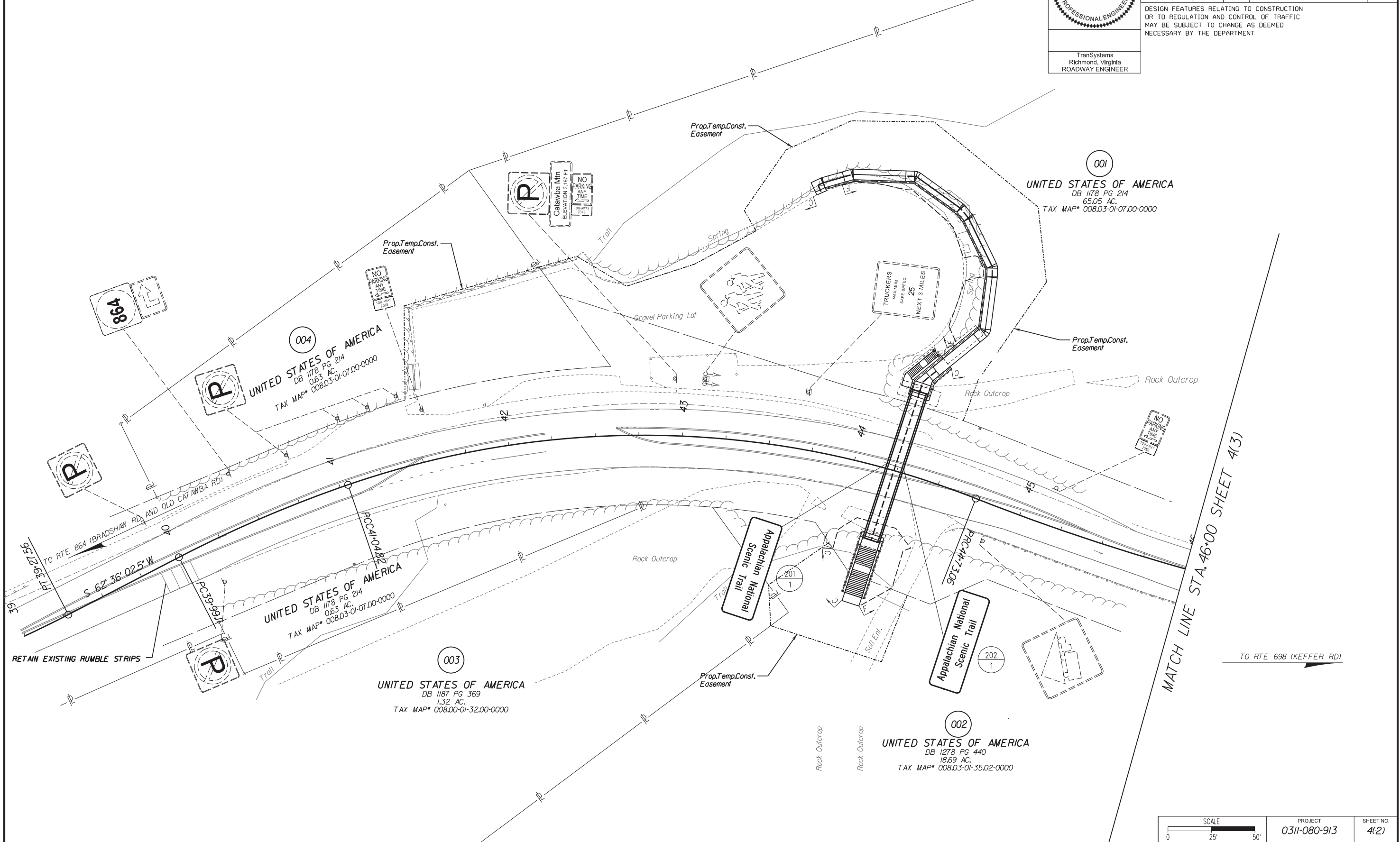

PROJECT MANAGER LEONARD, GISINER, 540-387-5457, VDOT, SALEM DISTRICT
 SURVEYED BY, DATE S.L. HOLLANDSWORTH, 11-15-18, 540-387-5227, VDOT, SALEM DISTRICT
 DESIGN BY TRANSYSTEMS, CORPORATION, (678) 244-9730
 SUBSURFACE UTILITY BY, DATE N/A

SIGNING & MARKING PLANS

Alexander Stone
Lic. No. 0402061165
PROFESSIONAL ENGINEER

TranSystems
Richmond, Virginia
ROADWAY ENGINEER

REVISED	STATE	ROUTE	STATE PROJECT	SHEET NO.
	VA.	311	0311-080-913 R201, B618	4(3)

DESIGN FEATURES RELATING TO CONSTRUCTION OR TO REGULATION AND CONTROL OF TRAFFIC MAY BE SUBJECT TO CHANGE AS DEEMED NECESSARY BY THE DEPARTMENT



TO RTE 655 (OAKLEY DOLIN RD)

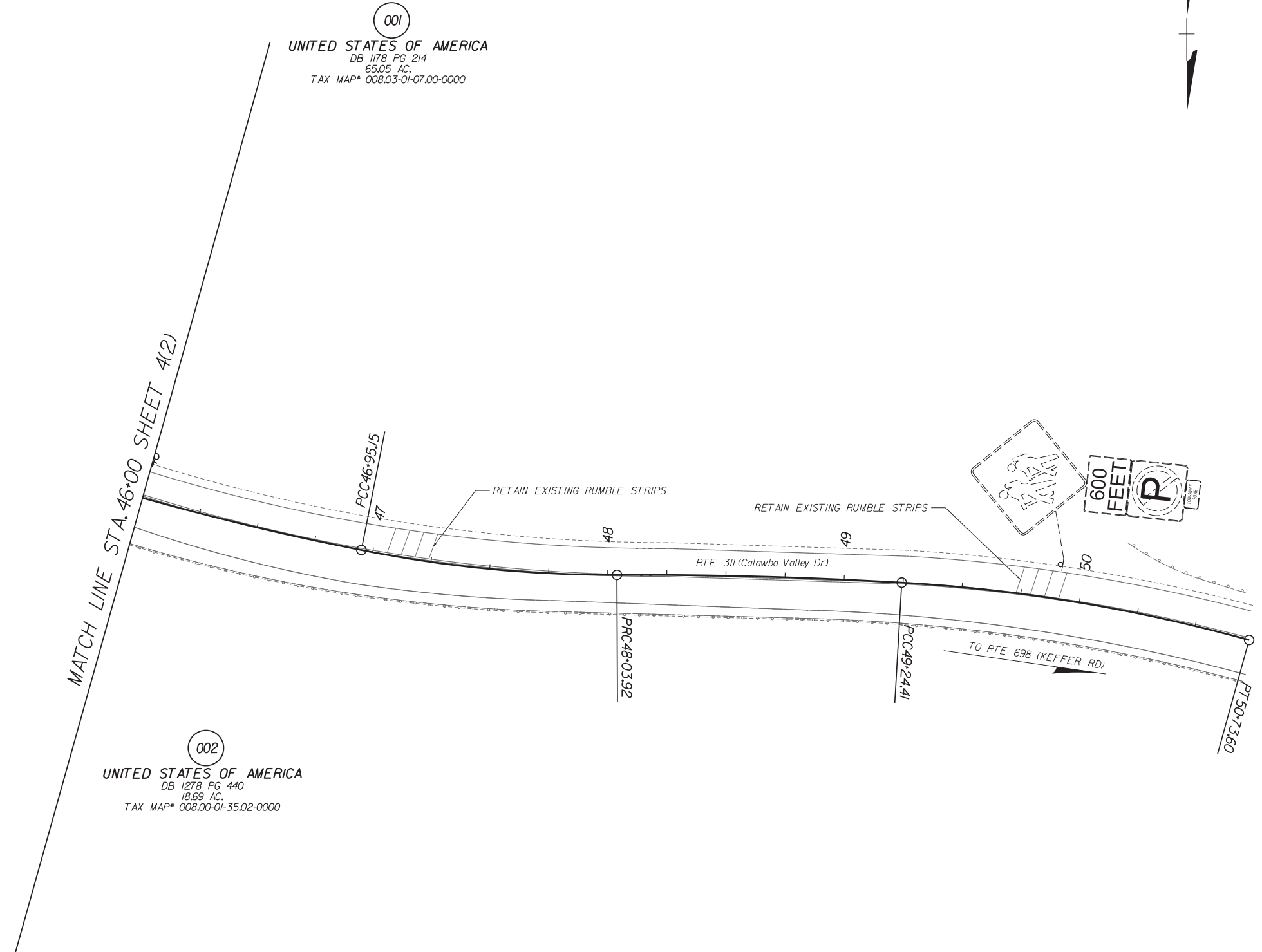

<p>SCALE</p>	<p>PROJECT</p> <p>0311-080-913</p>	<p>SHEET NO.</p> <p>4(3)</p>
--------------	------------------------------------	------------------------------

PROJECT MANAGER LEONARD, GISINER, 540-387-5457, VDOT, SALEM DISTRICT
 SURVEYED BY, DATE S.L. HOLLANDSWORTH, 11-15-18, 540-387-5227, VDOT, SALEM DISTRICT
 DESIGN BY TRANSYSTEMS CORP., (843) 266-9300
 SUBSURFACE UTILITY BY, DATE N/A

EROSION AND SEDIMENT CONTROL PLAN

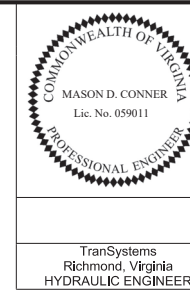

REVISED	STATE	ROUTE	STATE PROJECT	SHEET NO.
	VA.	311	0311-080-913 R201, B618	5

DESIGN FEATURES RELATING TO CONSTRUCTION OR TO REGULATION AND CONTROL OF TRAFFIC MAY BE SUBJECT TO CHANGE AS DEEMED NECESSARY BY THE DEPARTMENT

TranSystems
Richmond, Virginia
HYDRAULIC ENGINEER

- EROSION AND SEDIMENT CONTROL PLAN NOTES:**
1. THE CONTRACTOR SHALL LIMIT ALL DISTURBANCES TO WITHIN THE PROJECT LIMITS. THIS PROJECT IS UNDER 1 ACRE OF DISTURBANCE AND DOES NOT REQUIRE A VPDES PERMIT.
 2. CLEAR AND GRUB ONLY AREAS NECESSARY FOR PERIMETER EROSION AND SEDIMENT CONTROL SILT FENCE, TOE DITCHES AND STABILIZED CONSTRUCTION ENTRANCES.
 3. CONSTRUCT AND INSTALL PERIMETER SILT FENCE CONTROLS.
 4. INSTALL STABILIZED CONSTRUCTION ENTRANCES AT LOCATIONS TO BE APPROVED BY THE ENGINEER.
 5. CONSTRUCT NEW BRIDGE AND APPROACHES PER THE STAGED CONSTRUCTION SEQUENCE SHOWN ON THE TRANSPORTATION MANAGEMENT PLAN.

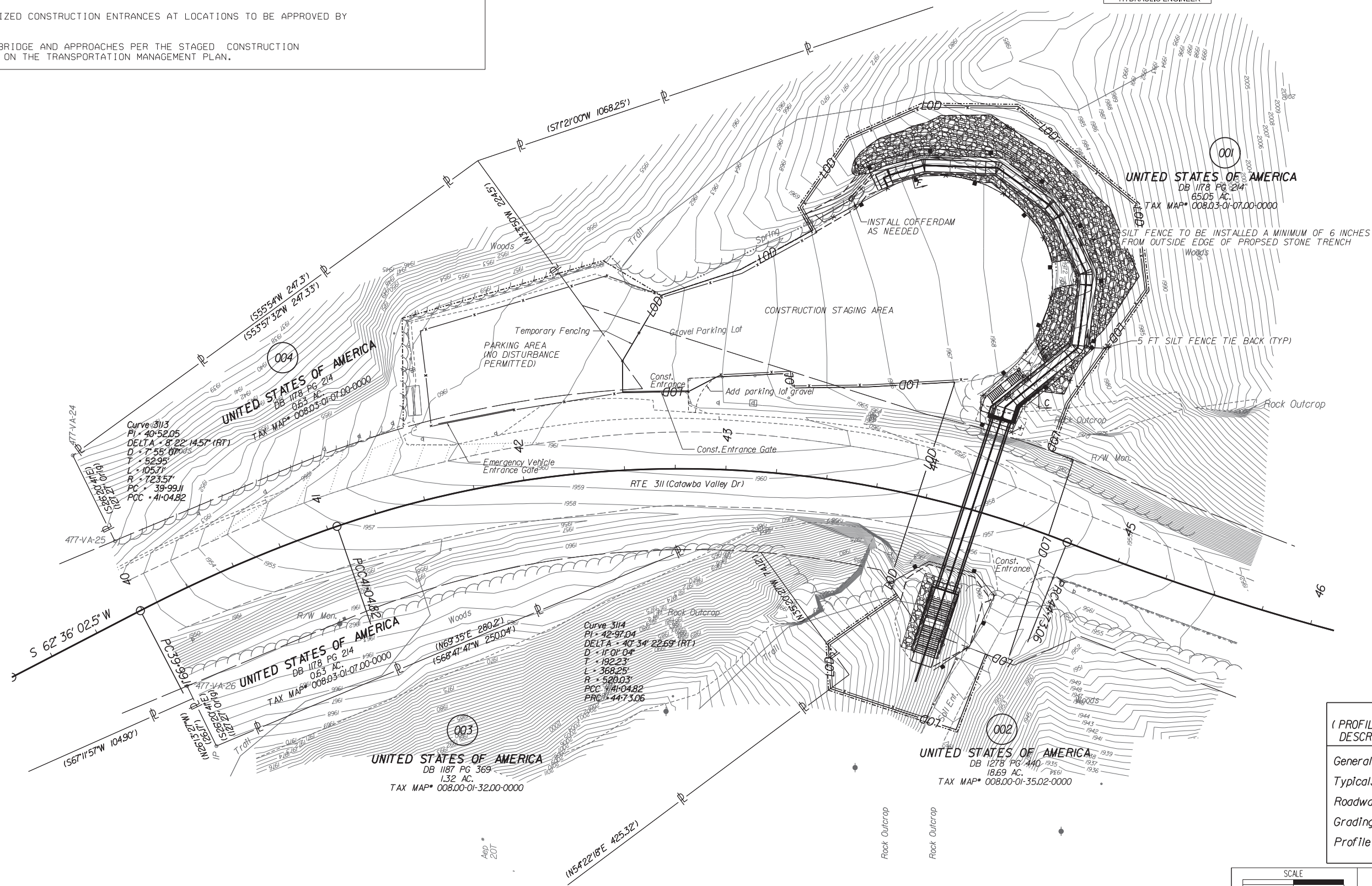

REFERENCES
(PROFILES, DETAIL & DRAINAGE DESCRIPTION SHEETS, ETC.)

General Notes	2
Typicals	2A-2A(2)
Roadway	3
Grading/Drainage	3A
Profile	3B

SCALE	PROJECT	SHEET NO.
0 25' 50'	0311-080-913	5

PROJECT MANAGER LEONARD, GISINER, 540-387-5457, VDOT, SALEM DISTRICT
SURVEYED BY, DATE S.L. HOLLANDS, NORTH, 11-15-18, 540-387-5227, VDOT, SALEM DISTRICT
DESIGN BY TRANSYSTEMS, CORP., (843) 266-9300
SUBSURFACE UTILITY BY, DATE N/A

STORMWATER POLLUTION PREVENTION PLAN (SWPPP) GENERAL INFORMATION SHEET

REVISED	STATE	ROUTE	STATE PROJECT	SHEET NO.
	VA.	311	0311-080-913 R201, B618	5A

DESIGN FEATURES RELATING TO CONSTRUCTION OR TO REGULATION AND CONTROL OF TRAFFIC MAY BE SUBJECT TO CHANGE AS DEEMED NECESSARY BY THE DEPARTMENT

The information contained in the SWPPP General Information sheets is intended to comply with the requirements of the VPDES General Permit For Discharges Of Stormwater From Construction Activities (the VPDES Construction Permit) issued July 1, 2019 and VDOT's approved Annual ESC and SWM Standards and Specifications.

The SWPPP General Information sheets are to be completed and included in the construction plan set (or other such documents) for land disturbance activities that disturb an area equal to or greater than 10,000 square feet outside the Chesapeake Bay Preservation Area, or equal to or greater than 2,500 square feet in the area defined as Tidewater, Virginia in the Virginia Chesapeake Bay Preservation Act.

The VDOT RLD (as defined in the latest IIM 242) will ensure that the information shown on the SWPPP General Information sheets is updated/revised as necessary in order to reflect changes that may occur during the construction phase of the land disturbing (construction) activity. The updated/revised sheets shall be maintained with the designated record set of plans (or other such documents) for the land disturbance (construction) activity.

XX 4. The location of on-site support facilities that will be covered under the VPDES Construction Permit coverage for this land disturbance (construction) activity shall be provided by the contractor and identified on the record set of plans or in other appropriate contract documents. Support facilities shall include, but not be limited to, borrow and disposal areas, construction and waste material storage areas, equipment and vehicle washing, maintenance, storage and fueling areas, storage areas for fertilizers, fuels or chemicals, concrete wash out areas, sanitary waste facilities and any other areas that may generate a stormwater or non-stormwater discharge directly related to the construction site.

XX 5. Written Evidence of permit coverage shall be provided by the contractor for all support activities located outside of VDOT right of way or easement in the form of the Construction General Permit coverage letter.

6. List the surface waters that have been identified as impaired in the DEQ 2020 305(b)/303(d) Water Quality Assessment Integrated Report for sediment, total suspended solids, turbidity, Nitrogen or Phosphorus. These pollutants are considered benthic impairments:
N/A

7. Identify the TMDL's where stormwater from construction activities discharges into a watershed with a TMDL waste load allocation established and approved by the State Water Control Board prior to July 1, 2016 for sediment, total suspended solids, turbidity, nitrogen or phosphorus:
N/A

8. This land disturbance activity discharges stormwater to the following surface waters that have been identified as exceptional in Section 9VAC25-260-30 A 3 c of the Virginia Administrative Code:
N/A

9. Locations of surface waters and locations where concentrated stormwater is discharged from this land disturbance (construction) activity are identified in the construction plan set (or other such documents) for this land disturbance (construction) activity.

10. The ESC and SWM plans (where applicable) for this land disturbance (construction) activity have been developed in accordance with VDOT's Approved Annual Erosion and Sediment Control and Stormwater Management Standards and Specifications as approved by the DEQ.

11. List the RLD and other responsible parties for the land disturbance activity: (required for erosion and sediment control). The following individual(s) have "delegated authority" to sign all reports required by the construction permit including the SWPPP General Information Sheets and Inspection Reports (C-107). Reference form LD-445H for delegation of authority (form 445H for the project is hereby incorporated by reference into this SWPPP). These individual(s) has/have overall responsibility or the environmental matters for the project: (required only for permitted projects):

Name	Position	Responsibility
	RLD	Certify the SWPPP (with date & sig.)
	Certified Inspector	Sign (C-107) Inspection Form Part 1
	Certified Inspector	Sign (C-107) Inspection Form Part 2

X 12. The name of the VDOT individual(s) responsible for the oversight inspection in accordance with IIM-LD-256 on these land disturbance construction activities as identified on these SWPPP General Information Sheets. The names will be updated and maintained with the other SWPPP documents for this land disturbance activity.

VDOT Individuals	Position	Responsibility
Jeff Ferguson	NPDES	NPDES coordinator responsible for the oversight inspection in accordance with IIM-LD-256
Jay Crumpacker, PE	Dist. Hyd. Engineer	District Hydraulic Engineer or designee(s) responsible for the review & the coordination approval of ESC SWM plan modification(s).

X 13. The ESC and P2 inspections for this land disturbing (construction) activity shall follow Schedule 1 as defined in 2020 R&B Specifications except for Section 107.16(e)4. an Inspection Requirements Rain gauge notes apply only to Inspection Schedule 1.

XX 14. The location of the on-site rain gauge that will be used to determine the occurrence of a measurable storm event for the purposes of ESC and Pollution Prevention inspections will be provided by the contractor and identified on the record set of plans or in other appropriate SWPPP documents for this land disturbance activity:
(List location of rain gage).

The rain gage shall be observed daily at " _____ " to determine the occurrence of a measurable storm event (i.e., 0.25 inches of rainfall or greater in a 24 hour period). A log book shall be maintained to record observation information which shall include (1) the date, (2) the time, (3) whether or not rainfall is occurring at the time of the observation, (4) the amount of accumulated rainfall in the gage, if any, and (5) whether or not an inspection is required based on the amount of accumulated rainfall in the gage. If there is no rainfall occurring at the time of the observation, the observation information shall be noted in the log book and the rain gage emptied and replaced. An inspection is required if there is 0.25 inches or more accumulation noted in the rain gage. If there is rainfall occurring at the time of the observation, the observation information is to be noted in the log book. The rain gage is not to be emptied but left to accumulate additional rainfall until the conclusion of the rainfall event. At the conclusion of the rainfall event, an observation of the rain gage shall be made and the observation information shall be noted in the log book and the rain gage emptied and replaced. An inspection is required if there is 0.25 inches or more accumulation noted in the rain gage.

15. The following VDOT documents are applicable to a) permitted projects b) non-permitted projects in Chesapeake Bay Preservation Areas (CBPA) with 2,500 S.F. to 1.0 acre of land disturbance c) non-permitted projects requiring a SWPPP and d) Non-permitted, Non-CBPA with BMP projects that have a water quantity BMP:

- VDOT LD-445: Permitted projects, CBPA projects and Non-permitted, Non-CBPA with BMP projects that have a water quantity BMP and ESC projects > 10,000 s.f. but < 1 acre.
- VDOT LD-445A: Permitted projects only.
- VDOT LD-445C: Projects that require a permit, ESC Plan, or SWPPP.
- VDOT LD-445D: Permitted projects, CBPA projects and Non-permitted, Non-CBPA with BMP projects that have a water quantity BMP.
- VDOT LD-445F: Emergency work projects (when applicable).
- Water Quality Requirement (when applicable)
- VDOT LD-445H: Permitted projects only.
- VDOT C-107 Part I and Part II. All projects that require a permit or SWPPP.
- VDOT LD-445I: AS&S Approval Form (when applicable)

16. If there is an excessive loading of sediment from the project (i.e. more than to be expected from the project with an implemented ESC plan) that is discovered within a local watershed with a sediment TMDL that allocates a WLA to VDOT's MS4, (see note *7) the contractor shall investigate the area of concern at the site within 24 hours of discovery and ensure all erosion and sediment control best management practices are being implemented in accordance with the permits approved standards and specifications required by Part I.B of the current Construction General Permit. If corrective action is necessary, the contractor shall initiate corrective actions no later than 5 business days after the initial investigation.

17. If excessive loading of sediment from a land disturbing activity that is not the responsibility of the contractor is discovered discharging into a MS-4, the contractor shall notify the municipality with jurisdiction over erosion and sediment control activities.

X Denotes information that is to be provided/completed by the RLD.
XX Denotes information that is to be provided/completed by the contractor.

X I certify under penalty of law that I have read and understand this document and that this document and all attachments were prepared in accordance with a system designed to assure that qualified personnel properly gathered and evaluated the information submitted. Based on my inquiry of the person or persons who manage the system, or those persons directly responsible for gathering the information, the information submitted is, to the best of my knowledge and belief, true, accurate, and complete. I am aware that there are significant penalties for submitting false information, including the possibility of fine and imprisonment for knowing violations.

X I further certify that this document and all other documents related to the SWPPP, as identified on the SWPPP General Information Sheets, are maintained at the activity site, or at a location convenient to the activity site where no on-site facilities are available, and such documents will be made available for review upon request in accordance with the provisions of the General VPDES Permit for Discharges of Stormwater from Construction Activities (VAR10) when applicable. Where the SWPPP documents are not stored on-site, a copy of such documents shall be in the possession of those with day to day operational control over the implementation of the SWPPP whenever they are on site.

* or ** Delegated Authority Signature*

Signature: _____
Printed Name: _____
Date: _____

(1) See Section 1, Item 11 relating to delegation of authority, and form LD-445H (Delegation of Authority).

ACRONYMS

- | | |
|--|---|
| CBPA - Chesapeake Bay Preservation Act | SWPPP - Stormwater Pollution Prevention Plan |
| BMP - Best Management Practice | TMDL - Total Maximum Daily Load |
| DEQ - Department of Environmental Quality | VDOT - Virginia Department of Transportation |
| EPA - U.S. Environmental Protection Agency | VPDES - Virginia Pollutant Discharge Elimination System |
| ESC - Erosion and Sediment Control | VSMP - Virginia Stormwater Management Program |
| IIM - Instructional and Informational Memorandum | VESCP - Virginia Erosion and Sediment Control Program |
| R&B - Road and Bridge | WLA - Waste Load Allocation |
| RLD - Responsible Land Disturber | SWM - Stormwater Management |

SECTION I GENERAL INFORMATION

- Activity Description - This project consists of the construction of a pedestrian bridge over SR 311 and associated construction of approaches, walls, and pedestrian access points.
- This land disturbance (construction) activity site is located in Roanoke County and approximately 0.90 acres will be disturbed by excavation, grading or other construction activities.
- This proposed activity disturbs less than one acre and is exempt from coverage under the VPDES General Permit for Discharges Of Stormwater from Construction Activities (the VPDES Construction Permit) as issued by the DEQ.

Revised 5/1/19

PROJECT 0311-080-913	SHEET NO. 5A
-------------------------	-----------------

PROJECT MANAGER LEONARD, GISINER, 540-387-5457, VDOT, SALEM DISTRICT
SURVEYED BY, DATE S.L. HOLLANDS/NORTLH, 11-15-18, 540-387-5227, VDOT, SALEM DISTRICT
DESIGN BY TRANSYSTEMS, CORP. (843) 266-9300
SUBSURFACE UTILITY BY, DATE N/A

REVISED	STATE	ROUTE	STATE PROJECT	SHEET NO.
	VA.	311	0311-080-913 R201, B618	5B

SECTION II EROSION AND SEDIMENT CONTROL

- XX 1. The intended sequence and timing of activities that disturb soils at the site (e.g., grubbing, excavation, grading, utilities and infrastructure installation, etc.) shall be provided by the contractor in accordance with the current edition of Section 108.03 of the VDOT R&B Specifications and shall be included with the other SWPPP documents for this land disturbance (construction) activity.
- 2. Directions of stormwater flow and approximate slopes anticipated after major grading activities are identified in the construction plan set (or other such documents) for this land disturbance (construction) activity.
- 3. Areas of soil disturbance and areas of the site which will not be disturbed are identified in the construction plan set (or other such documents) for this land disturbance (construction) activity.
- 4. Locations of major structural and nonstructural ESC measures intended to filter, settle or similarly remove sediment are identified in the construction plan set (or other such documents) for this land disturbance (construction) activity.
- 5. Locations where stabilization practices are expected to occur are identified in the construction plan set (or other such documents) for this land disturbance (construction) activity.
- 6. A description of interim and permanent stabilization practices for the site are identified in the applicable sections of the documents identified in the Note 1 of Section IV.
- XX 7. A record of the dates when major grading activities occur, when construction activities temporarily or permanently cease on a portion of the site, and when stabilization measures are initiated will be provided by the contractor and maintained with the record set of plans or other SWPPP documents for this land disturbance (construction) activity: (List how this will be tracked and the location)
- 8. A description and schedule of procedures to maintain vegetation, erosion and sediment control measures and other protective measures in good and effective operating conditions are identified in the current edition of Sections 107.16 and 303.03 of the VDOT R&B Specifications.
- 9. Nutrients shall be applied in accordance with the current edition of Sections 603 and 604 of the VDOT Road and Bridge Specifications. Nutrients shall not be applied during rainfall events. Top soil shall be applied in accordance with the current edition of section 602 of the latest Road and Bridge Specifications.
- 10. All engineering calculations supporting the design of erosion and sediment control measures proposed for this land disturbance (construction) activity are contained in the project drainage file located in the VDOT Salem District Hydraulics Section and will be made available for review upon request during normal business hours.
- 11. The temporary erosion and siltation control items shown on the ESC Plan for this land disturbing (construction) activity are intended to provide a general plan for controlling erosion and sediment within the project limits. The ESC Plan is based on field conditions at the time of plan development and an assumed sequence of construction for the project. The contractor, in conjunction with the VDOT Project Engineer and/or ESC Inspector, shall adjust the location, quantity and type of erosion and sediment control items required based on the actual field conditions encountered at the time of construction and the actual scheduling and sequencing of the construction activities. Significant changes to the proposed ESC Plan (e.g., those that require an engineering analysis, elimination of a perimeter control, change to ESC concept that would affect the quantity or direction of flow of water) shall be submitted to the applicable District Hydraulics Engineer for review and approval. Any changes to the proposed ESC Plan must be noted on the designated record set of plans which shall be retained on the project site and made available upon request during normal business hours.
- 12. The areas beyond the project's construction limits are to be protected from siltation. Perimeter controls such as silt fence, diversion dikes, turbidity curtains, etc. shall be installed prior to any grubbing operations or other earth moving activities.
- 13. Temporary earthen structures such as dikes and berms are to be stabilized immediately upon installation. Stabilization may include temporary or permanent seeding, riprap, aggregate, sod, mulching, and/or soil stabilization blankets and matting in conjunction with seeding.
- 14. All channel relocations are to be constructed during the earliest stage of construction and shall be constructed in accordance with all applicable permit requirements and shall be constructed in the dry wherever possible. Stabilization or vegetation shall be established before flow is redirected through the constructed area as directed by the Engineer.
- 15. The contractor shall plan and implement his land disturbance operations in order to:
 - a. Control the volume and velocity of stormwater runoff within the site to minimize erosion.
 - b. Control the peak flow rates, volume and velocity of stormwater discharges to minimize erosion at outlets and in downstream channels.
 - c. Minimize the amount of soil exposed.
 - d. Minimize the disturbance of steep slopes.
 - e. Minimize sediment discharge from the site.
 - f. Provide and maintain natural buffers around surface waters, direct stormwater runoff to vegetated areas and maximize stormwater infiltration, unless infeasible.
 - g. Minimize soil compaction (except in those areas where compaction is required by the contract documents) and preserve topsoil where feasible.

- XX 16. The name of the individual(s) or contractor(s) responsible for the installation and maintenance of the erosion and sediment control measures shall be supplied by the contractor and maintained with the other SWPPP documents for this land disturbance (construction) activity.

17. Soil stockpiles temporarily placed within the project area or on VDOT right of way or easement shall be identified, stabilized, and protected with sediment trapping measures.

18. A construction entrance or other approved measure shall be installed at allocations where construction vehicular traffic access routes intersect a paved or a public road in order to minimize the transport of sediment by vehicular tracking onto the paved surface. Where sediment is transported onto a paved or a public road surface, the road shall be cleaned thoroughly at the end of each work day by shoveling or sweeping. Removed sediment shall be disposed of in accordance with Section 106.04 of the R&B Specifications.

19. Any variance, exception or deviation approved by DEQ must be listed below and supporting documentation (exception/variance/deviation request and DEQ approval) must be maintained with the SWPPP.

The following exceptions to the Water Quantity criteria of the VSMP Regulation have been approved by the DEQ for this land disturbance (construction) activity: (list all approved exceptions and include a brief description of the exception, the date approved and the approving DEQ Office)

Type(1)	Regulation Modified(2)	Approval Date(3)	Description of Variance

- (1) Type of modification (Variance from ESC regulations, or Deviation from published guidance)
- (2) Section of Regulation or Guidance Document Modified (e.g. ESC Min. Std. 15)
- (3) Date that variance/exception/deviation was approved by DEQ.

~~SECTION III POST CONSTRUCTION STORMWATER MANAGEMENT~~

~~This section is not applicable. See Section 1, note 2~~

~~1. This land disturbance activity utilizes the Part IIB technical criteria (i.e., Runoff Reduction Method, Energy Balance Equation, etc.) in Section 9VAC25-870-62 et seq. of the VSMP Regulations.~~

~~3. Any variance, exception or deviation approved by DEQ must be listed below and supporting documentation (exception/variance/deviation request and DEQ approval) must be maintained with the SWPPP.~~

~~The following exceptions to the Water Quantity criteria of the VSMP Regulation have been approved by the DEQ for this land disturbance activity: (list all approved exceptions and include a brief description of the exception, the date approved and the approving DEQ Office)~~

Type(1)	Regulation Modified(2)	Approval Date(3)	Description of Waiver

- (1) Type of modification (Variance, or Exception from SWM Regulations or Deviation from published guidance)
- (2) Section of Regulation or Guidance Document Modified (e.g. ESC Min. Std. 15)
- (3) Date that variance/exception/deviation was approved by DEQ.

~~4. The permanent onsite SWM facilities or offsite strategies proposed to meet the water quality/quantity requirements for this land disturbance (construction) activity are listed in Section VI.~~

DESIGN FEATURES RELATING TO CONSTRUCTION OR TO REGULATION AND CONTROL OF TRAFFIC MAY BE SUBJECT TO CHANGE AS DEEMED NECESSARY BY THE DEPARTMENT

~~5. A description of all post-construction stormwater management measures that will be installed during the construction process to control pollutants in stormwater discharges after construction operations have been completed is included in the construction plan set (or other such documents) for this land disturbance (construction) activity.~~

~~6. All engineering calculations supporting the design of the post-construction stormwater management measures for this land disturbance (construction) activity, including an explanation of the technical basis used to select the practices, are contained in the project drainage file located in the VDOT Salem District Hydraulics Section and will be made available for review upon request during normal working business hours.~~

ACRONYMS

- CBPA - Chesapeake Bay Preservation Act
- BMP - Best Management Practice
- DEQ - Department of Environmental Quality
- EPA - U.S. Environmental Protection Agency
- ESC - Erosion and Sediment Control
- IIM - Instructional and Informational Memorandum
- R&B - Road and Bridge
- RLD - Responsible Land Disturber
- SWPPP - Stormwater Pollution Prevention Plan
- TMDL - Total Maximum Daily Load
- VDOT - Virginia Department of Transportation
- VPDES - Virginia Pollutant Discharge Elimination System
- VSMP - Virginia Stormwater Management Program
- VESCP - Virginia Erosion and Sediment Control Program
- WLA - Waste Load Allocation
- SWM - Stormwater Management

* Denotes information that is to be provided/ completed by the RLD.

XX Denotes information that is to be provided/completed by the contractor.

Revised 5/1/19

PROJECT	SHEET NO.
0311-080-913	5B

PROJECT MANAGER LEONARD, GISINER, 540-387-5457, VDOT, SALEM DISTRICT
SURVEYED BY, DATE S.L. HOLLANDS, NORTH, 11-15-18, 540-387-5227, VDOT, SALEM DISTRICT
DESIGN BY TRANSYSTEMS, CORP., (843) 266-9300
SUBSURFACE UTILITY BY, DATE WZA

STORMWATER POLLUTION PREVENTION PLAN (SWPPP) GENERAL INFORMATION SHEET

REVISED	STATE	STATE		SHEET NO.
		ROUTE	PROJECT	
	VA.	311	0311-080-913 R201, B618	5C

DESIGN FEATURES RELATING TO CONSTRUCTION OR TO REGULATION AND CONTROL OF TRAFFIC MAY BE SUBJECT TO CHANGE AS DEEMED NECESSARY BY THE DEPARTMENT

The information contained in the SWPPP General Information sheets is intended to comply with the requirements of the VPDES General Permit For Discharges Of Stormwater From Construction Activities (the VPDES Construction Permit) issued July 1, 2019 and VDOT's approved Annual ESC and SWM Standards and Specifications.

The SWPPP General Information sheets are to be completed and included in the construction plan set (or other such documents) for land disturbance (construction) activities that disturb an area equal to or greater than 10,000 square feet outside the Chesapeake Bay Preservation Area, or equal to or greater than 2,500 square feet in the area defined as Tidewater, Virginia in the Virginia Chesapeake Bay Preservation Act.

The VDOT RLD will ensure that the information shown on the SWPPP General Information sheets is updated/revised as necessary in order to reflect changes that may occur during the construction phase of the land disturbing (construction) activity. The updated/revised sheets shall be maintained with the designated record set of plans (or other such documents) for the land disturbance (construction) activity.

SECTION IV SWPPP

1. All documents related to the SWPPP for this land disturbance (construction) activity shall be maintained at the activity site and shall be readily available for review upon request during normal business hours. Such documents include, but are not limited to, the construction plans (or other such documents), the ESC Plan, the Pollution Prevention Plan, the post construction SWM Plan (if applicable), the VDOT R&B Standards and Specifications, Supplemental Specifications, Special Provisions and Special Provision Copied Notes. Documents related to stormwater pollution prevention which are not a part of those documents referenced above, such as copies of the VPDES Construction Permit coverage letter (when applicable) and the VPDES General Permit For Discharges Of Stormwater From Construction Activities (when applicable) and those required to be developed by the contractor for pollution prevention associated with any on-site support facilities being included in the VPDES Construction Permit coverage for this land disturbance (construction) activity are to be maintained at the activity site with the other SWPPP documents for this land disturbance (construction) activity. Where no facilities are available at the activity site to maintain the SWPPP documents, they are to be kept by or with the designated RLD at a location convenient to the activity site where they would be made available for review upon request during normal business hours.

2. The SWPPP and any subsequent amendments, modifications and updates shall be implemented from commencement of land disturbance until termination of VPDES Construction Permit coverage or completion of land disturbance (construction) activities where no VPDES Construction Permit coverage is required.

✖✖ 3. For all on-site support facilities that will be included in the VPDES Construction Permit coverage for this land disturbance (construction) activity, the contractor shall develop a SWPPP in accordance with, but not limited to, Section 106.08, 107.02 and 107.16 of the VDOT Road and Bridge Specifications. The SWPPP for the on-site support facilities shall be maintained with and become a component of the SWPPP for this land disturbance (construction) activity. Support facilities shall include, but not be limited to, borrow and disposal areas, construction and waste material storage areas, equipment and vehicle washing, maintenance, storage and fueling areas, storage areas for fertilizers, fuels or chemicals, concrete wash out areas, sanitary waste facilities and any other areas that may generate a stormwater or non-stormwater discharge directly related to the construction site.

4. For those land disturbing (construction) activities requiring coverage under the VPDES Construction Permit, the SWPPP shall be made available for review upon the request of the DEQ, the EPA, the VSMP Authority, the VESCP Authority, local government officials or the operator of a municipal separate storm sewer system (MS4) receiving discharge from the construction site.

✖ 5. For those land disturbing (construction) activities requiring coverage under the VPDES Construction Permit, the VDOT RLD shall post, or have posted, a copy of the General Permit coverage letter and a copy of a completed LD-445A form, noting the name and contact information for the VDOT person responsible for the land disturbing (construction) activity and its SWPPP, outside the project's construction office along with other Federal and State mandated information. Where there is no construction office (e.g., a maintenance activity), the permit coverage letter and the LD-445A form are to be maintained with the other SWPPP documents for the land disturbing (construction) activity.

6. The SWPPP shall be made available for review by the public upon request. Such reviews shall be at a time and publicly accessible location convenient to the VDOT and shall be scheduled during normal business hours and no less than once per month.

SECTION V - POLLUTION PREVENTION PLAN

- The following non-stormwater discharges from this land disturbing (construction) activity and any on-site support facilities are prohibited:
 - Wastewater from concrete washouts.
 - Wastewater from the washout and cleanout of stucco, paint, from release oils, curing compounds and other construction materials.
 - Fuels, oils or other pollutants used in vehicle and equipment operation and maintenance.
 - Oils, toxic substances or hazardous substances from spills or other releases.
 - Soaps, solvents or detergents used in equipment and vehicle washing.
 - There shall be no discharge of floating solids or visible foam in other than trace amounts.
- The following non-stormwater discharges from this land disturbing (construction) activity and any on-site support facilities are allowed when discharged in compliance with the VPDES Construction Permit:
 - Discharges from firefighting activities.
 - Fire hydrant flushings.
 - Waters used to wash vehicles or equipment where soaps, solvents or detergents have not been used and the wash water has been filtered, settled or similarly treated prior to discharge.
 - Water used to control dust that has been filtered, settled or similarly treated prior to discharge.
 - Potable water sources including uncontaminated waterline flushings managed in a manner to avoid stream impacts.
 - Routine external building wash down where soaps, solvents or detergents have not been used and the wash water has been filtered, settled or similarly treated prior to discharge.
 - Pavement wash waters where spills or leaks of toxic or hazardous materials have not occurred (or where all spilled or leaked material has been removed prior to washing), where soaps, solvents or detergents have not been used and where the wash water has been filtered, settled or similarly treated prior to discharge.
 - Uncontaminated air conditioning or compressor condensate.
 - Uncontaminated ground water or spring water.
 - Foundation or footing drains where flows are not contaminated with process materials such as solvents.
 - Uncontaminated excavation dewatering, including dewatering trenches and excavations that have been filtered, settled or similarly treated prior to discharge.
 - Landscape irrigation.

✖✖ 3. The contractor shall develop a Pollution Prevention Plan to address any of his on-site operations that have a potential to generate a pollutant that may reasonably be expected to affect the quality of stormwater discharges from this land disturbance (construction) activity. The Pollution Prevention Plan shall be developed in accordance with, but not limited to, Sections 106.08, 107.02 and 107.16 of the VDOT Road and Bridge Specifications and shall include a narrative with appropriate plan detail and shall be provided on standard 8.5 x 11 inch paper or larger and shall:

- Identify the potential pollutant-generating activities and the pollutant that is expected to be exposed to stormwater.
- Describe the location where the potential pollutant-generating activities will occur, or if identified on the record set of plans, reference the record set of plans.
- Identify all non-stormwater discharges, as described in note two of this section, that are or will be commingled with stormwater discharges from the construction activity, including any on-site support activities.
- Identify the person(s) or contractor(s) responsible for implementing and maintaining the pollution prevention practice or practices for each pollutant-generating activity.
- Describe the pollution prevention practices and procedures that will be implemented to:
 - Prevent and respond to leaks, spills, and other releases, including procedures for expeditiously stopping, containing, and cleaning up spills, leaks, and other releases, and procedures for reporting leaks, spills, and other releases in accordance with Section 107.16 of the VDOT Road and Bridge Specifications and the requirements within the VPDES Construction Permit.

- Prevent the discharge of spilled and leaked fuels and chemicals from vehicle fueling and maintenance activities.
- Prevent the discharge of soaps, solvents, detergents, and wash water from construction materials, including procedures for the clean-up of stucco, paint, form release oils, and curing compounds.
- Minimize the discharge of pollutants from vehicle and equipment washing, wheel wash water, and other types of washing.
- Direct concrete wash water into a leak-proof container or leak-proof settling basin. The container or basin shall be designed so that no overflows can occur due to inadequate sizing or precipitation. Hardened concrete wastes shall be removed and disposed of in a manner consistent with the handling of other construction wastes. Liquid concrete wastes shall be removed and disposed of in a manner consistent with the handling of other construction wash waters and shall not be discharged to surface waters.
- Minimize the discharge of pollutants from storage, handling, and disposal of construction products, materials, and wastes including building products (such as asphalt sealants, copper flashing, roofing materials, adhesives, and concrete admixtures), pesticides, herbicides, insecticides, fertilizers, landscape materials, construction and domestic wastes (such as packaging materials), scrap construction materials, masonry products, timber, pipe and electrical cuttings, plastics, styrofoam, concrete, and other trash or building materials.
- Prevent the discharge of fuels, oils, and other petroleum products, hazardous or toxic wastes, waste concrete and sanitary wastes.
- Address any other discharge from any potential pollutant-generating activity not listed herein.
- Minimize the exposure of waste materials to precipitation by closing or covering waste containers during precipitation events and at the end of the business day, or implementing other similarly effective practices. Minimization of exposure is not required in case where the exposure to precipitation will not result in a discharge of pollutants.
- Describe and implement procedures for providing pollution prevention awareness (including but not limited to prevention practices, disposal practices and appropriate disposal locations) for all applicable wastes (including any wash water), to appropriate personnel.

✖ Denotes information that is to be provided/completed by the RLD.

✖✖ Denotes information that is to be provided/completed by the contractor.

Revised 5/1/19

PROJECT	SHEET NO.
0311-080-913	5C

PROJECT MANAGER LEONARD, GISINER, 540-387-5457, VDOT, SALEM DISTRICT
SURVEYED BY, DATE S.L. HOLLANDS WORTH, 11-15-18, 540-387-5227, VDOT, SALEM DISTRICT
DESIGN BY TRANSYSTEMS, CORP., (843) 266-9300
SUBSURFACE UTILITY BY, DATE N/A

STORMWATER POLLUTION PREVENTION PLAN (SWPPP) GENERAL INFORMATION SHEET

REVISED	STATE	ROUTE	STATE PROJECT	SHEET NO.
	VA.	311	0311-080-913 R201, B618	5D

The information contained in the SWPPP General Information sheets is intended to comply with the requirements of the VPDES General Permit For Discharges Of Stormwater From Construction Activities (the VPDES Construction Permit) issued July 1, 2019 and VDOT's approved Annual ESC and SWM Standards and Specifications.

The VDOT RLD will ensure that the information shown on the SWPPP General Information sheets is updated/revised as necessary in order to reflect changes that may occur during the construction phase of the land disturbing (construction) activity. The updated/revised sheets shall be maintained with the designated record set of plans (or other such documents) for the land disturbance (construction) activity.

The SWPPP General Information sheets are to be completed and included in the construction plan set (or other such documents) for land disturbance (construction) activities that disturb an area equal to or greater than 10,000 square feet, or equal to or greater than 2,500 square feet in the area defined as Tidewater, Virginia in the Virginia Chesapeake Bay Preservation Act.

DESIGN FEATURES RELATING TO CONSTRUCTION OR TO REGULATION AND CONTROL OF TRAFFIC MAY BE SUBJECT TO CHANGE AS DEEMED NECESSARY BY THE DEPARTMENT

SECTION VI - PERMANENT BMP INFORMATION Δ

X Denotes information that is to be completed by the RLD.
() See note referenced by number in parentheses.

INSTALLED BMP INFORMATION (VDOT Owned/Operated)

Plan Sheet(s)	Date BMP Made Functional	Type of BMP Installed (See Table A and C)	Geographic Location (County or City)	Latitude/Longitude (1)		VA 6th Order HUC (7)	Receiving Water (2)	Name of Impaired Water (9)	Acres Treated Per BMP (3)			X BMP Maintenance ID Number (10)	BMP Maintenance Manual (11)	BMP Inspection Manual (11)
				LAT	LONG				Impervious	Pervious	TOTAL			
N/A														

ALTERNATIVE BMP INFORMATION

Plan Sheet(s)	Date	Type of BMP Installed (See Table B)	Geographic Location (County or City) (5)	Latitude/Longitude (1) (5)		VA 6th Order HUC (5) (7)	Receiving Water (2)	Name of Impaired Water (9)
				LAT	LONG			
N/A								

Perpetual Nutrient Credits Acquired for Project

Name of Nutrient Credit Generating Entity (6)	Nutrient Credits (lbs./TP./year) Acquired (6) (12)
N/A	

Δ Any changes to the proposed SWM Plan or BMPs necessitated during the construction phase of the project that affects the proposed construction details or potentially affects the information shown in the BMP Tables A and/or B shall be coordinated by the VDOT RLD with the appropriate VDOT District Hydraulics Engineer. The construction plans and the BMP Tables A and/or B are to be formally revised to reflect any authorized/approved changes to the proposed SWM Plan and/or the proposed BMP construction details. All plan revisions shall be completed in accordance with the Road Design Manual and the Construction Division IIM-CD-2013-12.01, signed and sealed in accordance with Department's sealing and signing policy IIM-LD-243 and filed with the construction record drawings maintained in the VDOT Central Office Plan File Room (ProjectWise). Prior to submitting for termination of coverage under the VPDES General Permit For The Discharge Of Stormwater From Construction Activities, the RLD shall have the District Maintenance Division review the BMPs installed with the project (BMP Table A) for acceptance of maintenance responsibility and to obtain a Maintenance ID number for each BMP listed in BMP Table A. The RLD shall use the information in BMP Tables A and B along with the assigned Maintenance ID number and the date that the BMP became functional as a permanent control measure (for BMPs in Table A only) to complete the LD-445D form when certifying the construction of the BMPs and submitting for termination of coverage under the VPDES General Permit For The Discharge Of Stormwater From Construction Activities.

Table A: Permanent BMP Types (1999 Va. SWM Handbook)

- Bio-retention Basin
- Bio-retention Filter
- Constructed Stormwater Wetlands
- Extended Detention Basin
- Extended Detention Basin Enhanced
- Grassed Swale
- Infiltration Basin
- Infiltration Trench
- Manufactured Treatment Device (MTD) (8)
- Retention Basin I
- Retention Basin II
- Retention Basin III
- Sand Filter
- Vegetated Filter Strip
- Other Approved Types (List Type)
- Detention Basin

Table C: Permanent BMP Types (BMP Clearing House)

- Sheet Flow to Vegetated Filter Strip
- Grass Channel
- Soil Compost Amendment
- Permeable Pavement (Level 1)
- Permeable Pavement (Level 2)
- Infiltration Practice (Level 1)
- Infiltration Practice (Level 2)
- Bioretention (Level 1)
- Bioretention (Level 2)
- Dry Swale (Level 1)
- Dry Swale (Level 2)
- Wet Swale (Level 1)
- Wet Swale (Level 2)
- Filtering Practice (Level 1)
- Filtering Practice (Level 2)
- Constructed Wetlands (Level 1)
- Constructed Wetlands (Level 2)
- Extended Detention Pond (Level 1)
- Extended Detention Pond (Level 2)
- Wet Pond (Level 1)
- Wet Pond (Level 2)
- Manufactured Treatment Device (MTD) (8)
- Other Approved Types (List Type)

NOTES:

- (1) In decimal degrees to the nearest one ten-thousandth of a degree.
- (2) For streams with no names, list "(Unnamed Tributary to downstream name)".
- (3) Show acres treated to the nearest one hundredths acre.
- (4) Include agreements with off-site BMP owners.
- (5) Information pertains to the alternative BMP option location, where applicable. Exception - Not required for nutrient credit purchase option.
- (6) Applies to the purchase of nutrient credits only.
- (7) Virginia 6th Order HUC (VAHU6) Example - Y030.
- (8) Final approved shop drawings of Manufactured Treatment Devices (MTDs) are to be included with the BMP information submitted with the LD-445D form.
- (9) List the name of any impaired water to which the BMP discharges. The determination of impaired water shall be based on those streams listed as impaired in the DEQ 2012 305(b)/303(d) Water Quality Assessment Integrated Report and shall be the first named waterbody to which the BMP discharges. The impaired waters are those impaired by sediment, total suspended solids, turbidity, nitrogen or phosphorus.
- (10) BMP Maintenance ID Number is to be assigned by the District Maintenance Division at permit termination or project completion. This ID number shall be assigned prior to the permit close out process and entered by the area construction engineer under this column, per IIM-LD-95

- (11) Provide the section of each Maintenance manual that pertains to the type of BMP. Both manuals can be found at www.vdot.virginia.gov/business/manuals in the Maintenance selections. Example: Section 4 would be noted for both the maintenance and inspection manuals for a Bioretention Infiltration BMP.
- (12) Nutrient credits purchased to the nearest one hundredth pound.

Revised 5/1/19

PROJECT 0311-080-913	SHEET NO. 5D
-------------------------	-----------------

PROJECT MANAGER LEONARD GISNER, 540-387-5457, VDOT SALEM DISTRICT
SURVEYED BY, DATE S.L. HOLLANDSWORTH, 11-15-18, 540-387-5227, VDOT SALEM DISTRICT
DESIGN BY TRANSYSTEMS CORPORATION, (678) 244-9730
SUBSURFACE UTILITY BY, DATE N/A

TRAIL DESIGN

COMMONWEALTH OF VIRGINIA
ALEXANDER STONE
Lic. No. 0402061165
PROFESSIONAL ENGINEER

TranSystems
Richmond, Virginia
ROADWAY ENGINEER

REVISED	STATE	ROUTE	STATE PROJECT	SHEET NO.
	VA.	311	0311-080-913 R201.B618	3

DESIGN FEATURES RELATING TO CONSTRUCTION OR TO REGULATION AND CONTROL OF TRAFFIC MAY BE SUBJECT TO CHANGE AS DEEMED NECESSARY BY THE DEPARTMENT

NOTE: CONTROLLING AGENCY FOR ALL UNITED STATES OF AMERICA PARCELS SHALL BE THE NATIONAL PARK SERVICE.

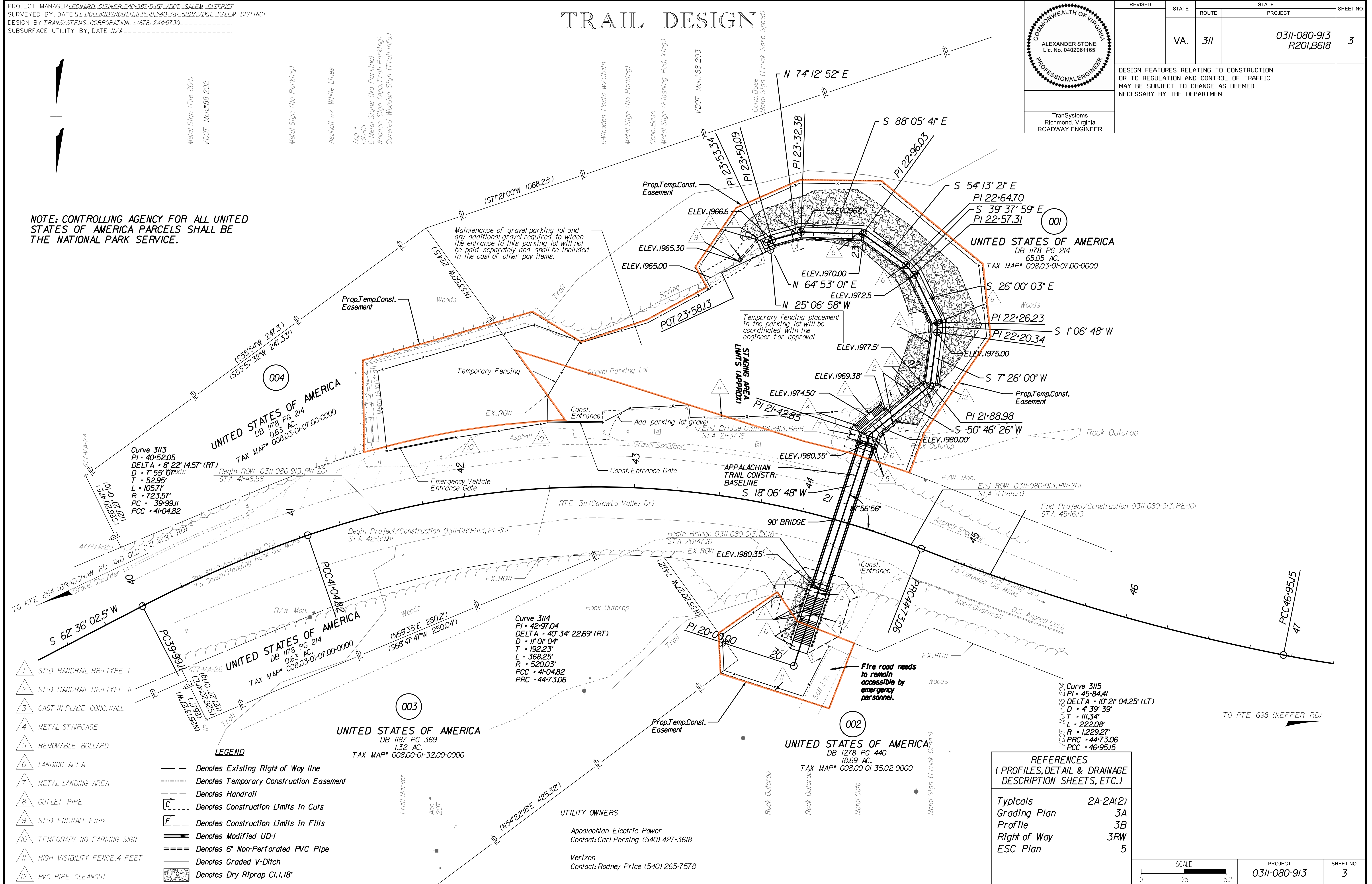

- 1 ST'D HANDRAIL HR-I TYPE I
- 2 ST'D HANDRAIL HR-I TYPE II
- 3 CAST-IN-PLACE CONC. WALL
- 4 METAL STAIRCASE
- 5 REMOVABLE BOLLARD
- 6 LANDING AREA
- 7 METAL LANDING AREA
- 8 OUTLET PIPE
- 9 ST'D ENDWALL EW-I2
- 10 TEMPORARY NO PARKING SIGN
- 11 HIGH VISIBILITY FENCE, 4 FEET
- 12 PVC PIPE CLEANOUT

LEGEND

- Denotes Existing Right of Way line
- - - - - Denotes Temporary Construction Easement
- Denotes Handrail
- [C] --- Denotes Construction Limits in Cuts
- [F] --- Denotes Construction Limits in Fills
- ==== Denotes Modified UD-I
- ==== Denotes 6" Non-Perforated PVC Pipe
- Denotes Graded V-Ditch
- [Pattern] Denotes Dry Riprap Cl. 1, 18"

REFERENCES
(PROFILES, DETAIL & DRAINAGE DESCRIPTION SHEETS, ETC.)

Typicals	2A-2A(2)
Grading Plan	3A
Profile	3B
Right of Way	3RW
ESC Plan	5

SCALE	PROJECT	SHEET NO.
0 25 50'	0311-080-913	3

PROJECT MANAGER: Wendy Hwang, (540) 387-5470, JNDOT
 SURVEYED BY: S.L. Hollandsworth, L.S., (540) 387-5227
 DESIGN BY: E.L. DESIGN CORPORATION, (703) 359-5261
 SUBSURFACE UTILITY BY: S.L. Hollandsworth, L.S., (540) 387-5227

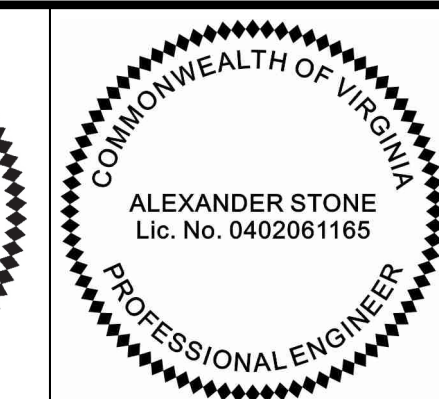
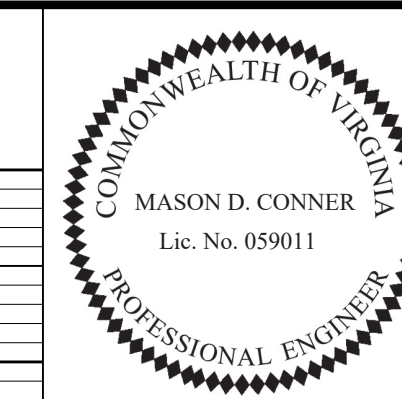

REVISED	STATE	ROUTE	STATE	PROJECT	SHEET NO.
	VA.	311		0311-080-913 R201, B618	3B

DESIGN FEATURES RELATING TO CONSTRUCTION OR TO REGULATION AND CONTROL OF TRAFFIC MAY BE SUBJECT TO CHANGE AS DEEMED NECESSARY BY THE DEPARTMENT

TranSystems
Richmond, Virginia
Hydraulic Engineer

TranSystems
Richmond, Virginia
Roadway Engineer

PEDESTRIAN BRIDGE PROFILE

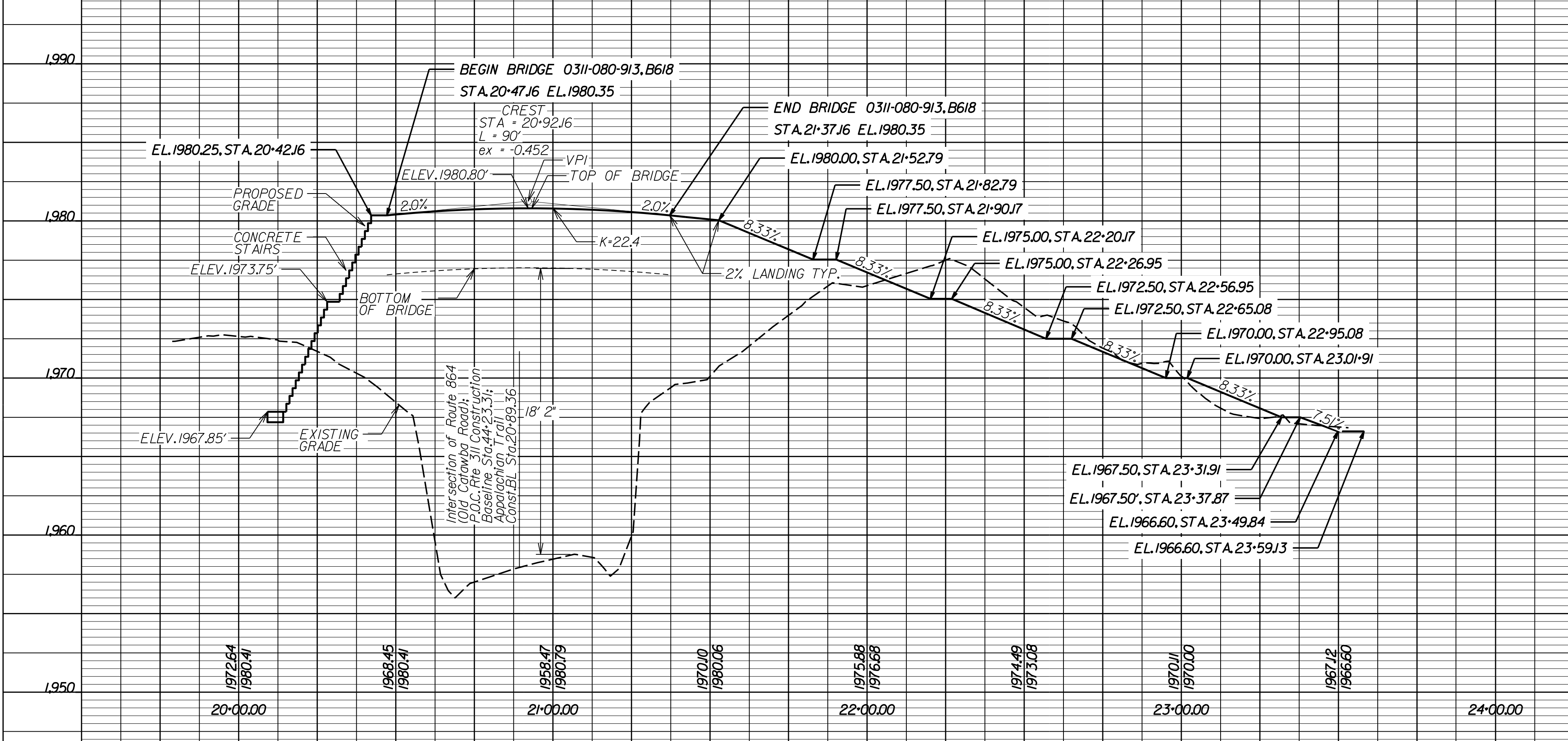

ROUTE 311 PROFILE

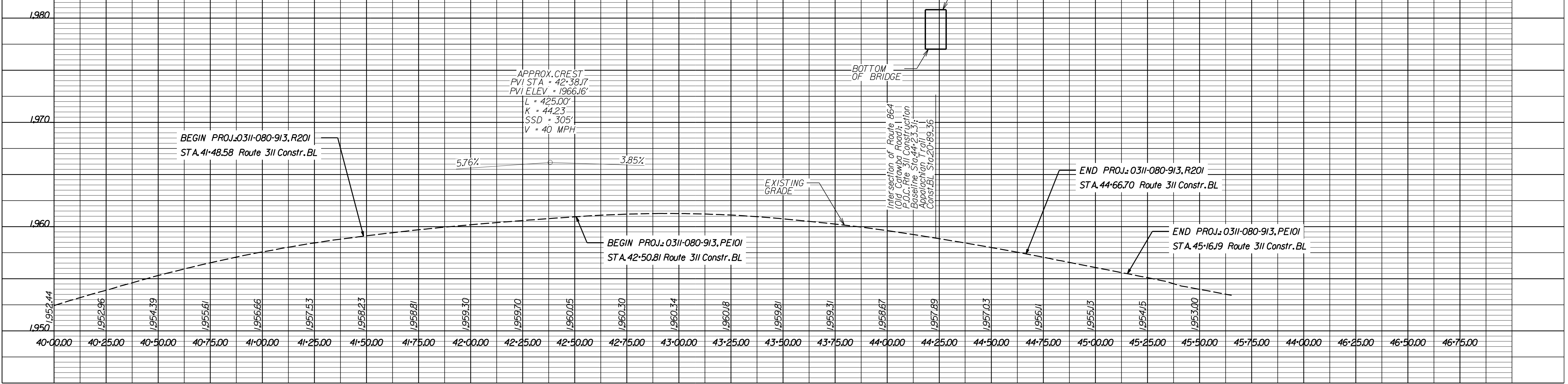

Scale 1" = 25' Horizontal
1" = 10' Vertical

PROJECT
0311-080-913

SHEET NO.
3B

PROJECT MANAGER LEONARD GISNER, 540-387-5457, VDOT SALEM DISTRICT
SURVEYED BY, DATE S.L. HOLLANDSWORTH, 11-15-18, 540-387-5227, VDOT SALEM DISTRICT
DESIGN BY TRANSYSTEMS CORPORATION, (678) 244-9730
SUBSURFACE UTILITY BY, DATE N/A

RIGHT OF WAY

REVISED	STATE	ROUTE	STATE PROJECT	SHEET NO.
	VA	311	0311-080-913 R201.B618	3RW
DESIGN FEATURES RELATING TO CONSTRUCTION OR TO REGULATION AND CONTROL OF TRAFFIC MAY BE SUBJECT TO CHANGE AS DEEMED NECESSARY BY THE DEPARTMENT				
VDOT Location & Design Salem, Virginia Land Surveyor				

NOTES:

- THIS RIGHT OF WAY PLAN SHEET REPRESENTS A SURVEY SHOWING PROPOSED RIGHT OF WAY, PERMANENT EASEMENTS, TEMPORARY EASEMENTS & PRESCRIPTIVE EASEMENTS.
- EXISTING PROPERTY LINES SHOWN HEREON ARE BASED ON A COMPILATION SURVEY. SAID PROPERTY LINES ARE COMPILED FROM VARIOUS SOURCES, FOUND FIELD MONUMENTATION, METES AND BOUNDS DESCRIPTIONS AND RECORDED PLATS. SAID PROPERTY LINES ARE A BEST FIT BASED ON COMPILED DATA AND DO NOT REPRESENT A BOUNDARY SURVEY.
- PHYSICAL IMPROVEMENTS ARE NOT SHOWN HEREON.
- THIS RIGHT OF WAY PLAN SHEET WAS PREPARED WITHOUT THE BENEFIT OF A TITLE REPORT AND MAY NOT SHOW ALL EASEMENTS WHICH MAY AFFECT THE PROPERTY SHOWN HEREON.
- NO DESIGNATION OR LOCATION OF SUBSURFACE UTILITIES WAS PERFORMED DURING PREPARATION OF THIS RIGHT OF WAY PLAN SHEET.
- THIS SURVEY DATUM IS BASED ON VDOT PROJECT 0311-080-913.
- ALL MONUMENTATION TO BE SET AT PROPOSED RIGHT OF WAY BREAKS UPON COMPLETION OF CONSTRUCTION.
- NO CEMETERY SITES WERE OBSERVED ON THE SUBJECT PROPERTY. THIS DOES NOT PRECLUDE THEIR EXISTENCE.
- BEARING AND DISTANCES SHOWN IN PARENTHESIS ARE BASED ON RECORDED DEEDS AND PLAT DATA.
- ALL AREAS SHOWN FOR RIGHT OF WAY AND EASEMENT TAKES ARE APPROXIMATE ONLY.

LEGEND

- 0.00 Existing R/W Figures and lines denote Existing Right of Way
- 0.00 PROP. TEMP. EASEMENT Figures in parenthesis and dot-dot-dashed lines denote Temporary Easements
- (N-0000000.000, E-0000000.000) VDOT Project Coordinates
- (N-3000000.000, E-1000000.000) VA State Plane, South Zone Coordinates
- SPC VA South Combined Factor = 0.999856883
- RM-2 3/8" Iron Rod With Cap
- PROP. Proposed
- PERM. Permanent
- CONSTR. Construction
- ESMT. Easement
- TEMP. Temporary
- DRAIN. Drainage
- SOFT Square Feet

Curve	Delta Angle	Radius	Arc Length	Chord Length	Chord Bearing
C1	07°08'45"	517.35'	64.52'	64.48'	S73°24'03"E
C2	13°16'54"	517.41'	119.94'	119.67'	N80°42'26"E

Line	Bearing	Length
L1	S02°55'40"E	23.47'
L2	S35°50'29"E	19.50'
L3	S53°13'44"W	12.76'
L4	S35°50'29"E	19.64'
L5	S30°00'25"E	13.53'

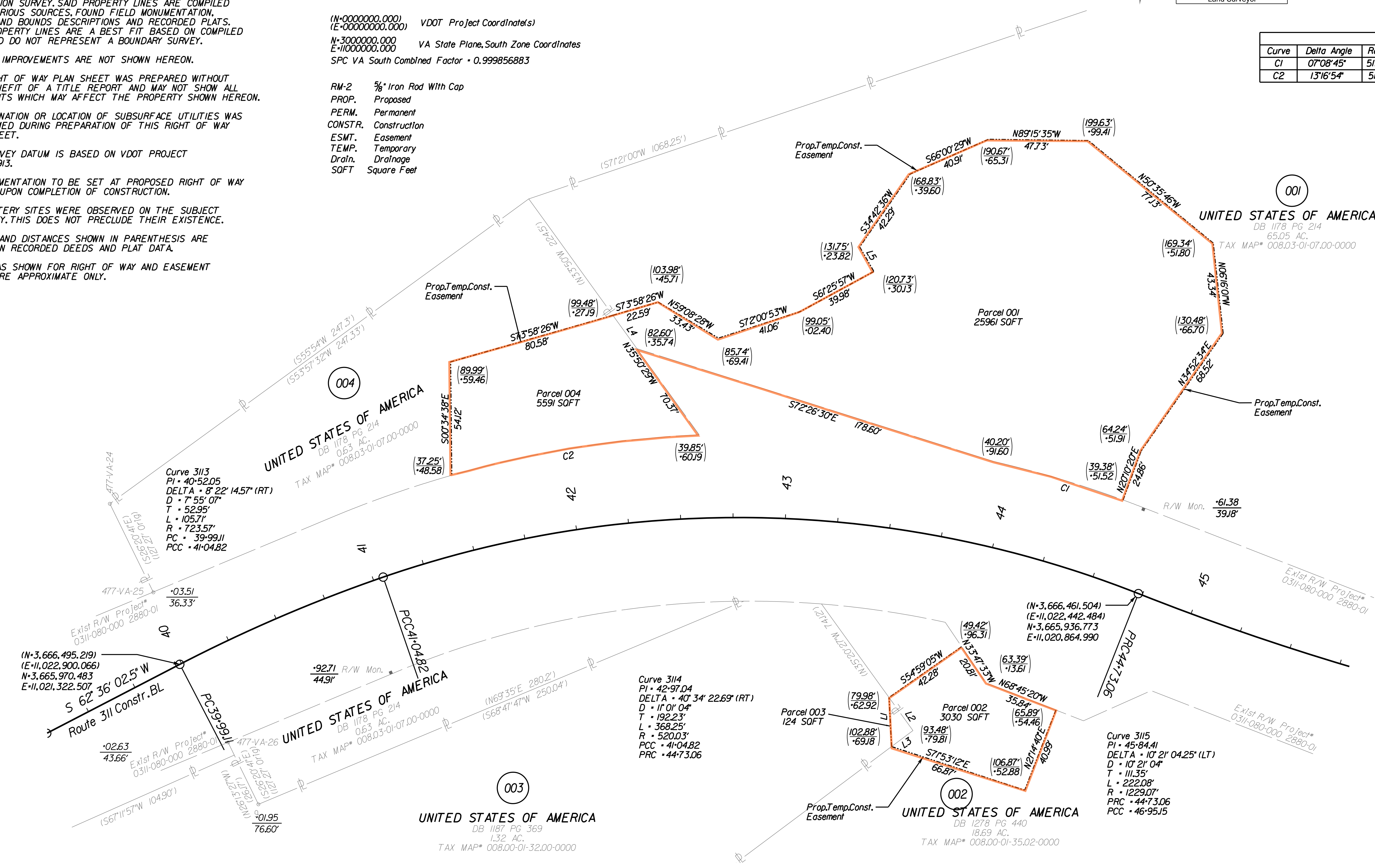

Parcel	Proposed Temporary Construction Easements
001	25,961 SOFT
002	3,030 SOFT
003	124 SOFT
004	5,591 SOFT

Exhibit C

ANST Plan for Inadvertent Discoveries

Exhibit C

Appalachian National Scenic Trail Plan for Inadvertent Discoveries

The following plan outlines procedures to follow if archaeological materials or human remains are discovered while working on NPS lands.

What are cultural resources?

A cultural resource discovery could be prehistoric or historic. Examples include:

- An accumulation of shell, burned rocks, or other food related materials
- Bones or small pieces of bone,
- An area of charcoal or very dark stained soil with artifacts,
- Stone tools or waste flakes (i.e. an arrowhead, or stone chips),
- Clusters of glass, pottery, tin cans or bottles, logging or agricultural equipment
- Buried railroad tracks, decking, or other industrial materials
- Building foundations

When in doubt, assume the material is a cultural resource.

What do you do if you uncover a Cultural Resource?

Step 1: Stop work. If any employee, contractor or subcontractor believes that he or she has uncovered a cultural resource at any point in the project, all work adjacent to the discovery must stop. The discovery location should be secured at all times.

The area of work stoppage will be adequate to provide for the security, protection, and integrity of the cultural resource. The contractor or project leader will be responsible for taking appropriate steps to protect the discovery. At a minimum, the immediate area will be secured to a distance of fifty (50) feet from the discovery. Vehicles, equipment, and unauthorized personnel will not be permitted to traverse the discovery site.

All artifacts are property of the USA and should not be collected. Leave all cultural resources in place unless directed otherwise.

Step 2: Notify Park Staff. Immediately contact the Appalachian National Scenic Trail Superintendent at (304-535-6279), and Archaeologist Joel Dukes (office 978-970-5143; cell 617-429-4468). If they cannot be reached, contact Jim Von Haden, Integrated Resource Manager, at 304-535-4009. Then contact Park Law Enforcement Dispatch at 1-866-677-6677.

If the inadvertent discovery is made during projects without an Archaeological Monitor on site, notify the Park Staff listed above. They will then notify the Northeast Region Archaeology Program (NRAP) for guidance.

If the inadvertent discovery is made during a project with an Archaeological Monitor on site, the Monitor will notify Park Staff and NRAP. The monitor should then begin the documentation process so that consultation can begin.

Step 3: Follow Park Guidance. Park Staff will visit the site as soon as possible to evaluate the site and consult with NRAP to determine if work can resume or if the project must be halted until further notice. If an NPS approved Archeological Monitor is on site, they must be notified of any discoveries and can determine if a work stoppage is required and any other appropriate actions to take.

If human remains are found, all work in the area shall stop. Park Law Enforcement shall be notified to begin the determination if the remains are from a crime scene or are archaeological in nature. If archaeological in nature Park Staff shall notify the State Archaeologist and NRAP immediately so that consultation can begin.

Exhibit D

Fire Road Closure



closure

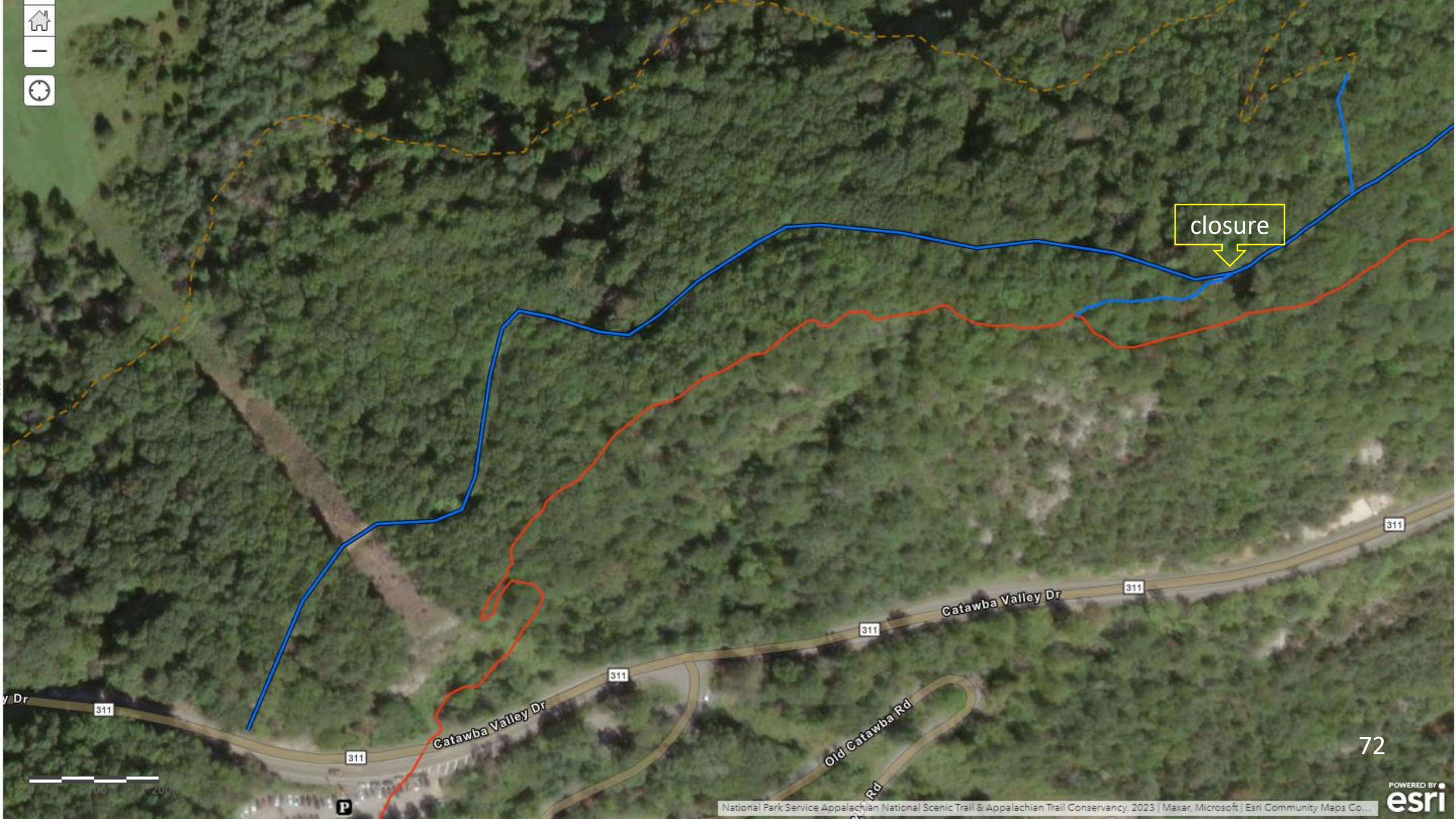



I-495 SOUTHSIDE EXPRESS LANES STUDY

ENVIRONMENTAL ASSESSMENT OVERVIEW

| Chris Swanson

June 20, 2023

Northern Virginia Regional Express Lanes Network

- 90+ mile Express Lanes network planned in Northern Virginia
- 84 miles in service
 - I-95, I-395, I-495, I-66 Inside the Beltway, I-66 Outside the Beltway
- 13 miles under construction
 - I-95 to Fredericksburg (10 miles to be in service August 2023)
 - I-495 Northern Extension (2.5 miles to be in service late 2025)
 - I-95 Express Lanes/Opitz Boulevard Ramp (to be in service Fall 2024)
- Under study
 - I-495 Southside Express Lanes
 - I-95 Bi-Directional Study
- Three independent operators



Study Area

- 11 miles of the southern section of I-95/I-495 (Capital Beltway)
- Springfield interchange (I-95/I-395/I-495) in Fairfax County, VA to the MD 210 interchange in Prince George's County, MD
- The study area is the last section of I-495 in Virginia where Express Lanes have not been implemented



Study Process and Schedule

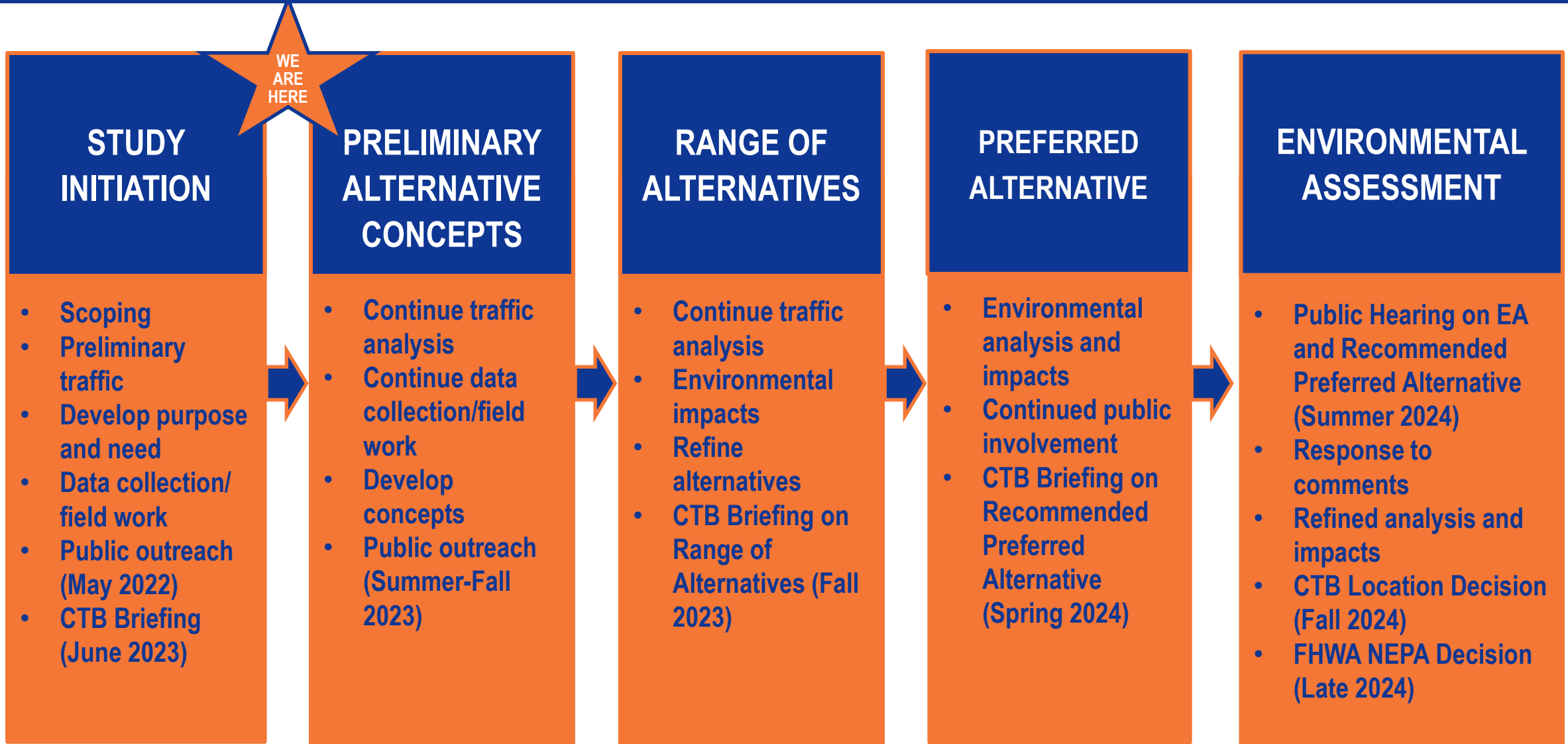

Agency & Public Comment

- Agencies and the public were presented with opportunity to inform the Purpose and Need
 - Scoping
 - May 2022 Public Information Meetings (PIMs)
- Presentation and discussion at monthly NEPA agency meetings (February 2022 – October 2022)
- Obtained concurrence on Purpose & Need
- Continue monthly NEPA agency meetings
- Anticipate concurrence on Range of Alternatives in Fall 2023

Weekday Daily Traffic Volumes

2022 and 2050 No Build



Existing 2022 Congestion Heat Map

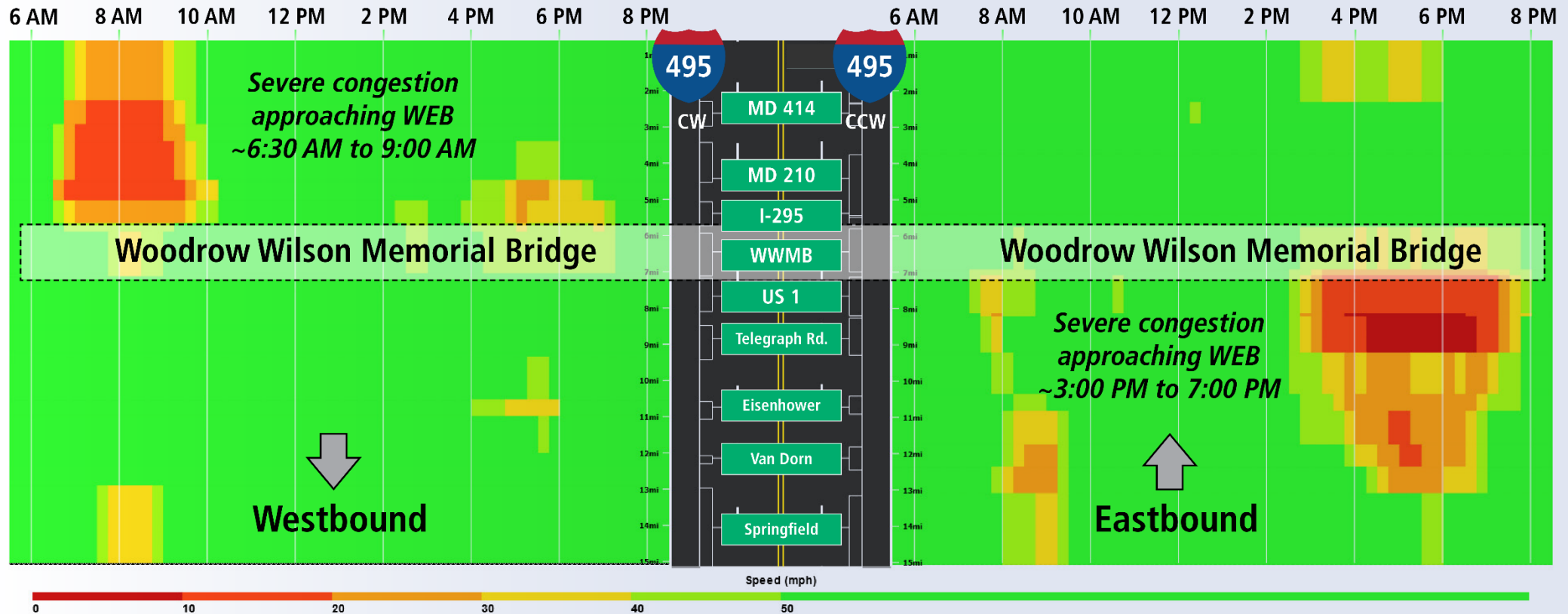

Existing Typical Sections

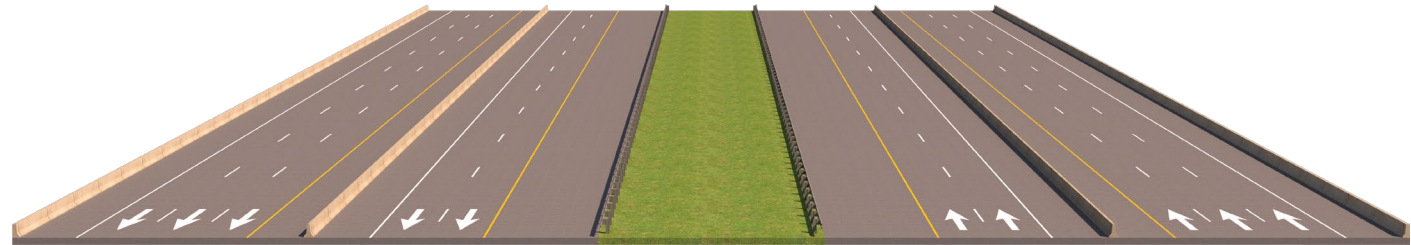
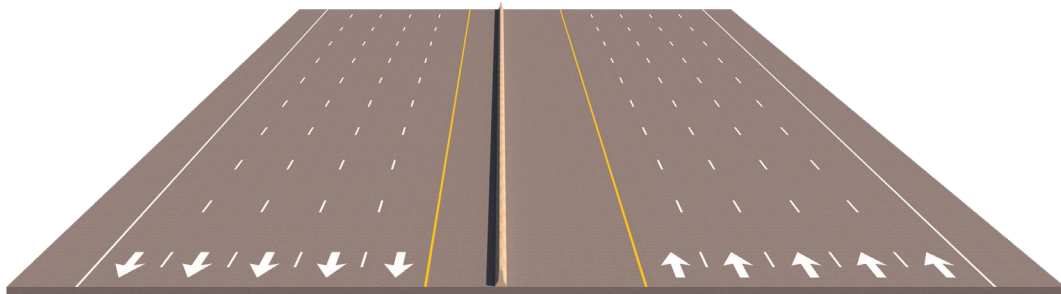
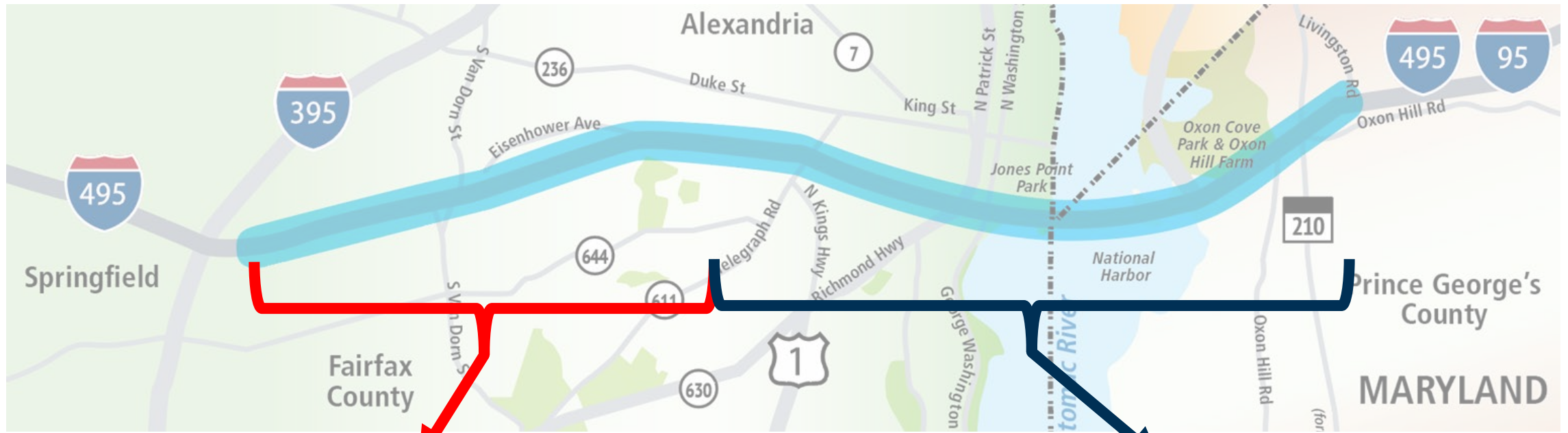

Existing Woodrow Wilson Memorial Bridge

- Project would not widen existing bridge
- Not feasible to relocate concrete barrier between inner and outer spans
 - Moveable bridge
 - Fire standpipe
- Will not preclude space for rail in the future (Blue line)



Purpose & Need

The purpose of the I-495 SEL Study is to evaluate transportation improvements that would extend and provide continuity of the Express Lanes system on the I-95 / I-495 Capital Beltway from the I-95 / I-395 / I-495 Springfield Interchange in Fairfax County, VA to the I-495 / MD 210 Interchange in Prince George's County, MD

The following needs have been identified for this Study:

- Provide Express Lanes system continuity
- Provide additional travel choices
- Reduce congestion and improve travel reliability
- Improve safety
- Provide consistency with local and regional plans

Next Steps

Activity	Timeframe
Public Involvement Meetings	Fall 2023
CTB Briefing: Range of Alternatives	Fall – Winter 2023
CTB Briefing: Recommend Preferred Alternative	Spring 2024
Public Hearing	Summer 2024
CTB Location Decision on Preferred Alternative	Fall 2024
FHWA NEPA Decision	Late 2024



Virginia Department of Transportation

REVENUE SHARING AND TRANSPORTATION ALTERNATIVES POLICY INITIATIVES

| Russ Dudley, Local Assistance Division

June 20, 2023

Revenue Sharing / Transportation Alternatives Policy Initiatives – Background

2013 - Transportation Alternatives Policy Update

2018 - Revenue Sharing Policy Update: requires 5-year review to Board

2023 - CTB Subcommittee Appointed to Review Policy Initiatives

Program Funding

- Revenue Sharing (\$200M biennial – State Funding)
 - ✓ Funds available in SYIP Years 3 and 4
- Transportation Alternatives (\$55M biennial – Federal Funding)
 - ✓ Funds available in SYIP Years 1 and 2

Overview of 2018 Revenue Sharing Policy Changes

- Reduced Annual Maximum Request (\$10M to \$5M)
- Established a Maximum Allocation per Project (\$10M)
- Further limited Opportunities to transfer Surplus Project Allocations within Locality
- Surplus allocations from cancelled projects cannot be transferred

Results of 2018 Policy Changes

- Transfers of surplus allocations from completed projects went down, but the value of those transfers went up
- Deallocations Value from Completed projects went up 4X
- Deallocations Value from Cancelled projects went up 4X
- Transfers of all allocations from on-going projects were cut in half by Value

Evaluation of Policy Changes found that in spite of success of 2018 Revenue Sharing changes, we still have opportunities to improve efficiency and effectiveness of program allocations & project execution.

2023 Revenue Sharing / Transportation Alternatives Policy Initiatives

Secretary of Transportation Established a CTB Subcommittee to Study Recommendations including Transportation Alternatives:

- Four Subcommittee Meetings
 - Members: Greg Yates (Chair), Hynes, Stant, and Laird, with additional CTB Member participation
 - March – May 2023
- District Staff Feedback Meeting
- Local Stakeholder Webinar with verbal feedback
- Local Stakeholder Survey

2023 Locality Survey

42 Respondents

90% prefer the biennial process

62% support taking surplus project allocations and redistributing based on statewide prioritization process

65% support fully funding Transportation Alternatives Project Requests

90% support current SYIP Allocation Policy Transfer Process allowing transfers below certain thresholds to be administratively completed with those above thresholds approved by Board.

Opportunities for Improvement Identified

- 1. Surplus allocations sit idle for extended periods of time**
- 2. Initiation of new projects is often delayed**
- 3. Need for statewide distribution of available allocations from surpluses**
- 4. Need to improve quality of applications**

REVENUE SHARING POLICY RECOMMENDATIONS

	Issues Identified/Opportunities for Improvement	Proposed Policy	Anticipated Outcomes
1	Current Application process policy is not reflective of the biennial practice	Align policy for application cycle with existing biennial application intake process	Aligns policy with current practice
2	<p>Surplus funding not available to projects with highest needs for funding</p> <p>Surplus funding not distributed in a timely manner</p> <p>Current process is not consistent with other funding programs</p> <p>Current practice of project transfers within a locality is not reflective of the project-specific nature of allocations</p>	<p>Surplus funds from completed or canceled projects return to statewide balance entry for redistribution based on standardized prioritization/tiered process. Retain \$5M in statewide balance entry to account for unanticipated needs - replenish as necessary during application cycles.</p> <p>Tier 1 – Localities with a deficit at Construction award Tier 2 – Projects that exhibit a deficit at advertisement Tier 3 – Projects with a deficit during Construction Tier 4 – Projects with a deficit after Construction completion</p> <p>Eliminate all individual transfer requests within localities. Any redistribution or increased allocation to projects will be addressed on a statewide basis using a uniformed reallocation process.</p>	<p>Allows available funding to immediately support projects that have a deficit</p> <p>Minimizes idle allocations while reducing impacts of inflation / other project delivery cost increases</p> <p>Redistribution of available funds using a tiered process to reflect the urgency and time sensitive need for funds on existing projects.</p> <p>Aligns with premise that allocations are made to projects through application process rather than generally to localities</p>
3	Deallocated funds are not available in a timely manner due to single annual deallocation action	Deallocate funds monthly	<p>CTB will be informed of deallocations as part of monthly transfer actions</p> <p>Allows available funding to immediately support projects in deficit</p> <p>Minimizes idle allocations which reduces impacts of inflation / other project delivery cost increases</p>
4	Project initiations are being delayed waiting on execution of project administration agreements	Require that project administration agreements be executed within six months of agreement transmittal to locality or risk deallocation	<p>Encourages expeditious start to projects</p> <p>Minimizes delays of expenditures</p>

TRANSPORTATION ALTERNATIVES POLICY RECOMMENDATIONS

	Issues Identified/Opportunities for Improvement	Proposed Policy	Anticipated Outcomes
1	Current Application process policy is not reflective of the biennial practice	Align policy for application cycle with existing biennial application intake process	Aligns policy with current practice
2	Surplus funding not available to projects with highest needs for funding Surplus funding not distributed in a timely manner Current process is not consistent with other funding programs Current practice of project transfers within a locality is not reflective of the project-specific nature of allocations	Surplus funds from completed or canceled projects return to statewide balance entry for redistribution based on standardized prioritization/tiered process. Retain \$2M in statewide balance entry to account for unanticipated needs - replenish as necessary during application cycles. Tier 1 – Localities with a deficit at Construction award Tier 2 – Projects that exhibit a deficit at advertisement Tier 3 – Projects with a deficit during Construction Tier 4 – Projects with a deficit after Construction completion Projects selected by CTB but cancelled within the first year of allocation may have allocations re-assigned to another project from that year's application pool. Eliminate all individual transfer requests within localities. Any redistribution or increased allocation to projects will be addressed on a statewide basis using a uniformed reallocation process.	Allows available funding to immediately support projects in deficit. Minimizes idle allocations while reducing impacts of inflation / other project delivery cost increases Redistribution of available funds using a tiered process to reflect the urgency and time sensitive need for funds on existing projects. Aligns with premise that allocations are made to projects through application process rather than generally to localities Ensures appropriate distribution of population-based allocations
3	Projects are delayed when not fully funded due to uncertainty of available funding to complete project Partially funding application requests is inconsistent with other funding programs	Fully fund project application requests, with limited opportunity to request additional funding (see tiering in recommendation #2)	Provides incentive to initiate project promptly with confidence of funding availability Encourages better project planning and estimates Consistency with other funding programs
4	Current process of distributing allocations for CTB Member selections does not account for fluctuations in available funding	Adjust District Member and At-large/Secretary CTB Member allocations so that allocations are equally distributed	Provides equitable distribution of funding for CTB Member allocations
5	Program funding not suitable for large projects Larger projects often do not meet requirement to reach construction phase in four years	Establish a maximum lifetime award amount of \$2.5 million per project	Ensures allocations are available for broader range of applicants Encourages smaller, more focused projects which can be completed quickly Aligns projects' size with intent and scale of the Transportation Alternatives Program
6	Localities submit many project applications that are not viable application or have not been thoroughly vetted internally, resulting in unnecessary effort during application reviews	Establish application caps of 8 Pre-Applications and 5 Full Applications for each jurisdiction	Encourages localities to prioritize and submit ready and suitable projects rather than submitting multiple applications in the hopes of securing an award Allows VDOT to focus review efforts on most viable project applications
7	Project initiations are being delayed waiting on execution of project administration agreements	Require that project administration agreements be executed within six months of agreement transmittal to locality or risk project deallocation	Encourages expeditious start to projects Minimizes delays of expenditures

Next Steps

- July 2023 - Staff to bring Decision Brief and Resolutions to CTB for formal vote
- Following CTB Approval - Revenue Sharing and Transportation Alternatives Guidance Documents reflecting new policies posted on Town Hall for public comment period
- September 2023 - Final Guidance Documents published



Virginia Department of Transportation



NATIONAL ELECTRIC VEHICLE INFRASTRUCTURE PROGRAM UPDATE

| Chris Berg, Director of Transportation Sustainability

June 20, 2023

National Electric Vehicle Infrastructure (NEVI) Program

- Authorized by Infrastructure Investment and Jobs Act (IIJA)
- IIJA and FHWA Guidance establish program requirements
- Strategically deploy EV charging infrastructure and establish an interconnected national charging network to facilitate data collection, access, and reliability
 - Goal of 500,000 chargers nationwide by 2030
 - Support travel, reduce range anxiety, accelerate awareness
- \$100 million in federal formula funding over 5 years for Virginia
 - VDOT is the lead agency, under the direction of the Secretary of Transportation
 - \$36 million (comprised of FY22 and FY23 allocations) for phase 1 solicitation

Virginia's NEVI Deployment Plan Goals

- **Goal #1: Close Charging Gaps**
 - Fully build out 8 existing Alternative Fuel Corridors (AFCs) within 5 years and identify corridors of statewide significance for future build out
- **Goal #2: Maintain Reliability and Connectivity**
 - Establish strict standards for measuring and reporting charging station uptime and maintaining station performance required by federal NEVI standards and requirements
- **Goal #3: Ensure Widespread Access**
 - Support the deployment of charging stations across urban, suburban, rural, and disadvantaged communities

NEVI Charging Stations

- Installation/upgrade of publicly accessible direct current fast chargers (DCFC)
 - Must first build out designated Alternative Fuel Corridors (AFCs)
 - 1 mile from AFC, every 50 miles, 4 ports per station, 150 kW per port
 - May include on-site distributed energy resources
 - 5 years of operations and maintenance funding
- Third parties will acquire, install, own, operate, and maintain
 - Applicant to provide minimum 20% funding match

NEVI Program Timeline

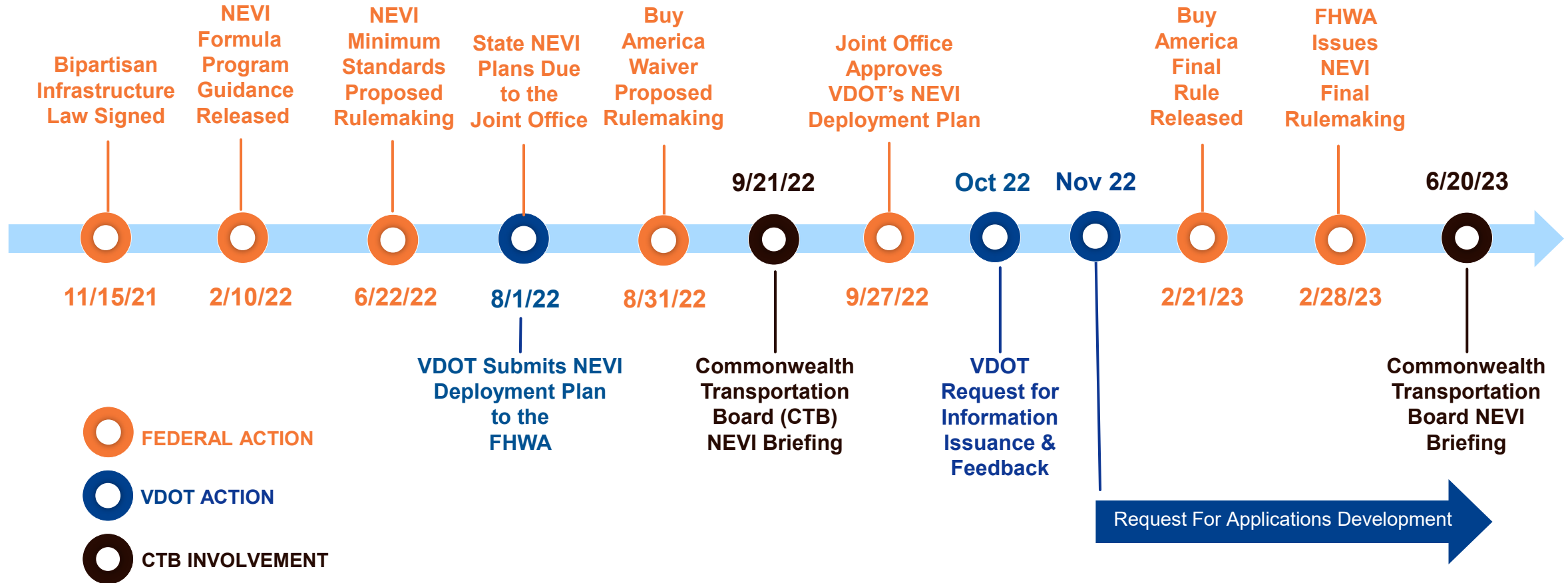

NEVI Program Timeline

- Since the issuance of the Final NEVI Rulemaking on February 28, 2023, VDOT staff have:
 - Incorporated final standards and requirements into Request for Applications (RFA)
 - Engaged the Office of Attorney General in extensive review of the draft RFA
 - Acquired consultant services to advise on the draft RFA and develop a GIS mapping tool to release with the RFA

Alternative Fuel Corridors (AFCs) - Nationally

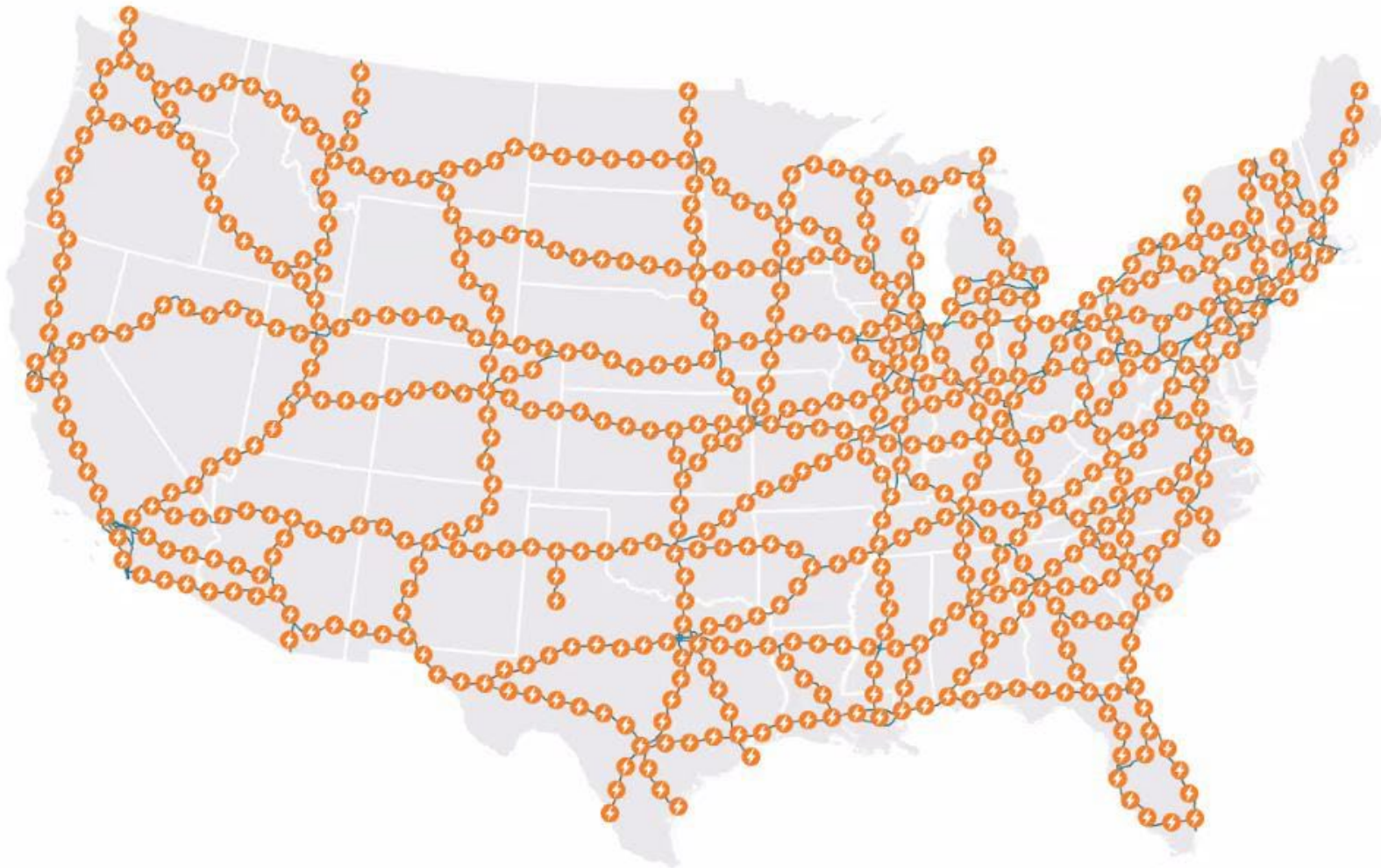

Alternative Fuel Corridors (AFCs) - Virginia

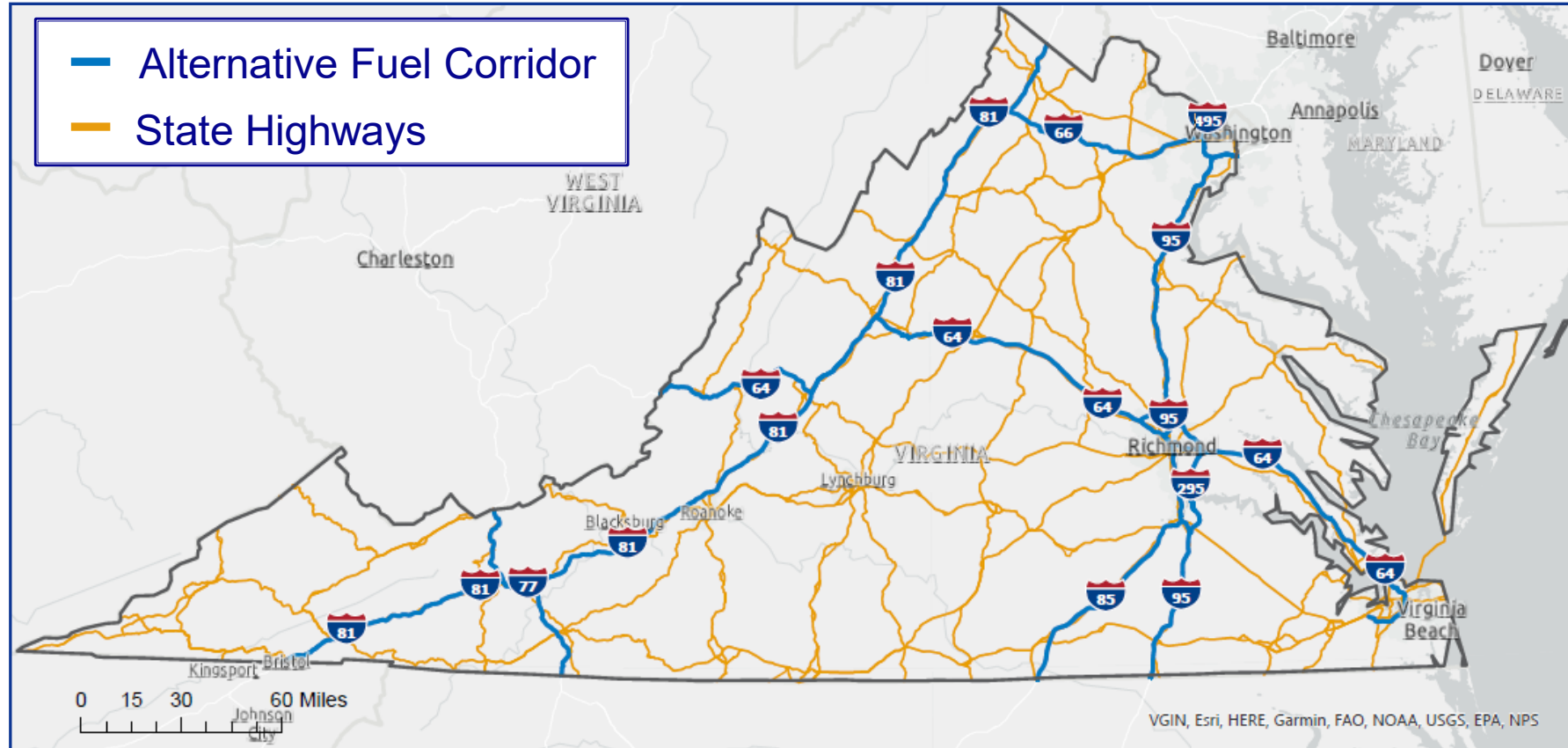

Virginia AFCs:

985 miles that span I-64, I-66, I-77, I-81, I-85, I-95, I-295, and I-495

Request for Applications Proposed Schedule

Activity	Tentative Timeframe
Request for Applications (RFA) Issuance	July 17, 2023
○ Non-Mandatory Pre-application Conference	July 24, 2023
○ Deadline to Submit RFA Clarification Questions	July 31, 2023
○ Clarification Questions and Answers Published	August 14, 2023
Request for Application Deadline	September 11, 2023
VDOT Application Review Completion	November 06, 2023
Tentative Award Notifications	December 11, 2023

Application Eligibility

LEGAL ENTITY

Applicants must be a legal entity in good standing, including an individual, corporation, or other entity registered with the State Corporation Commission, a government entity, or a Tribal Organization

SITE HOST

Able to locate or become a Site Host for publicly-accessible direct-current fast-charging (DCFC) equipment

MINIMUM STANDARDS

Able to comply with:

- Minimum NEVI Formula Program requirements
- Minimum VDOT program requirements

FUNDING MATCH

Able to provide the non-federal funding match of 20% & any additional costs incurred in excess of the maximum award of \$1,000,000 per station

MAINTENANCE

Able to operate and maintain publicly-accessible DCFC equipment for a minimum of five (5) years post-construction

Minimum Standards – Federally Required

- Federal Regulations set minimum standards and requirements for projects funded under the NEVI Formula Program
- Applicants must meet the Minimum Standards in order to be considered
 - Location of EV infrastructure [distance from corridor & between stations]
 - Power and network requirements
 - Procurement process
 - Availability / charging station uptime
 - Payment methods, accessibility, transparency
 - Security [physical & cyber] / data privacy
 - Qualified technicians
 - Data reporting
 - Other federal requirements

Application Evaluation

- Applications will be evaluated based on criteria from federal guidance, program goals, and best practices, which include the following:

- Pricing
- Qualifications
- Site Amenities
- Justice40
- SWaM/DBE
- On-Site Renewable Energy

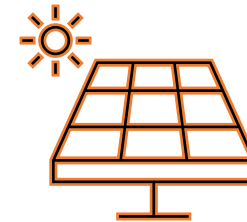
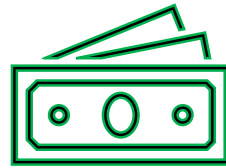

Next Steps...

- Finalize Request for Applications
 - Complete the GIS mapping tool for potential applicants
 - Final Office of Attorney General review
- Release Request For Applications
 - Posting to eVA / Commonwealth's Marketplace
 - Notification to parties interested in submitting an application



FY 2024 – 2029 Commonwealth Transportation Fund (CTF) Six-Year Financial Plan

FY 2024 CTF and VDOT Budgets

Laura Farmer, Chief Financial Officer

June 20, 2023

Commonwealth Transportation Fund (CTF)

Fiscal Years 2024 – 2029 Six-Year Financial Plan

Overview

- ❑ The Six-Year Financial Plan (SYFP) identifies the planned funding for allocation to Highways, Rail, Transit, Ports, Aviation, DMV, and Space Flight
- ❑ The Preliminary Fiscal Years 2024 – 2029 SYFP allocates \$55.4 billion
- ❑ Includes the use of \$988.6 million of Route 58 Corridor Bonds and I-81 Financing
- ❑ Transfers \$5.96 billion to the three regions for transportation improvements and \$913 million in dedicated revenue for WMATA Capital Fund
- ❑ Includes \$570 million of dedicated fuel tax revenue for the I-81 Corridor Improvements
- ❑ Dedicates \$16.2 billion for Maintenance and Operations
- ❑ Provides \$18.2 billion for Construction

Approximately \$4.1 billion of Construction Funding represents Local and Regional Funding for Projects

Commonwealth Transportation Fund (CTF) Revenue Estimate

	FY 2024	FY 2025	FY 2026	FY 2027	FY 2028	FY 2029	TOTAL
Sources of Funds							
Retail Sales and Use Tax	\$ 1,388.2	\$ 1,435.4	\$ 1,472.7	\$ 1,486.0	\$ 1,502.2	\$ 1,541.4	\$ 8,825.9
Motor Vehicle Sales and Use Tax	1,078.2	1,218.2	1,249.6	1,269.4	1,284.9	1,279.6	7,379.9
Motor Fuels Tax	1,499.5	1,561.2	1,611.7	1,657.4	1,701.1	1,744.2	9,775.1
Aviation Fuels Tax	2.0	2.0	2.0	2.0	2.0	2.0	12.0
Road Tax	71.2	72.0	72.7	73.7	73.5	73.2	436.3
International Registration Plan	118.2	119.6	120.0	120.3	120.7	121.0	719.8
Registration Fees	218.4	219.5	221.4	221.0	221.4	221.8	1,323.5
State Insurance Premium Tax	214.5	223.5	235.2	246.4	256.0	256.0	1,431.6
Recordation Tax	52.4	54.5	56.7	59.0	61.3	61.3	345.2
Vehicle Rental Tax	38.9	38.5	38.5	38.5	39.2	39.8	233.4
Highway Use Fee	64.4	66.3	68.3	68.3	68.3	68.3	403.9
Total Commonwealth Transportation Fund	\$ 4,745.9	\$ 5,010.7	\$ 5,148.8	\$ 5,242.0	\$ 5,330.6	\$ 5,408.6	\$ 30,886.6

December 2022 Forecast; Rental Tax excludes share dedicated to WMATA Capital



Commonwealth Transportation Fund Draft Fiscal Years 2024 – 2029

Six-Year Financial Plan Estimated Revenues (in millions)

	FY 2024	FY 2025	FY 2026	FY 2027	FY 2028	FY 2029	FY 2024-2029 Total	Previous FY 2023-2028	Difference
State Transportation Revenues									
Commonwealth Transportation Fund	\$ 4,804.0	\$ 5,010.6	\$ 5,148.7	\$ 5,241.9	\$ 5,330.5	\$ 5,408.5	\$ 30,944.2	\$ 28,318.8	\$ 2,625.4
General Fund	110.0	-	-	-	-	-	110.0	483.2	(373.2)
Prior year funding	-	-	-	-	-	-	-	191.4	(191.4)
Local & Regional Project Participation/Revenue	1,286.8	1,200.0	511.8	825.0	205.9	185.0	4,214.5	3,480.5	734.0
Other Fund Revenue	530.8	427.2	434.1	442.7	446.3	440.7	2,721.7	2,438.9	282.9
Total	6,731.6	6,637.8	6,094.6	6,509.6	5,982.7	6,034.2	37,990.5	34,912.8	3,077.7
Federal Revenues	1,671.9	1,607.8	1,636.1	1,526.6	1,556.1	1,586.1	9,584.5	9,684.4	(99.9)
Total Revenues	8,403.5	8,245.6	7,730.7	8,036.3	7,538.8	7,620.3	47,575.0	44,597.2	2,977.8
Other Financing Sources									
Interstate 81 Financing	237.9	-	272.9	251.4	-	-	762.2	652.8	109.4
GARVEE Bonds	-	-	-	-	-	-	-	19.2	(19.2)
Route 58	-	152.2	74.2	-	-	-	226.4	226.4	-
Total	237.9	152.2	347.1	251.4	-	-	988.6	898.4	90.2
Total Operating Revenues and Other Financing Sources	\$ 8,641.4	\$ 8,397.8	\$ 8,077.8	\$ 8,287.6	\$ 7,538.8	\$ 7,620.3	\$ 48,563.6	\$ 45,495.6	\$ 3,068.0
Revenue Supporting Transfer Payments									
Regional Transportation Funds	1,005.6	951.0	978.1	994.5	1,008.3	1,020.7	5,958.2	5,295.0	663.2
WMATA Capital Fund Revenue	152.3	150.4	151.2	152.0	153.1	154.2	913.3	814.6	98.7
Grand Total	\$ 9,799.3	\$ 9,499.2	\$ 9,207.1	\$ 9,434.1	\$ 8,700.2	\$ 8,795.2	\$ 55,435.1	\$ 51,605.3	\$ 3,829.9

Green indicates change from April



Revenue Updates

VDOT Specific Items

- **Other Fund Revenue**
 - **Deployment of fuel reserve funding remaining from FY 2023 of \$77.4 million; available in FY 2024**
 - **Updated I-66 Inside the Beltway toll facility revenue assumptions**
- **Federal Revenue**
 - **Appalachian Development Highway System (ADHS) Allocation of \$8.3 million**
 - As with recent ADHS funding, funds were programmed to Corridor Q Project with corresponding release of Route 58 Corridor Funding
 - **I-64 Widening Project - Federal Rural Grant Award of \$25 million**
- **Other Financing Sources**
 - **Update of I-81 Financing Model to accommodate increased project costs; incorporates additional TIFIA Financing assumptions for project delivery**

Commonwealth Transportation Fund Preliminary Fiscal Years 2024 – 2029 Six-Year Financial Plan Estimated Allocations (in millions)

	FY 2024	FY 2025	FY 2026	FY 2027	FY 2028	FY 2029	FY 2024-2029 Total	2023-2028 SYFP	Difference
Debt Service	\$ 409.4	\$ 418.0	\$ 431.0	\$ 425.0	\$ 431.3	\$ 442.7	\$ 2,557.3	\$ 2,476.8	\$ 80.5
Other Agencies & Transfers	49.3	50.5	50.6	51.8	52.0	53.3	307.5	303.5	4.0
Maintenance & Operations	2,727.3	2,591.2	2,645.0	2,702.3	2,760.9	2,763.4	16,190.2	15,246.1	944.1
Administration & Other Programs	598.4	603.5	580.1	589.3	601.3	613.4	3,586.0	3,318.9	267.1
Toll Programs	94.0	105.9	107.5	109.1	109.1	97.3	622.9	585.4	37.5
Special Structures	85.0	87.3	89.1	91.0	93.0	95.1	540.6	509.4	31.2
Public Transportation	655.9	645.4	671.0	684.8	676.8	681.3	4,015.3	3,725.4	289.9
Virginia Passenger Rail Authority	163.6	206.9	209.9	211.3	216.7	177.3	1,185.6	1,314.1	(128.5)
DRPT Rail Assistance	15.2	15.7	15.9	16.1	16.4	16.6	95.9	91.9	4.0
DRPT Administration	19.6	20.2	20.8	21.4	22.1	22.7	126.8	146.2	(19.4)
Port Trust Fund	57.7	60.2	61.3	62.4	63.5	64.4	369.5	340.3	29.2
Airport Trust Fund	34.7	36.2	36.9	37.5	38.2	38.7	222.3	206.0	16.3
Commonwealth Space Flight Fund	22.7	23.7	24.1	24.6	25.0	25.4	145.4	135.0	10.4
Department of Motor Vehicles	22.7	23.7	24.1	24.6	25.0	25.4	145.5	142.1	3.4
Construction	3,644.4	3,469.3	3,070.5	3,196.4	2,367.6	2,463.3	18,211.5	16,714.5	1,497.0
Total Operating Programs	\$ 8,600.1	\$ 8,357.8	\$ 8,037.8	\$ 8,247.6	\$ 7,498.8	\$ 7,580.3	\$ 48,322.3	\$ 45,255.6	\$ 3,066.7
Pass Through Programs									
WMATA Capital Fund	172.3	170.4	171.2	172.0	173.1	174.2	1,033.3	934.6	98.7
Central Virginia Transportation Fund	258.3	236.2	242.7	246.1	249.8	253.3	1,486.4	1,221.6	264.8
Northern Virginia Transportation Authority Fund	442.8	425.1	436.1	441.0	446.7	451.0	2,642.7	2,412.0	230.7
Hampton Roads Regional Transit Fund	41.3	37.7	38.2	38.8	39.3	39.5	234.8	245.1	(10.3)
Hampton Roads Transportation Fund	284.5	272.0	281.1	288.6	292.5	296.9	1,715.6	1,546.3	169.3
Subtotal	1,199.2	1,141.4	1,169.3	1,186.5	1,201.4	1,214.9	7,112.8	6,349.6	763.2
Total	\$ 9,799.3	\$ 9,499.2	\$ 9,207.1	\$ 9,434.1	\$ 8,700.2	\$ 8,795.2	\$ 55,435.1	\$ 51,605.2	\$ 3,829.9



Green indicates change from April

Allocation Updates

- **Debt Service – Updated timing of GARVEEs to be issued in future; released federal funding for formula distribution**
- **Maintenance and Operations – Updates to Exempt Permit Revenue Estimate for VDOT and Locality Payments**
- **Toll Programs – Update to FY 2024 expectations for I-66 Inside the Beltway**
- **Construction**
 - **Allocation of federal funding for ADHS to Corridor Q Project and federal grant to I-64 Gap**
 - **Update I-81 Program based on updated cost estimates and financial capacity**
 - **State and Federal funding available for Formula Distribution due to fuel reserve release and GARVEE debt service release**

Commonwealth Transportation Fund FY 2024 Budget

Revenue (in millions)	Total Estimate
Commonwealth Transportation Fund	\$ 4,804.0
Other Revenue to the Highway Maintenance and Operating Fund	124.5
Other Revenue to the Transportation Trust Fund	1,479.8
Federal Fund	1,671.9
Priority Transportation Fund	1.3
Interstate 81 Corridor Improvement Fund & Financing	324.7
Fuel Tax Revenue for Highway Construction District Grant Program	123.8
General Fund	110.0
Bonds	-
Total Operating Revenues	\$ 8,640.1
Pass Through Revenues	
WMATA Capital Fund	152.3
Central Virginia Transportation Fund	258.3
Northern Virginia Transportation Authority Fund	422.8
Hampton Roads Transportation Fund	284.5
Hampton Roads Regional Transit Fund	41.3
Subtotal	\$ 1,159.2
Total	\$ 9,799.3

CTF Revenues total \$9.8 billion, an increase of 2.9 percent from the Second Revised FY 2023 CTF Budget (adopted in October 2022)

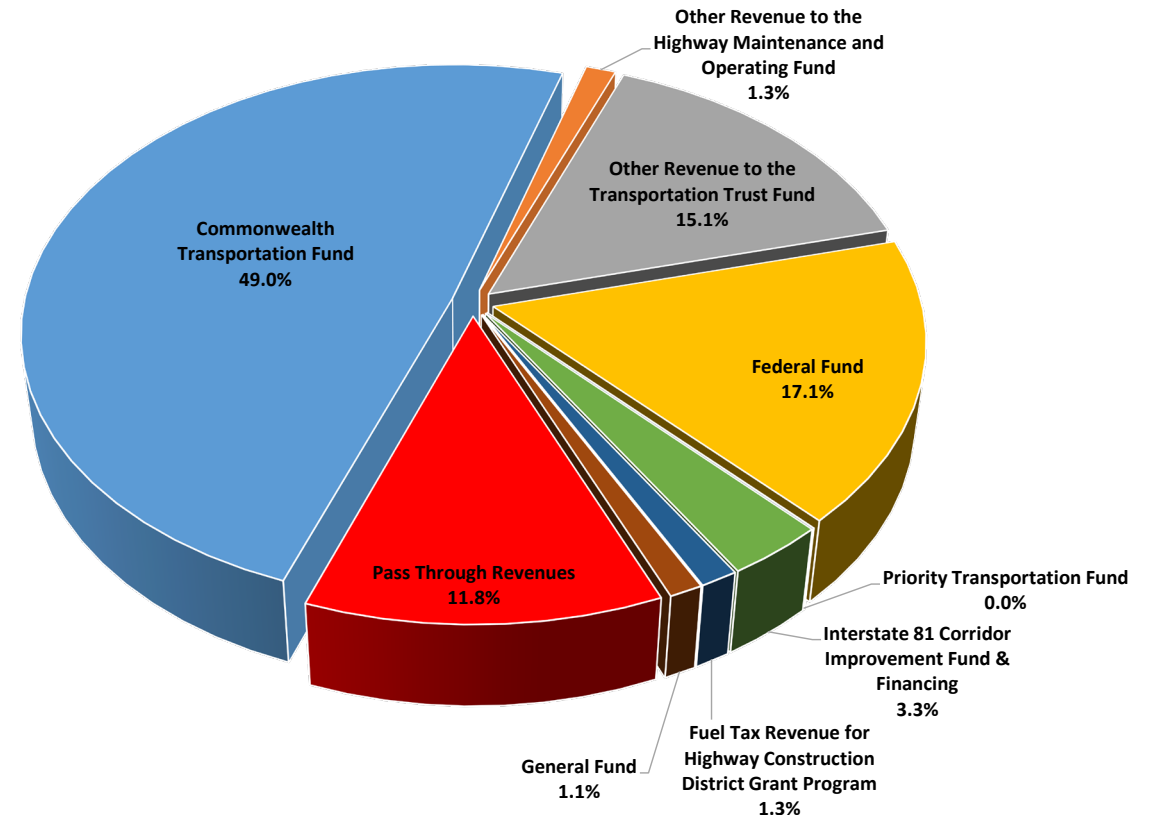

FY 2024 Recommended Allocations

- Highway Maintenance, including VDOT maintained and Locality Maintained, represents 28 percent of budget
- Highway Construction represents 38 percent of the total with support of regional / local funding
- Funding for Rail and Public Transportation is 9 percent of budget

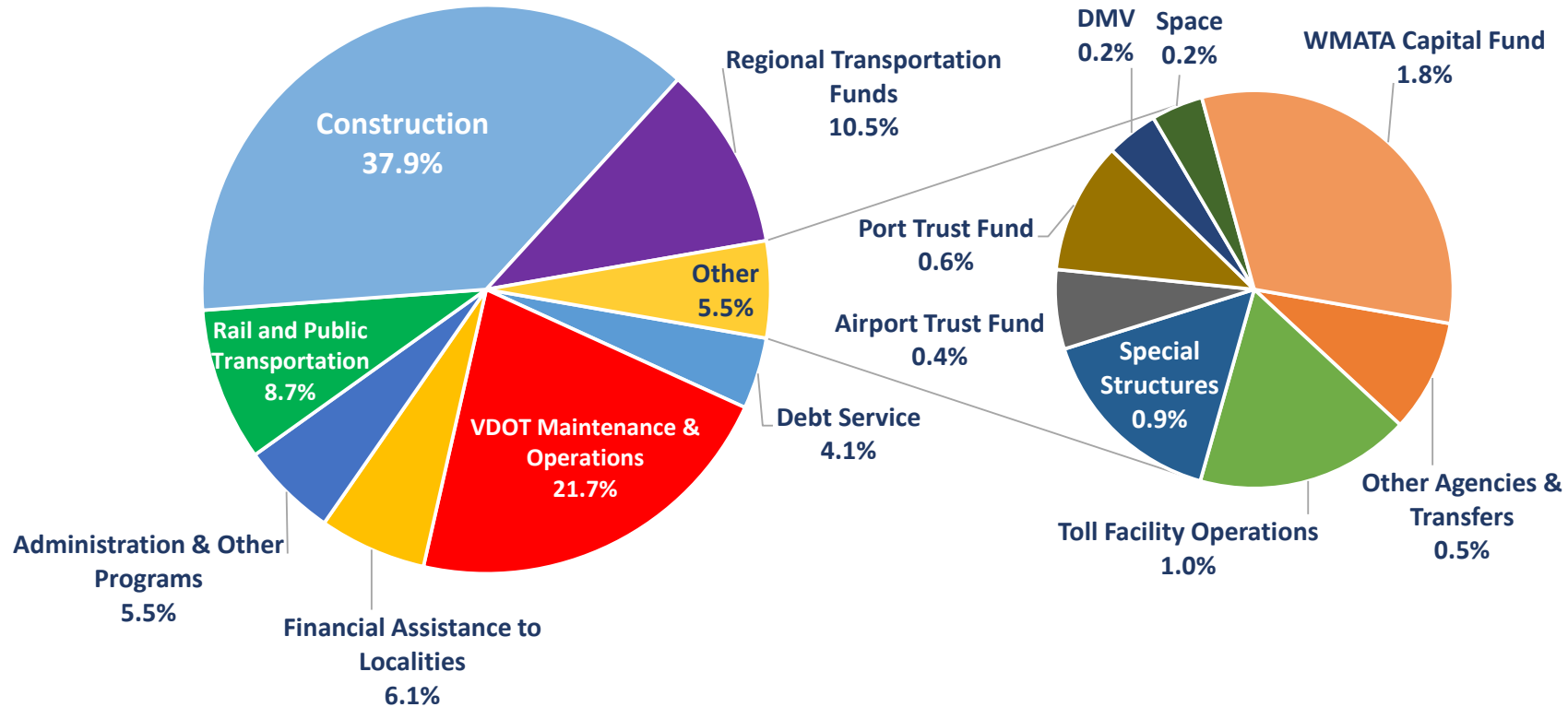

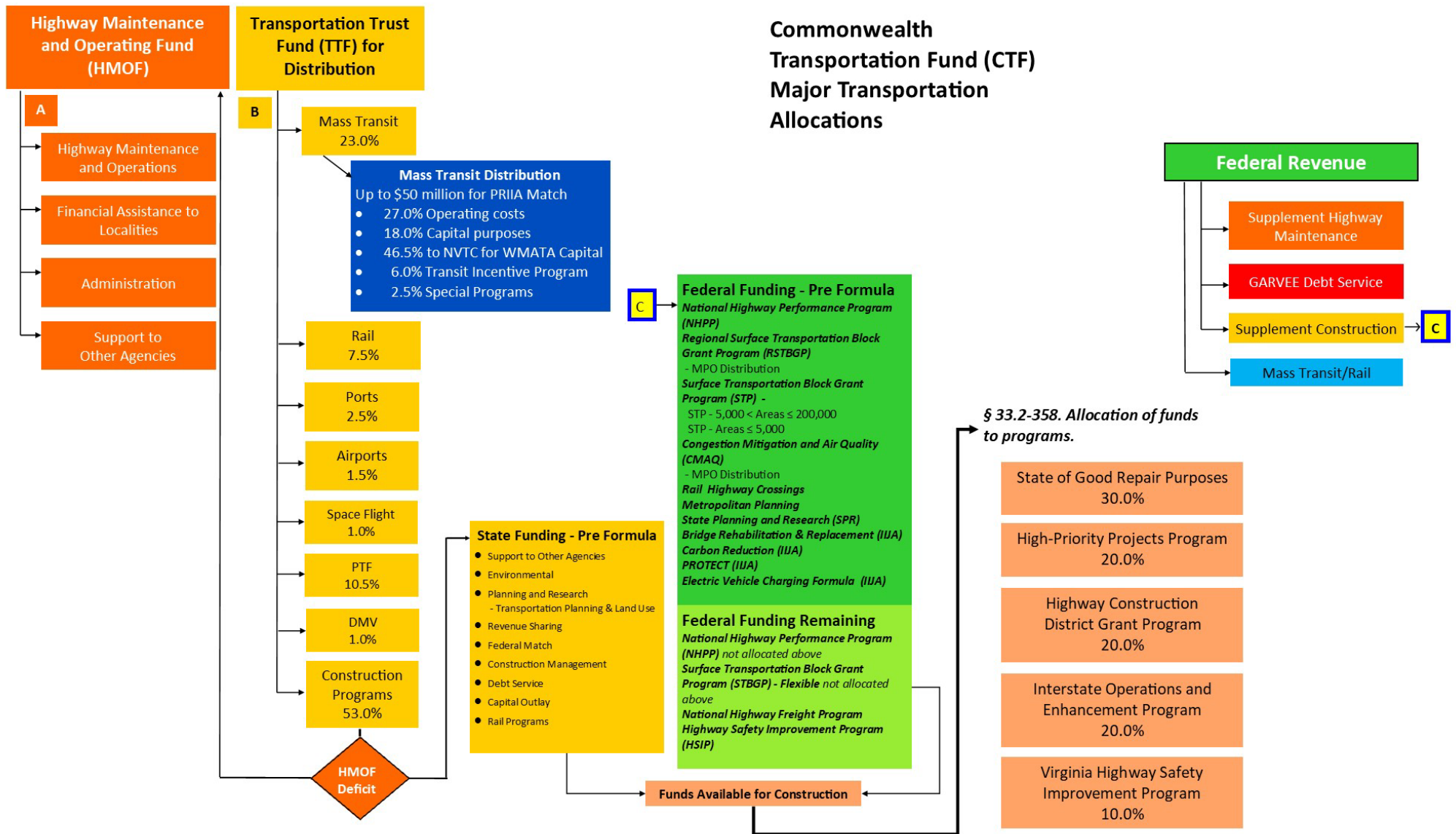

FY 2024 VDOT Budget Highlights

Draft budget totals \$7.6 billion net of regional programs; grand total of \$8.7 billion

Includes Federal Fiscal Year 2023 Earmarks for Budgeting and Programming Purposes

The Highway Maintenance and Operating Fund (HMOF) has an expected deficit of \$645 million which will be filled with \$282 million of federal funds and the crossover of \$363 million of state funds from the Construction Fund.

Highway Maintenance & Operating Fund (HMOF) Deficit (Crossover)

	FY 2022	FY 2023	FY 2024 Proposed
Federal Funding Provided to VDOT Maintenance & Operations Program	\$362.4	\$528.4	\$282.1
State Crossover (Transfer from Construction Share of TTF to HMOF)	108.7	70.0	363.0
TOTAL	\$471.1	\$598.4	\$645.1

FY 2023 Federal Funding adjusted for IIJA Implementation.

FY 2024 VDOT Recommended Allocations

	(in millions)		
	Revised FY 2023	Proposed FY 2024	Increase (Decrease)
VDOT Programs			
Environmental Monitoring and Evaluation (514)	\$ 18.0	\$ 20.0	\$ 1.9
Ground Transportation Planning and Research (602)	107.0	144.4	37.4
Highway Construction Programs (603)	3,588.6	3,649.0	60.4
Highway System Maintenance (604)	2,064.9	2,129.3	64.4
Commonwealth Toll Facilities (606)	74.6	94.0	19.5
Financial Assistance to Localities (607)			
VDOT Programs	582.1	616.6	34.5
Regional Programs	910.9	1,044.2	133.3
Non-Toll Supported Transportation Debt Service (612)	386.8	398.7	11.8
Special Structures (614)	85.0	85.0	0.0
Administrative and Support Services (699)	319.9	344.4	24.5
VDOT Capital Outlay (998)	40.0	60.0	20.0
Total VDOT Programs	\$ 8,177.8	\$ 8,585.5	\$ 407.8
Support to Other State Agencies	49.2	49.3	0.2
Support to DRPT Programs & Virginia Passenger Rail Authority	125.1	34.7	(90.3)
TOTAL	\$ 8,352.0	\$ 8,669.6	\$ 317.6
TOTAL OPERATING BUDGET (Net Regional Programs)	\$ 7,441.1	\$ 7,625.4	\$ 184.3

Next Steps



CTB to consider FY 2024 CTF, VDOT and DRPT Budgets



Monitor General Assembly Actions on any revisions to the 2022-2024 biennial budget

FY 24 Budget & Six Year Improvement Program

Commonwealth Transportation Board
June 21, 2023

Jennifer B. DeBruhl, Director



Draft vs. Final: SYIP

(In millions)

	FY 24-29 Draft	FY 24-29 Final	Change
Transit	\$4,964.5	\$4,980.3	\$15.8
Rail	\$1,367.1	\$1,368.2	\$1.1
Total	\$6,331.6	\$6,348.5	\$16.9

- Capital, Operating and Rail funding adjustments originating from actual applications and revenues accounts for the total change.

Draft vs. Final: Transit SYIP by Program

(In millions)

Program	FY 24-29 Draft	FY 24-29 Final	Change
Operating	\$1,278.3	\$1,278.6	\$0.3
Capital	\$963.7	\$978.4	\$14.7
VRE	\$85.0	\$85.0	-
WMATA	\$2,566.9	\$2,566.9	-
Other	\$70.6	\$71.4	\$0.8
Total	\$4,964.5	\$4,980.3	\$15.8

- Additional federal revenues over the six year period
- Added state match placeholder for federal discretionary awards, statewide transit marketing to support continued ridership recovery, and support for state bus roadeo/safety programs.
- Added appendix with Commuter Choice projects (no financial change)

Draft vs. Final: Rail SYIP by Program

(In millions)

	FY 24-29 Draft	FY 24-29 Final	Change
FREIGHT	\$17.1	\$17.1	-
Rail Planning	\$5.9	\$7.0	\$1.1
Rail Preservation	\$26.2	\$26.2	-
Transforming Rail	\$1,317.9	\$1,317.9	-
Total	\$1,367.1	\$1,368.2	\$1.1

- Rail Planning: \$1.1M FY29 projection omitted from Draft.

Draft vs. Final: Agency Budget

(In millions)

	FY 24 Draft	FY 24 Final	Change
Transit	\$835.0	\$836.4	\$1.4
Rail	\$25.5	\$25.5	-
Admin	\$19.6	\$19.6	-
VPRA	\$159.1	\$159.1	-
Total	\$1,039.2	\$1,040.6	\$1.4

FY 24 Budget & Six Year Improvement Program

Commonwealth Transportation Board
June 21, 2023

Jennifer B. DeBruhl, Director





FINAL FY 2024 – 2029 SIX-YEAR IMPROVEMENT PROGRAM

Kimberly Pryor
Infrastructure Investment Director

June 20, 2023

Final FY 2024-2029 Six-Year Improvement Program (SYIP)

	Draft FY 2024-2029	Proposed Final FY 2024-2029	Change
Highways*	\$19.3 billion	\$19.6 billion	0.3 billion
Rail & Public Transp.	\$6.3 billion	\$6.3 billion	0.0 billion
Total SYIP	\$25.6 billion	\$25.9 billion	0.3 billion

*Excludes debt service.

- **Highway Construction Program (FY 2024 – 2029) \$19.6 billion**
 - Additionally includes \$809 million in debt service
 - Provides funding to more than 4,700 projects
 - Current program includes \$3.0 billion to be provided by others

Highlights

- **Revenue Sharing Program continues the re-allocation of funds through FY2024 as granted by the flexibility provided during the COVID period; funds in FY2025-2029 return to \$100M annually**
- **Innovation and Technology Transportation Funds (ITTF) funding from the High Priority Projects Program is \$25M annually**
- **Unpaved roads funding from the Construction District Grant Program is \$25M annually**
- **SMART SCALE Round 5 Consensus Scenario is incorporated**
- **Inflationary cost increases on existing projects have been addressed**
- **FFY2023 federal Highway Infrastructure Program earmarks are incorporated**

Key Changes Draft to Final

- **Conducted in person Spring Public Meetings**
- **Incorporated small uplift in 5 formula programs due to fuel reserve release and debt service adjustments**
 - Uplift was allocated to balance entries for each program
- **Converted \$12.3M of FY2025 Highway Safety Improvement Program (HSIP) funds to Vulnerable Road User (VRU) funds on existing bike/ped safety projects**
 - Required by FHWA when 15 percent of the state's highway deaths were pedestrians

Key Changes Draft to Final (continued)

- **Incorporated SMART SCALE Round 5 Consensus Scenario changes approved by the Board in May**
 - Per request from the Middle Peninsula Planning District Commission in Fredericksburg District, unfunded Application 9350 for Route 17 Woods Cross Road – Davenport Road Roadway Improvements in Gloucester County for \$4.0M in High Priority Projects (HPP) funds
 - HPP funds returned to statewide balance entry
- **Updated I-81 Program based on revised estimates and debt service assumptions**
 - Removed UPC 116196 Add Northbound Lane Mile Marker 116 to 128 in Salem District from the Final SYIP due to inability to fully fund the project within the six-year window

Highlights – Impacts to Major Programs

Program	Update Cycle	Revised FY2023-2028 Total	Draft FY2024-2029 Total	Proposed Final FY2024-2029 Total
State of Good Repair Program (SGR)	Annual	\$2.2B	\$2.4B	\$2.4B
Virginia Highway Safety Improvement Program (VHSIP)	Annual	\$747.1M	\$780.2M	\$800.3M
Special Structures	Annual	\$504.4M	\$540.6M	\$540.6M
Unpaved Roads	Annual	\$150.0M	\$150.0M	\$150.0M
Innovation and Technology Transportation (ITTF)	Annual	\$150.0M	\$150.0M	\$150.0M
Regional Surface Transportation Program (RSTP)	Annual	\$837.0M	\$860.0M	\$860.0M
Congestion Mitigation Air Quality (CMAQ)	Annual	\$471.7M	\$481.1M	\$481.1M

Highlights – Impacts to Major Programs

Program	Update Cycle	Revised FY2023-2028 Total	Draft FY2024-2029 Total	Proposed Final FY2024-2029 Total
Construction District Grant (DGP) – including Supplemental Fuel Tax Revenue	Even FY's	\$2.0B	\$2.2B	\$2.2B
High Priority Projects (HPP)	Even FY's	\$1.3B	\$1.4B	\$1.4B
Interstate Operations and Enhancement Program (IOEP) – including I-81 Regional Fuels Tax	Every 4 years	\$1.7B	\$1.9B	\$1.9B
Revenue Sharing (state match only)	Odd FY's	\$805.4M	\$708.1M	\$708.1M
Transportation Alternatives (TAP)	Odd FY's	\$228.0M	\$219.9M	\$219.9M

Next Steps

- **Approve FY2024-2029 SYIP at June action meeting**



Virginia Department of Transportation



COMMONWEALTH *of* VIRGINIA
Office of the
SECRETARY *of* TRANSPORTATION

SMART SCALE Process Review Update

June 20, 2023



Overview

- **Process Bias Analysis**
 - **Project Size**
 - Small Project Preference
 - **Project Types**
 - Bike & Ped Preference
 - **Findings**
- **Scoring and Funding Analysis**
 - **One-factor Majority Impacts**
 - Land Use
 - **Funding Approach**
 - HPP Definition
 - Funding Scenario Step 2
 - **Findings**

Overview

- **Potential Process Changes**
- **Revisit Previous Recommendations**
- **Schedule and Next Steps**

Key Components of SMART SCALE Process Review



Statistical Analysis

Analysis of the performance and outcomes of the past funding rounds

Identification of potential biases and related causes



Survey Assessments

Review of process performance and perceptions

Administration, communications, and customer service



Procedural Review

Identify procedural improvements including application updates, communications, and process improvements



Code and Policy

Recommend procedural changes

Recommend CTB Policy changes

Recommend Code changes

Process Bias Analysis

Small Project Preference



- One area of perceived bias identified in the SMART SCALE Process Review Survey responses was “Small Project.”

“Do you think the current process is biased in any way (urban/rural, large/small projects, mode, etc.)?” (yes/no & free text response)

Yes

59%

of external respondents think *the current process is biased in some way*

No

41%

of external respondents think *the current process is not biased in some way*

Process Bias Analysis

Small Project Preference



- **When referring to “Small Projects”, interpreted as low-request (<\$10M)**
 - 60% of all applications are Small Projects
 - 95% of Small Projects have a total cost of less than \$10M
- **Small Projects vs. Large Projects comparison**
 - 1,092 Small Projects submitted / 823 Large Projects submitted
 - \$4.8B Small Projects requested / \$33.1B Large Projects requested
 - 558 Small Projects funded* / 154 Large Projects funded
 - \$2.1B Small Projects funded / \$4.2B Large Projects funded

**The term “funded” represents projects recommended for funding in the staff scenario throughout the presentation*

Process Bias Analysis Funded Small Projects



- Based on the number of projects, Small Projects were just over 2X more successful than larger projects.
- The average project funded amount is \$8.9M.
- The average amount requested for all projects is \$19.8M.

Success rate for Small Projects across all area types (558 projects)

51%

Success rate for projects greater than \$10M across all area types (154 projects)

19%

Process Bias Analysis

Funded Small Projects

- Small Projects account for 78% of all funded projects.
- Small Projects account for 33% of the total funded amount.

Small Funded Projects vs. Large Funded Projects, with Total Funded Projects

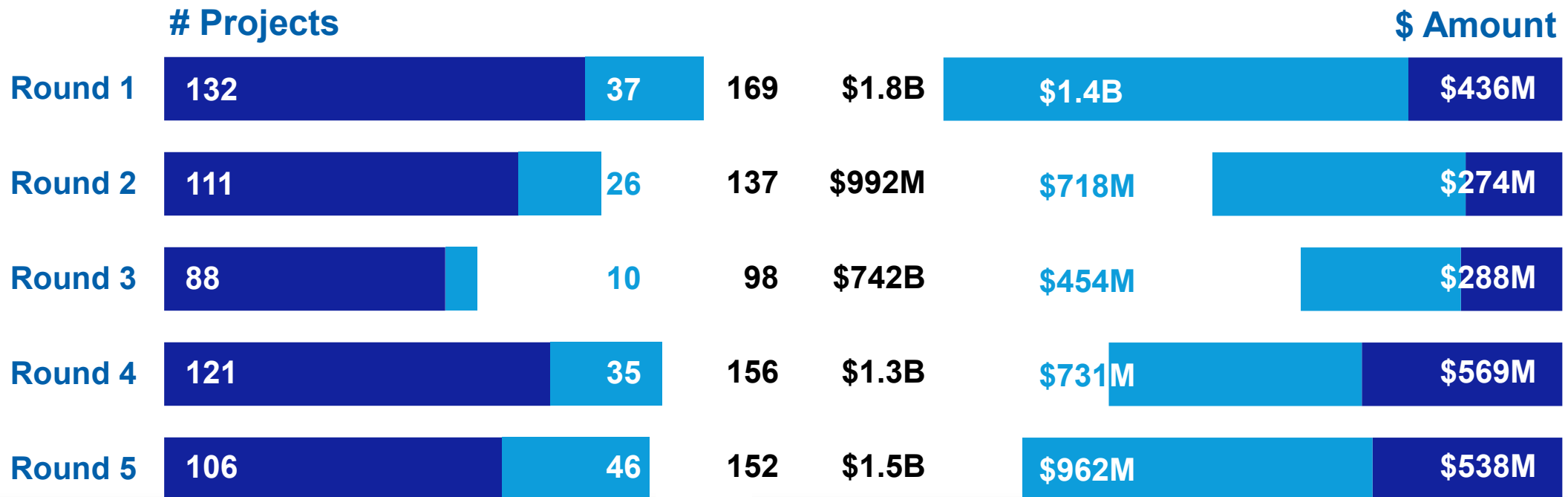

Process Bias Analysis

Funded Small Projects by Program - Counts



- Overall, based on the number of projects, most funded projects in both DGP and HPP are small.
- In HPP, based on the number of projects, 60% are small.

of Funded Projects (DGP and HPP)

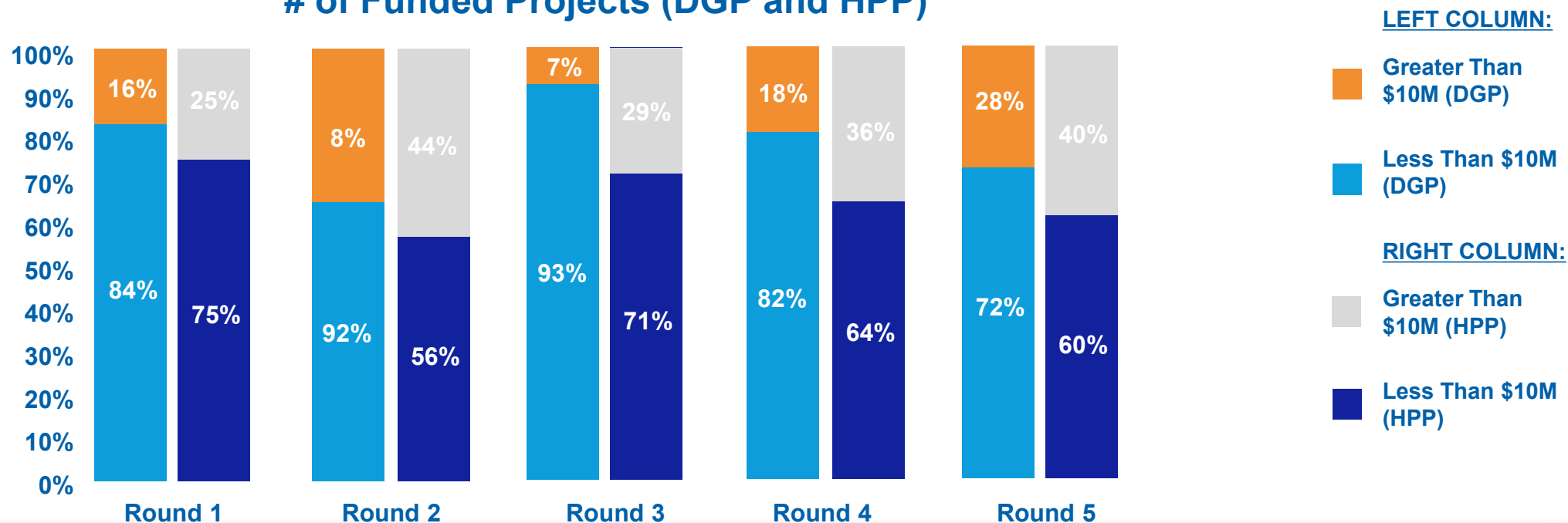

Process Bias Analysis

Funded Small Projects by Program - \$ Amount



- In DGP, Small Projects are getting roughly equal the amount of funding compared to larger projects.
- In HPP, the funded amount of Small Projects in Rounds 4 & 5 was 21% higher than in Rounds 1, 2, & 3 combined.

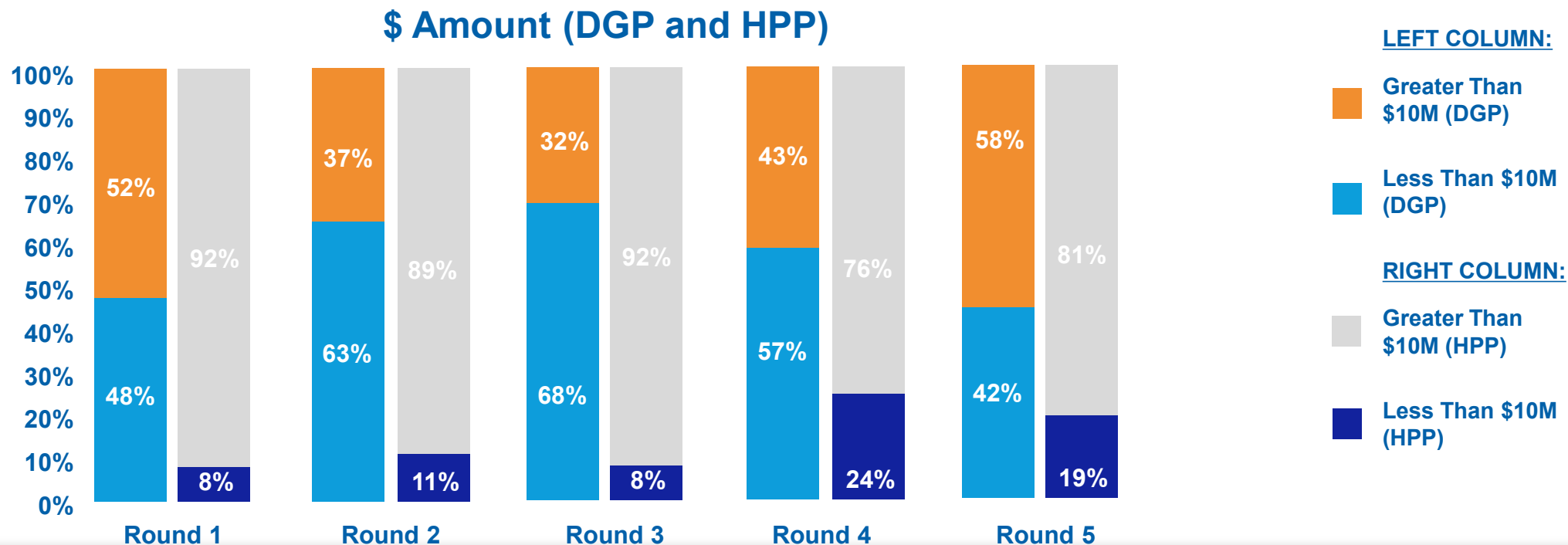

Process Bias Analysis

Types of Small Projects



- **Typical Small Projects may include**

- Highway Principal Improvement Type* – Intersection or turn lane improvements, innovative intersections, roadway widenings, access management
 - Typically, less than a half mile in length
- Bike & Ped Principal Improvement Type – Sidewalk projects, shared-use paths, bike lanes, improve crossings
 - Typically, less than 1 mile in length
- Bus Transit Principal Improvement Type – New Routes, Stop Improvements

**Principal Improvement Type means the largest component of the application. SMART SCALE applications are largely multi-modal with 50% of all Highway Principal Improvement Type projects having Bike & Ped components.*

Process Bias Analysis

Prevalence of Bike & Ped Projects



- **For all Small Projects (all principal improvement types):**
 - Highway projects comprise 74% of projects submitted (804 out of 1,092 projects)
 - Highway projects comprise 67% of funded projects (376 out of 558 projects)
 - Bike & Ped projects comprise 21% of projects submitted (228 out of 1,092 projects)
 - Bike & Ped projects comprise 24% of funded projects (135 out of 558 projects)

Process Bias Analysis

Success of Bike & Ped Projects



- Overall, small Bike & Ped projects were more successful than small Highway projects.

Small Projects (Funded vs. Unfunded) and Submitted, with **Success Rate**
 # Projects \$ Amount

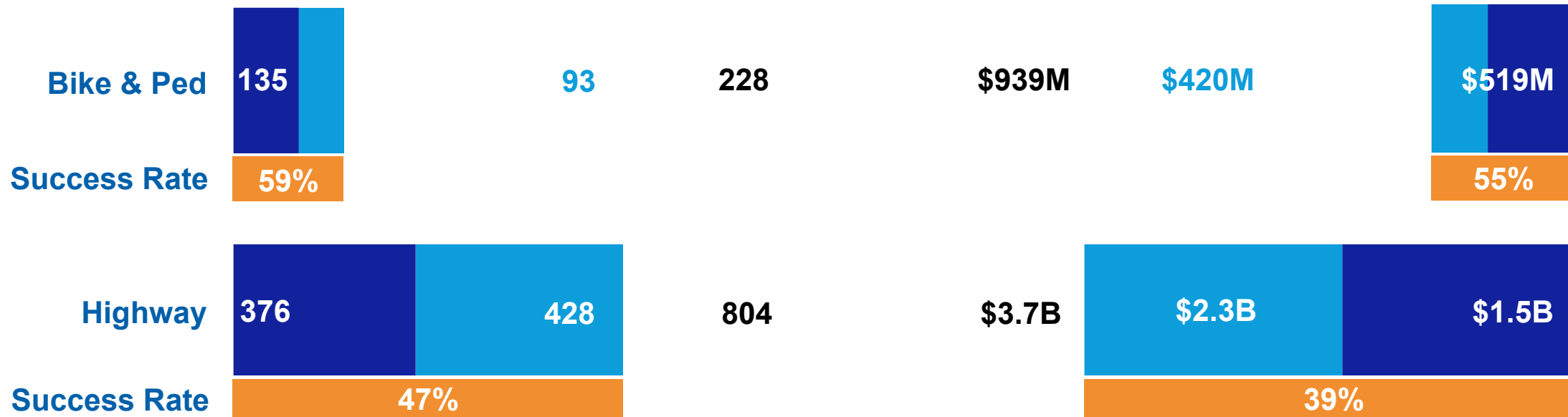

Process Bias Analysis

Number of and Funding for Small Bike & Ped Projects



- Small Bike & Ped projects have steadily increased in terms of number of projects and funding amounts both submitted and recommended.

Funded Small Bike & Ped vs. Unfunded Small Bike & Ped, with Total Submitted Small Bike & Ped

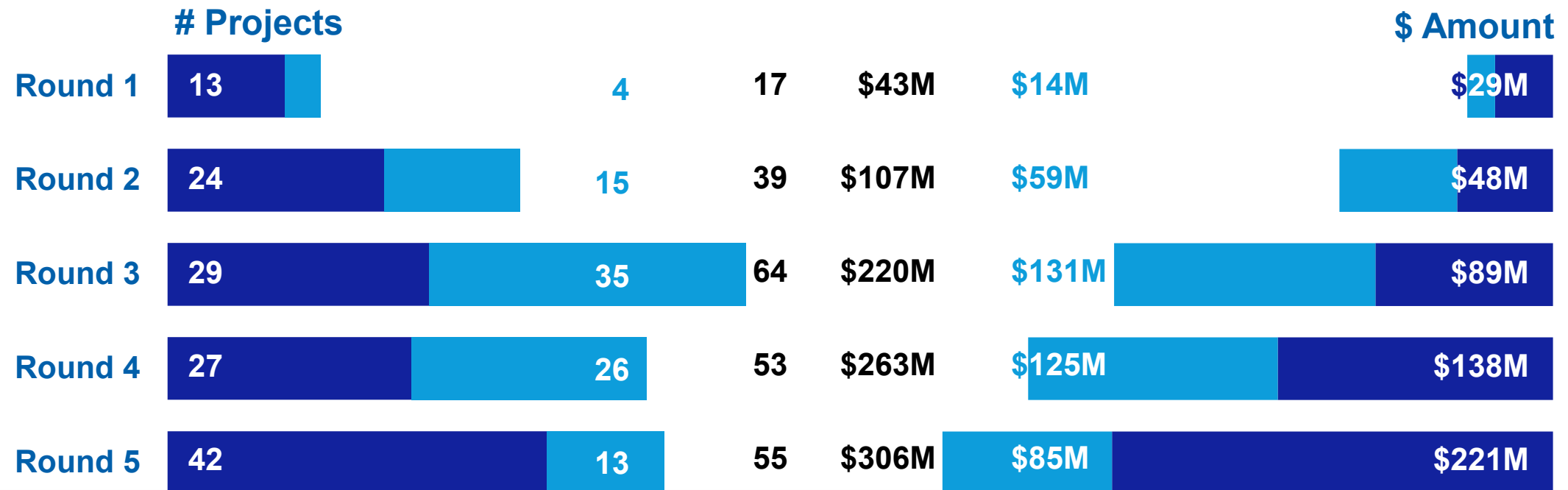

Findings

Small Project Size Perception



- **Small Projects were funded just over 2X more often than larger projects**
- **Overall, small Bike & Ped projects were more successful than small Highway projects**
- **Small Projects account for 78% in project count and 33% of the total funded amount**
 - Bike & Ped projects received 25% of the total funding for Small Projects compared to 69% for Highway projects
- **Average SMART SCALE request has decreased between Rounds 1 and 4**
- **Bike & Ped projects have steadily increased in terms of the number of projects and funding amounts both submitted and recommended**
 - Funded amounts for Bike & Ped projects increased in HPP in Rounds 4 and 5

Scoring and Funding Analysis

- 
1. In the Scoring Process – Land use factor contributes significantly to funded projects scores
 2. In the Funding Scenario Process - HPP dollars facilitate funding small project request projects

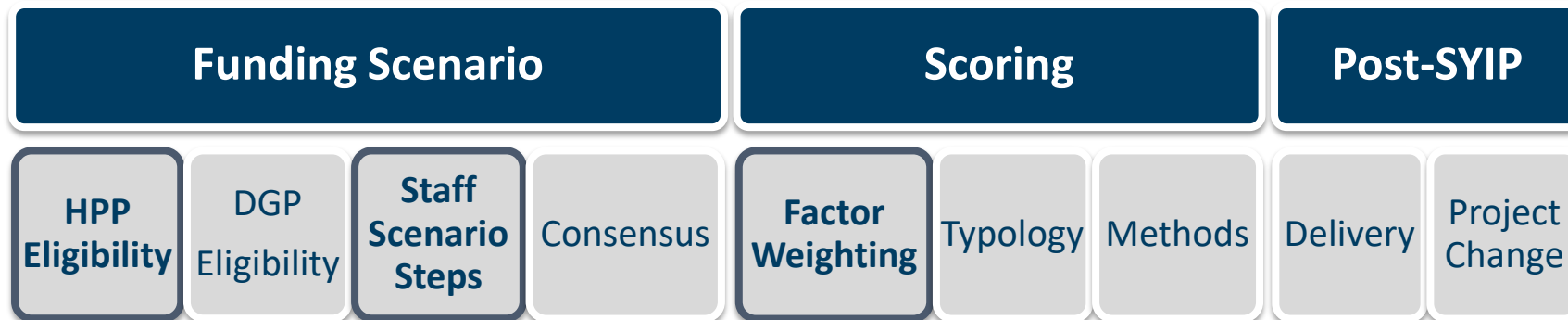

- Adjusting in one area can affect another
- A singular issue identified might be resolved by adjusting multiple components of the process
- A singular process adjustment might resolve multiple issues

Scoring and Funding Analysis

One-factor Majority Impact



- Land Use factor drives total benefits, at a rate of 2X from Round 1 to Round 5
- Land Use was expanded to Type C & D in Round 5

Percent of Funded Project Benefit by Factor Area

Round	Safety	Congestion	Accessibility	Land Use	Economic Development	Environment
1	28%	9%	2%	23%	24%	14%
2	28%	15%	6%	24%	18%	10%
3	37%	5%	4%	24%	16%	15%
4	36%	8%	6%	31%	7%	12%
5	28%	5%	7%	49%	4%	7%

Greater than 40% of total benefit score

Scoring and Funding Analysis

One-factor Majority Impact

In Small Projects



- In round 5, the smaller the project, the greater the Land Use benefit

Percent of Land Use Benefit by Funded Project Cost

Round	Applicable Area Type	ALL	<\$10M	\$10M-\$20M	\$20M-\$30M	\$30M-\$40M	\$40M-\$50M	>\$50M
1	AB	23%	21%	35%	35%	10%	2%	7%
2	AB	24%	25%	22%	21%	0%	-	8%
3	AB	24%	24%	19%	-	0%	-	30%
4	AB	31%	32%	24%	67%	18%	9%	8%
5	ABCD	49%	55%	43%	32%	7%	-	0%

Greater than 40% of total benefit score

Scoring and Funding Analysis

One-factor Majority Impact

In Bike & Ped Projects



- Compared to all types, Bike & Ped projects have the most Land Use benefit
- Twice the amount in Bike & Ped when compared to Highway projects

Percent of Land Use Benefit by Funded Project Type

Round	ALL	Bike/Ped	Highway	Bus Transit	Rail Transit	TDM
1	23%	49%	19%	35%	95%	17%
2	24%	40%	18%	35%	13%	46%
3	24%	28%	17%	41%	69%	54%
4	31%	60%	20%	60%	8%	38%
5	49%	74%	37%	64%	-	-

Greater than 40% of total benefit score

Scoring and Funding Analysis

One-factor Majority Impact

Current Land Use Scoring Methods

Scoring

Factor
Weighting

Typology

Methods

- **Current Land Use method is more related to project location than to expected project outcomes**
 - Scores existing walk access to key non-work destinations such as grocery, healthcare, education, etc. in the vicinity of the proposed transportation improvement
 - Weighted based on population and employment density
- **Land Use was expanded to Type C & D in Round 5**
- **In Round 5 - funded projects a significant portion of overall benefit points from Land Use**
 - 77 projects funded (out of 152) had over 50% of the benefit score from Land Use
 - Of those 40 projects funded had over 80% of the benefit score from Land Use

Potential Process Changes Modifications to Land Use Factor

Scoring

Factor
Weighting

Typology

Methods



- **Modify the Factor Weighting for the Land Use factor**
- **Adjustments to other factor areas (will be discussed in July)**

- **Continue to use Land Use Factor to encourage land-use and transportation coordination**
- **No change to the way Land Use is calculated today**
- **Modify how Land Use weighting is applied**
 - Enhances the benefits of the project based on where it is located
 - Land Use Factor would be used to increase benefit points in other factor areas
 - Prevents Land Use from being the sole driver of success

Potential Process Changes

Modifications to Land Use Factor - Scenario

Scoring

Factor
Weighting

Typology

Methods



- **Funded Small Projects were reduced from 106 to 41.**
- **Funded Bike & Ped Principal Improvement Types were reduced from 51 to 20.**

The average total cost of funded projects raised from \$15.1M to \$18.3M

The average total request of funded projects raised from \$10.1M to \$11.8M (removes 28 projects)

For Principal Improvement Type

- **Bike & Ped - 51 to 20**
- **Highway - 98 to 102**
- **Bus Transit - 3 to 2**

For Area Type

- **A - 39 to 29**
- **B - 34 to 24**
- **C - 23 to 19**
- **D - 56 to 52**

Potential Process Changes

Refine HPP Definition

Funding Scenario

HPP
Eligibility

DGP
Eligibility

Steps

Consensus



- Refine the HPP definition, which is largely implemented through CTB Policy.
- Current CTB Policy defines the *where* through VTrans, but not the *what*.

- **Code of Virginia § 33.2-370**
 - “High-priority projects” means those **projects of regional or statewide significance**, such as projects that reduce congestion or increase safety, accessibility, environmental quality, or economic development”
- **Policy defines where - Corridors of Statewide Significance and Regional Networks**
- **Define what**
 - Consider projects that **include** feature types - New Capacity Highway, Managed Lanes, New or Improved Interchanges, New or Improved Passenger Rail Stations or Service, Freight Rail improvements, Fixed Guideway Transit

Potential Process Changes

Current Funding Steps

Funding Scenario

HPP
Eligibility

DGP
Eligibility

Steps

Consensus



- Funding Small Projects with HPP dollars.

- Allocation steps are used to develop staff recommended funding scenario
 - Step 1 allocates DGP on a district-wide basis
 - Step 2 allocates HPP on a district-wide basis
 - Step 3 allocates HPP on a statewide basis
- HPP has not grown since Round 2, however, the DGP is now enhanced by the Supplemental District Grant (SDG) revenues

Potential Process Changes

Eliminate Step 2

Funding Scenario

HPP
Eligibility

DGP
Eligibility

Steps

Consensus

- Eliminate Step 2, Prioritize all HPP statewide by SMART SCALE Score.
- Smaller projects are being submitted as Step 2 eligible (MPO/PDC/Transit Only).
- Small Bike & Ped submitted in Step 2 has increased from 1 (RD 1&2) to 32 RD 5.

Step 2 Eligible by Round

Round	Step 2 Eligible Number Submitted	Step 2 Eligible Average Request	Step 2 Eligible Number Funded	Step 2 Eligible Average Funded
1	48	\$57M	23	\$4 M
2	45	\$37 M	10	\$2 M
3	72	\$38 M	11	\$7 M
4	82	\$16 M	33	\$8 M
5	81	\$ 19 M	28	\$10 M

Potential Process Changes

Refine HPP Definition - Scenario

Funding Scenario

HPP
Eligibility

DGP
Eligibility

Steps

Consensus

- 
- Steps 2 and 3 average project size rose from \$15.6M (30 projects) to \$76.2M (6 projects).
 - All Bike & Ped Principal Improvement Types were removed from HPP.

The average total cost of funded projects rose from \$15.1M to \$18.0M

The average total request of funded projects rose from \$10.1M to \$11.8M (removes 24 projects)

For Principal Improvement Type

- Bike & Ped - 51 to 38
- Highway - 98 to 88
- Bus Transit - 3 to 1

For Area Type

- A - unchanged at 39
- B - 34 to 24
- C - 23 to 17
- D - 56 to 48

Potential Process Changes

Eliminate Step 2 - Scenario

Funding Scenario

HPP
Eligibility

DGP
Eligibility

Steps

Consensus



- SMART SCALE review highlighted favor of Small Projects.
- Smaller projects get funded in both DGP and HPP.
- Importance of refining the definition of HPP-eligible project.

The average total cost of funded projects fell from \$15.1M to \$11.1M

The average total request of funded projects fell from \$10.1 M to \$9.8 M (adds 14 projects)

For Principal Improvement Type

- **Bike & Ped** - 51 to 56
- **Highway** - 98 to 107
- **Bus Transit** - unchanged at 3

For Area Type

- **A** - 39 to 42
- **B** - 34 to 40
- **C** - 23 to 28
- **D** - unchanged at 56

Potential Process Changes

Potential Solutions Combined

Funding Scenario

HPP
Eligibility

DGP
Eligibility

Steps

Consensus

- 
- Combining the scenarios balances the two HPP solutions.
 - HPP average funded went from \$15.6M (30 projects) to \$31.8M (17 projects).
 - Bike & Ped Principal Improvement types reduced from 51 to 15.

The average total cost of funded projects rose from \$15.1M to \$20.5M

The average total request of funded projects rose from \$10.1M to \$13.2M (removes 34 projects)

For Principal Improvement Type

- **Bike & Ped** - 51 to 15
- **Highway** - 98 to 103
- **Bus Transit** - 3 to 0

For Area Type

- **A** - 39 to 30
- **B** - 34 to 26
- **C** - 23 to 18
- **D** - 56 to 44

Revisit Previous Recommendations

Application Cap Limit

Addresses Small Project Bias

- Forces applicants to prioritize submissions focused on priorities.
- In the testing scenario, the overall project cost/size was increased in funded projects.
- Anticipate reduction in Small Projects as a result of cap limit reduction.

Schedule and Next Steps

JUNE

Process Biases (Part 1), One Factor Majority, Funding Steps

SEPT

Retreat Summary, Disconnect Between Need and Benefit, Flexibility in Project Change Process, Project Performance

JULY

Process Biases (Part 2), Low Scoring Projects, Emphasis on Safety Priority, Forward-Looking Process

OCT

Final Recommendations

**JULY
Retreat**

Summarize findings to date and gather feedback, Identify any additional focus areas of analysis, Discuss preliminary recommendations

NOV

TBD

AUG

No Meeting

DEC

Policy Adoption



COMMONWEALTH *of* VIRGINIA
Office of the
SECRETARY *of* TRANSPORTATION



VIRGINIA DEPARTMENT OF RAIL
AND PUBLIC TRANSPORTATION





COMMONWEALTH of VIRGINIA
Office of the
SECRETARY of TRANSPORTATION

Draft VTrans Vision, Goals, and Guiding Principles

Jitender Ramchandani
Statewide Transportation Planning Manager
Office of Intermodal Planning and Investment (OIPi)

June 20, 2023



PURPOSE OF THE PRESENTATION

- ▶ Summarize VTrans items presented in April and May CTB Workshops
 - ▶ Draft Vision, Guiding Principles and Goals
- ▶ Outline Next Steps



VTRANS FOCUS AREAS

CTB Vision, Guiding Principles, Goals and Objectives

Mid-term Needs and Priority Locations (0 – 10 Years)

Long-term Risk & Opportunity Register (20+ Years)

Strategic Actions (Recommendations)

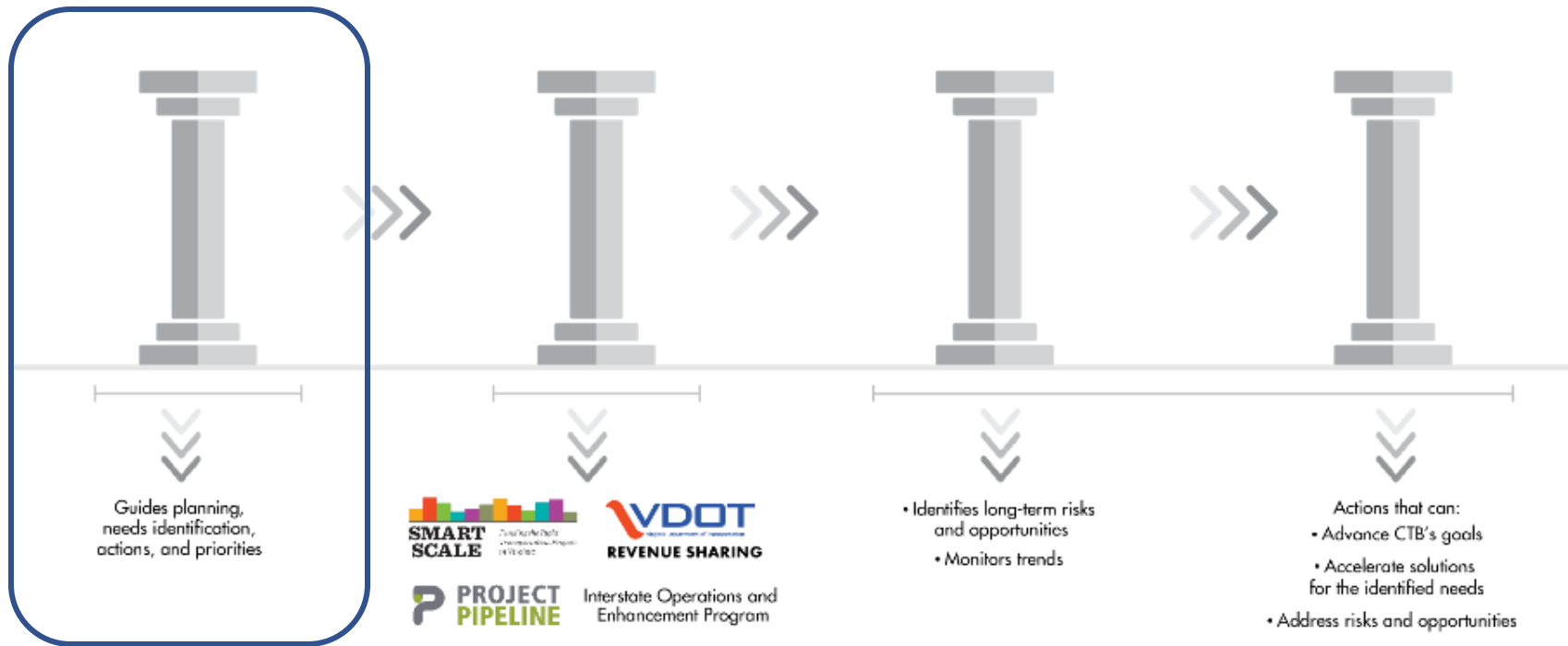

- ▶ **Virginia's best-in-class multimodal transportation system provides safe and reliable mobility, connects people and commerce, fosters economic growth and investment, and enhances quality of life.**



REVISED GUIDING PRINCIPLES

GP 1: Optimize Return on Investments: Implement the right solution at the right price to meet identified needs while advancing long-term prosperity and livability.

GP 2: Ensure Safety, Security, and Resiliency: Provide a safe transportation system for all users that responds immediately to short-term events such as weather or security emergencies and adapts effectively to long-term issues (e.g., resiliency).

GP 3: Efficiently Deliver Programs: Deliver high-quality projects and programs in a cost-effective and timely manner.

GP 4: Consider Operational Improvements and Demand Management First: Maximize the capacity of the transportation network through increased use of technology and operational improvements and demand for the system before investing in major capacity expansions.

GP 5: Ensure Transparency, Accountability, And Promote Performance Management: Work with stakeholders in developing transportation plans and programs. Establish performance targets, measure progress, and adjust programs and policies as necessary.

GP 6: Enhance Coordination Between Transportation and Land Use: Collaborate with local governments to plan and manage transportation-efficient land use.

GP 7: Ensure Efficient Intermodal Connections: Provide seamless connections between modes of transportation.

DRAFT GOALS

DRAFT GOALS

Goal A: Transportation System Safety: Significantly reduce fatalities and serious injuries.

Goal B: System Preservation: Provide well-maintained and managed transportation infrastructure and services across the Commonwealth.

Goal C: Congestion and Travel Time Reliability: Improve travel time reliability by minimizing congestion and providing multiple modes and routes.

Goal D: Inter-connected Systems and Services: Provide an integrated multimodal transportation system for better accessibility and travel options.

NEXT STEPS

► Jul: Present Draft Objectives



Sept: Request action on Vision, Goals, Objectives, and Guiding Principles

► Oct: Present Draft VTrans Mid-term (0 – 10 years) Needs



Dec: Request approval of 2023 VTrans Mid-term Needs





Director's Report

June 2023



Administrative Highlights

Maximum Employment Level: 72

Current Vacancy Rate: 17 percent

Goal: Eight percent

New Hires:

Deanna Oware, Chief Financial Officer (Start Date: June 10)

Shannon Girouard, Senior Grants Analyst (Start Date: June 25)

Paige Lazar, Statewide Transit Planner (Start Date: July 10)



Rail Highlights

Awards

- The 2022 State Rail Plan won **Best Digital Application** at the Virginia Association for Mapping and Land Information Systems (VAMLIS) 2023 Conference.
- The 2022 State Rail Plan won **Best Storymap Application** at the American Association of State Highway and Transportation Officials (AASHTO) GIS-Transportation 2023 Conference.
- The Official Virginia State Rail Map won the **People's Choice Award** at the AASHTO GIS-T Conference.
- DRPT awarded **\$3.2M** from the inaugural FRA Railroad Crossing Elimination Program to improve safety at 4 rural crossings along the DC2RVA corridor ([seen on map](#))

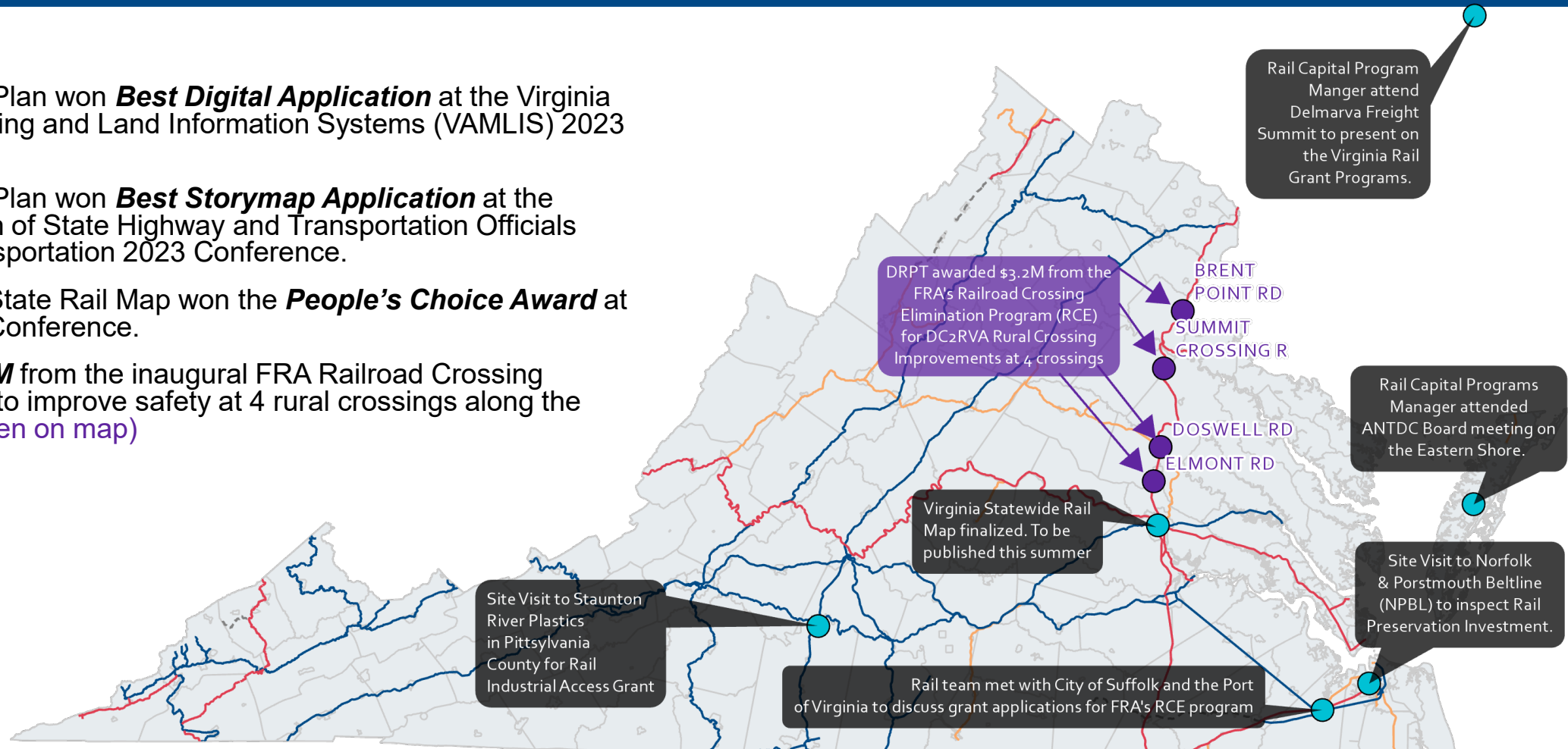

Rail Highlights

- Updated Official Virginia State Rail Map complete
- To be printed this summer and distributed across the Commonwealth

DRPT Connects
Virginia railways do more than move people and goods from here to there. They connect us to what matters most.

TRANSFORMING VIRGINIA
For over 50 years the Department of Rail and Public Transportation has worked to connect Virginians to innovative and accessible transportation.

Through an ambitious initiative known as Transforming Rail in Virginia, the Commonwealth purchased approximately 400 miles of right-of-way to expand passenger rail service.

Through collaboration with partners such as the Port of Virginia and industry leaders, Virginia's freight rail corridors will be better supported to meet the needs of our communities. These initiatives aim to improve the quality of life for all Virginians.

Virginia Right of Way and Track Acquisition

- BNSF Line (Washington Peninsula) 2011 (not original right-of-way)
- I Line (Dorchester-Hampton) 2012
- Richmond & Albemarle (Dorchester Peninsula) 2012
- Virginia Line (Dorchester Peninsula) 2012

OFFICIAL VIRGINIA STATE RAIL MAP

LEGEND

Rail Line Operator

Rail Line Operator	Reporting Mark
Buckingham Branch	BSB
Chesapeake & Albemarle	CA
Chesapeake Western	CSW
Commonwealth Railway	CRW
Dalhousie Central	DCR
Frontier & Cumberland Gap	FCG
North Carolina & Virginia	NCVA
Roanoke & Portsmouth Belt Line	RPL
Shenandoah Valley	SV
Washington & Northern	WN
CSX Transportation	CSX
Norfolk Southern	NS

Passenger Service

Passenger Service	Reporting Mark
Amtrak	AMTK
Virginia Railway Express	VRE

Trackage Rights

Trackage Rights	Reporting Mark
Amtrak	AMTK
Virginia Railway Express	VRE
Amtrak Connector Bus	AMTK
Virginia Railway Express Station	VRE
Rail to Trail	RTT
Abandonment or Discontinuation	AD
CSX Trackage	CSX
Norfolk Southern Trackage	NS
Short Line Routes	SLR

Rail Highlights

Redesigned back/folded side view

ROLLING ALONG VIRGINIA'S ROADS AND RAILWAYS

Virginia hosts a robust transportation network. Use these resources to travel our stunning Commonwealth.

- Amtrak**
Offering nationwide passenger rail service.
amtrak.com
- Virginia Railway Express**
Commuter rail serving Northern Virginia and Washington D.C.
vire.org
- Virginia Breeze**
Intercity bus travel connecting the Commonwealth.
virginiabreeze.org
- Virginia Passenger Rail Authority**
The Virginia Passenger Rail Authority (VPRRA) is responsible for promoting, sustaining, and expanding the availability of passenger and commuter rail service in the Commonwealth. VPRRA partners with CSX and NS to construct new railroad projects, and with Amtrak and VRE to deliver service throughout Virginia.
vapassengerauthority.org
- The Port of Virginia**
The Port of Virginia delivers opportunity by driving business to and through the Commonwealth. The Port operates five water terminals and one inland port.
portofvirginia.com
- DRPT**
Virginia Department of Rail and Public Transportation
The Department of Rail and Public Transportation (DRPT) is the catalyst to connect and improve the quality of life for all Virginians through innovative transportation solutions.
drpt.virginia.gov

Learn more about all our transportation partners at drpt.virginia.gov

FREIGHT AND PASSENGER RAILROADS OF THE EASTERN UNITED STATES

Save Money

\$2.1B in annual benefits
\$133.4M in annual benefits

Benefits are largely derived by diverting freight and passenger from highways to rail.

Breathe Easier

On average, railroads are four times more fuel efficient than trucks.

Moving freight by rail instead of truck generates **75% less greenhouse gas emissions**.

2.4M tons of CO₂ emissions avoided (5% of total in Virginia per year)

Benefits of Rail in Virginia

We all benefit when Virginia invests in rail initiatives that promote safety, encourage economic prosperity, increase accessibility to service, and support healthy communities with sustainable transportation.

Visit the 2022 Virginia Statewide Rail Plan to learn more.

Relieve Congestion

\$231M Annual congestion savings

\$85M Annual pavement maintenance savings

Travel Safely

Shipping by rail avoids about **15B miles** of truck travel in Virginia.

Passenger travel by rail avoids about **266M miles** of personal travel in Virginia.

\$65M Saved from reducing crash-related accidents, injuries, and deaths.

ROANOKE

LYNCHBURG

FREDERICKSBURG

CHARLOTTESVILLE

NORTHERN VIRGINIA

RICHMOND

HAMPTON ROADS

NEWPORT NEWS

EASTERN SHORE

PASSENGER RAIL IN VIRGINIA

LEGEND

Rail Line Operator	Reporting Mark
Buckingham Branch	BB
Chesapeake & Albemarle	CA
Chesapeake Division	CD
Commonwealth Railway	CHW
Delmarva Central	DC
Kenilworth & Cumberland Gap	KCCG
Norfolk & Pamlico	NPA
Norfolk & Portsmouth Belt Line	NPBL
Shenandoah Valley	SV
Westchester & Western	WW
CSX Transportation	CSX
Norfolk Southern	NS

Passenger Service	Reporting Mark
Amtrak	AMTK
Virginia Railway Express	VRE

Trackage Rights

- Multiple Owner Highway
- Ten Line Highway
- Ten Line Priority Road
- Katapult
- Abandoned or Discontinued
- Port of Virginia
- Commonwealth
- State Capital
- National Capital
- Class 1 Route
- Military Access
- State & Regional Paths
- State Boundary
- County Boundary

Connecting what matters most.

VIRGINIA RAILROADS

Official Virginia State Rail Map

DRPT
Department of Rail and Public Transportation

Our Vision is a connected Commonwealth with an integrated, efficient network that serves every person, every business, and every need.

Commonwealth of Virginia
Oliver Youngkin
Governor

W. Shipyard Keller III
Secretary of Transportation

Caroline O'Connell
Under Secretary of Rail and Public Transportation

Department of Rail and Public Transportation
600 Commonwealth Building
Richmond, Virginia 23260
804.744.7000
www.drpt.virginia.gov

© 2022 Department of Rail and Public Transportation
VIRGINIA.GOV

Public Transportation Highlights

- HJ542 Study
 - ACEC National Recognition Award
- Virginia Railway Express is nearing completion of the rehabilitation of its Lifecycle Overhaul and Upgrade (LOU) Facility.
 - Once completed, the facility will provide VRE the ability to perform an expanded range of maintenance activities, including heavy work on locomotive parts, that cannot be done in its current facility.
 - This will save a tremendous amount of time and money in eliminating the need to ship parts out of state for repair.
 - The facility also has the most modern safety features that allow maximum protection to technicians performing the work.
- Mountain Empire Transit, located in Big Stone Gap, recently experienced its highest ridership day to date on the METGo! microtransit service.
 - The route that serves Norton and Wise provided more than 300 trips one day.
 - The service was started with the help of an award in 2021 from DRPT and Mountain Empire has started planning for additional routes.
- The “Relay” project in Fairfax County, a pilot project to operate an electric driverless shuttle in the Mosaic District of the County, has concluded after two-year run.
 - The data and findings from the project will be used to determine the potential of expanding the use of driverless vehicle technology.
 - The project was the result of a partnership between DRPT, VDOT, Virginia Tech, and George Mason University.

Statewide Transit Ridership

Statewide Transit Ridership – May 2022 to April 2023

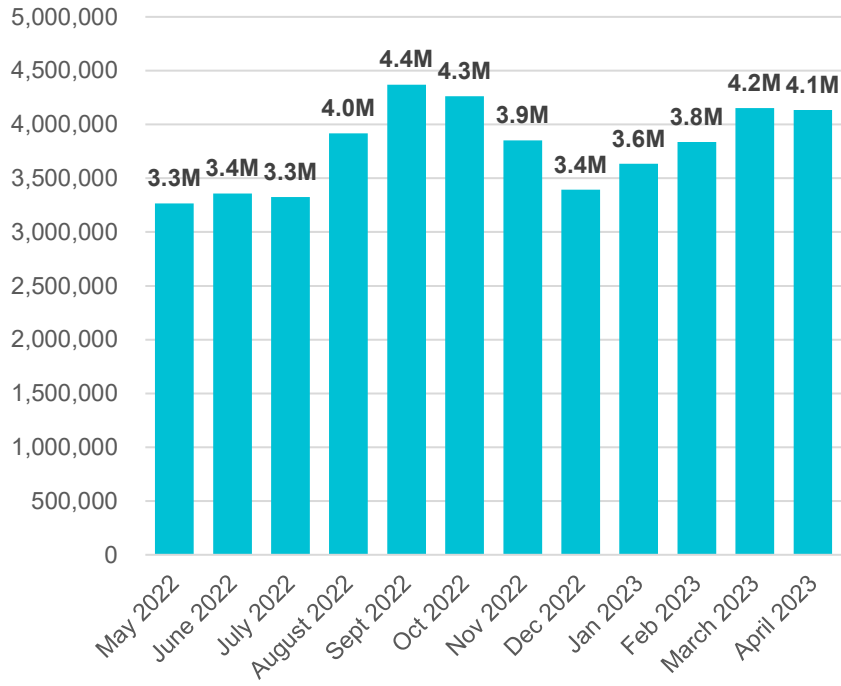

Virginia Agencies

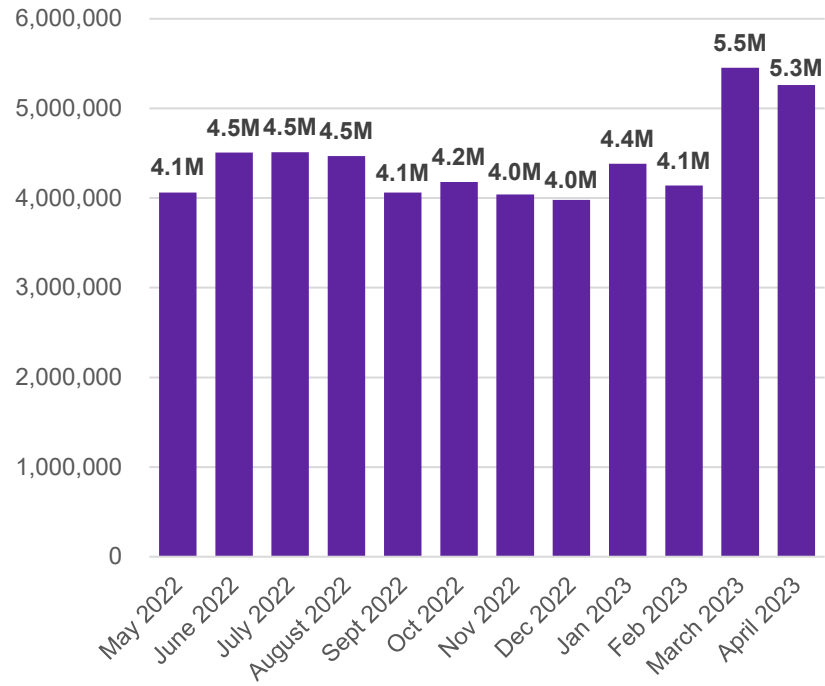

WMATA

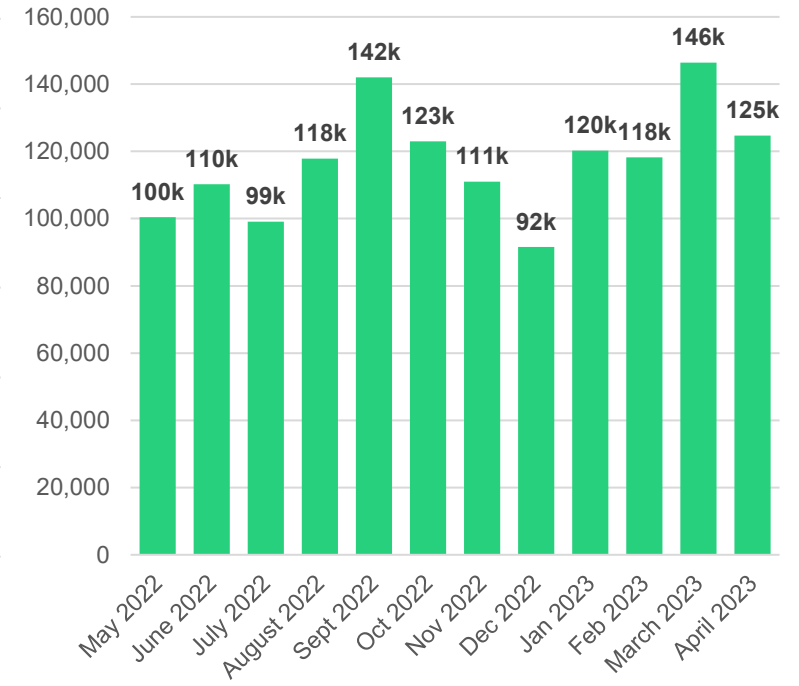

VRE

Agencies	May 2022	June 2022	July 2022	August 2022	Sept 2022	Oct 2022	Nov 2022	Dec 2022	Jan 2023	Feb 2023	March 2023	April 2023	Total
Virginia Agencies	3,264,947	3,357,208	3,325,328	3,918,682	4,370,401	4,261,450	3,850,933	3,393,853	3,635,189	3,837,051	4,152,675	4,134,215	45,501,932
VRE	100,424	110,208	99,120	117,880	141,963	122,984	111,028	91,597	120,228	118,181	146,391	124,664	1,404,668
WMATA	4,062,153	4,505,702	4,509,235	4,466,511	4,061,584	4,178,637	4,040,866	3,979,130	4,380,844	4,137,898	5,451,449	5,258,278	53,032,287
All Agencies + VRE + WMATA	7,427,524	7,973,118	7,933,683	8,503,073	8,573,948	8,563,071	8,002,827	7,464,580	8,136,261	8,093,130	9,750,515	9,517,157	99,938,887

April Statewide Ridership Comparison: Year-to-Year

Transit ridership for Virginia agencies in April 2023 was 19% higher than April 2022.

- Bus ridership was 21% higher

April 2023 ridership for Virginia agencies was 74% of pre-pandemic April 2019 levels.

- Bus ridership was 72% of 2019 levels

VRE ridership in April 2023 was 36% higher than April 2022 and 30% of pre-pandemic April 2019 levels.

WMATA ridership in April 2023 was 34% higher than in April 2022.

- Bus ridership was 16% higher
- Heavy rail (Metro) was 40% higher

April 2023 WMATA ridership was 52% of pre-pandemic April 2019 levels.

- Bus ridership was 68% of 2019 levels
- Heavy rail (Metro) is 50% of 2019 levels

April Ridership Comparison: Year-to-Year
2020 – 2023

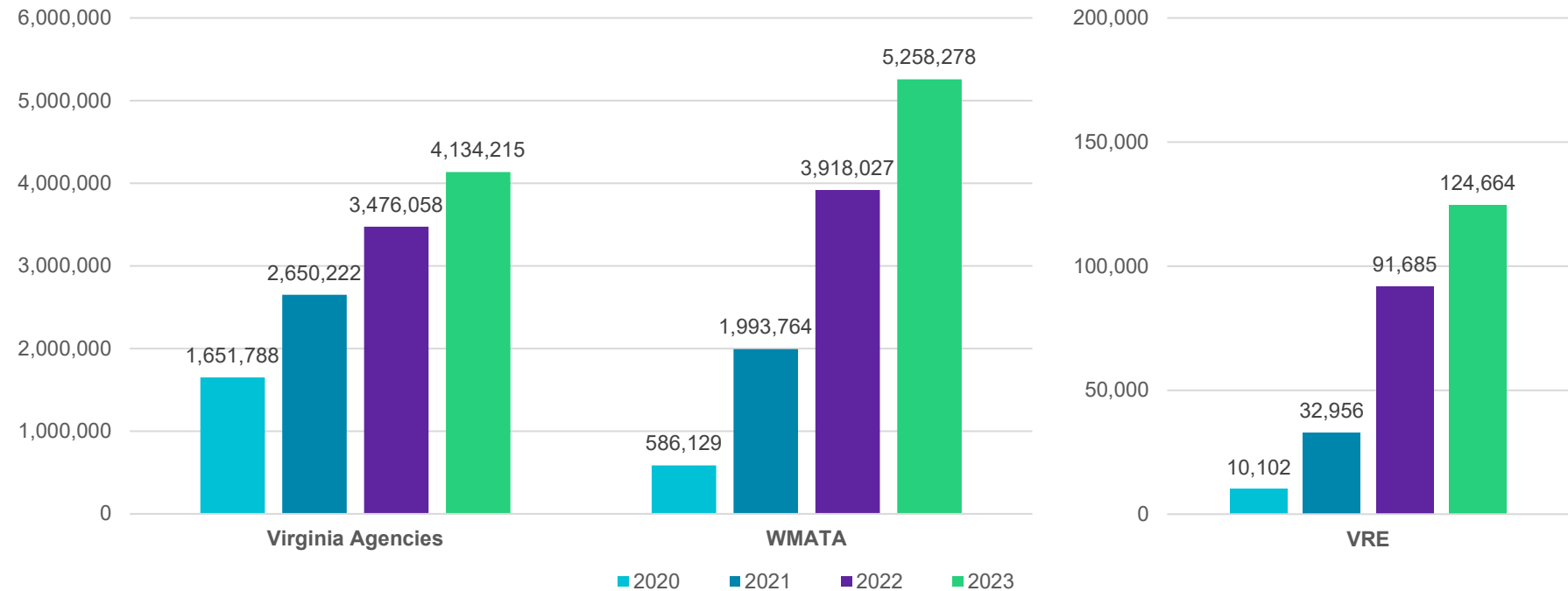

Mode	April 2020	April 2021	April 2022	April 2023	April 2023 vs 2020	April 2023 vs 2021	April 2023 vs 2022
Virginia Agencies	1,651,788	2,650,222	3,476,058	4,134,215	150%	56%	19%
VRE	10,102	32,956	91,685	124,664	1134%	278%	36%
WMATA	586,129	1,993,764	3,918,027	5,258,278	797%	164%	34%
All Agencies + VRE + WMATA	2,248,019	4,676,942	7,485,770	9,517,157	323%	103%	27%

Virginia Breeze Ridership - April

In April 2023, ridership on VA Breeze routes totaled 4,731 which was:

- 165% higher than original estimates
- 17% higher than April 2022

On-time-performance (OTP) was 78% and the overall farebox recovery was 42%

For the month of April 2023, the VA Breeze contributed to a reduction of 160 metric tons of CO₂ equivalent emissions.

Valley Flyer:

- Ridership – 19% higher than April 2022
- Farebox Rev. – 15% higher than April 2022

Piedmont Express:

- Ridership – 2% higher than April 2022
- Farebox Rev. – 3% higher than April 2022

Capital Connector:

- Ridership – 7% lower than April 2022
- Farebox Rev. – 6% lower than April 2022

Highlands Rhythm:

- Ridership – 31% higher than April 2022
- Farebox Rev – 30% higher than April 2022

Virginia Breeze Ridership by Route – May 2022 to April 2023

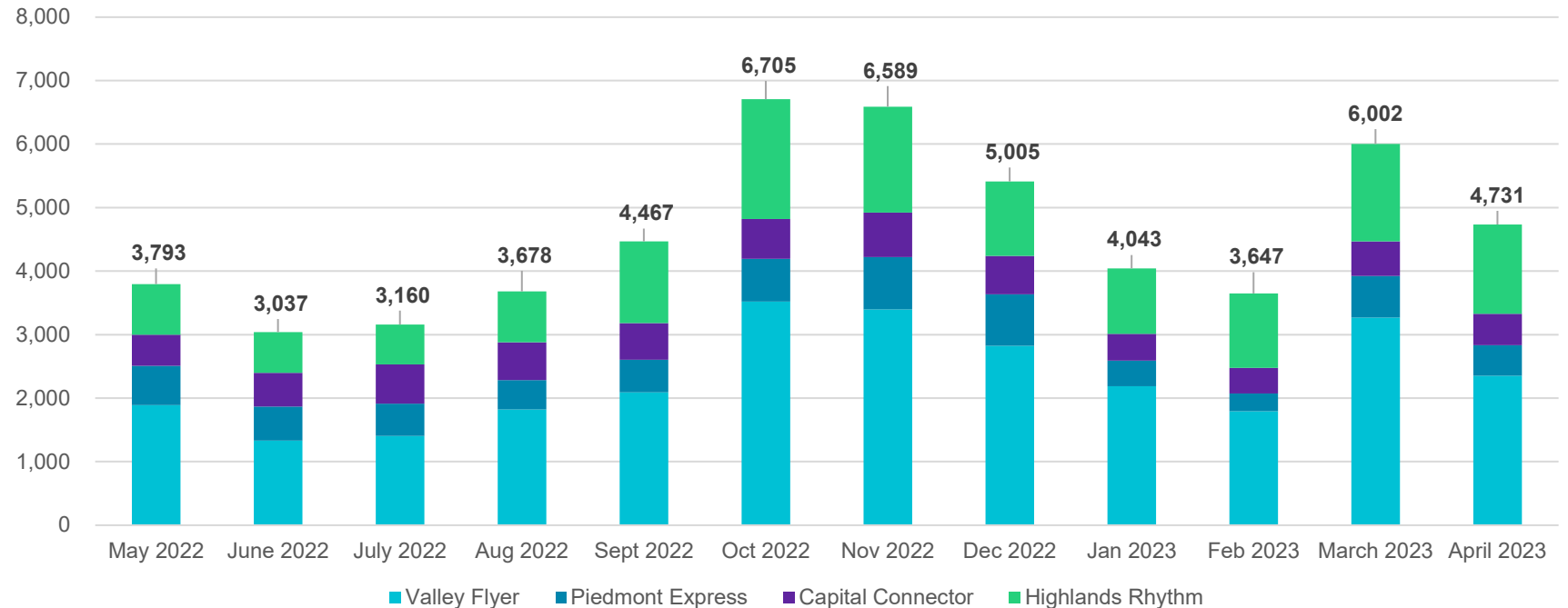

Route	May 2022	June 2022	July 2022	Aug 2022	Sept 2022	Oct 2022	Nov 2022	Dec 2022	Jan 2023	Feb 2023	March 2023	April 2023	Total
Valley Flyer	1,888	1,329	1,405	1,820	2,091	3,519	3,394	2,826	2,187	1,793	3,269	2,351	27,872
Piedmont Express	618	537	507	464	511	672	827	808	402	278	656	483	6,763
Capital Connector	490	533	621	597	581	627	701	606	421	404	544	493	6,618
Highlands Rhythm	797	638	627	797	1,284	1,887	1,667	1,171	1,033	1,172	1,533	1,404	14,010
All Routes	3,793	3,037	3,160	3,678	4,467	6,705	6,589	5,411	4,043	3,647	6,002	4,731	55,263

Virginia-Supported April Ridership by Route 2023 vs 2022

The largest year over year ridership increase was Route 47: Newport News at 81.3% (+13,426)

All four routes saw increased ridership year over year.

Route 46: Roanoke Ridership (+39.9%)

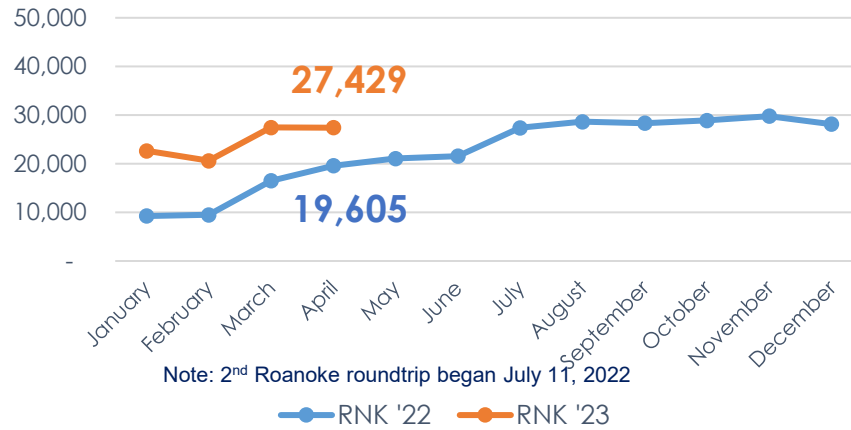

Route: 47 Newport News Ridership (+81.3%)

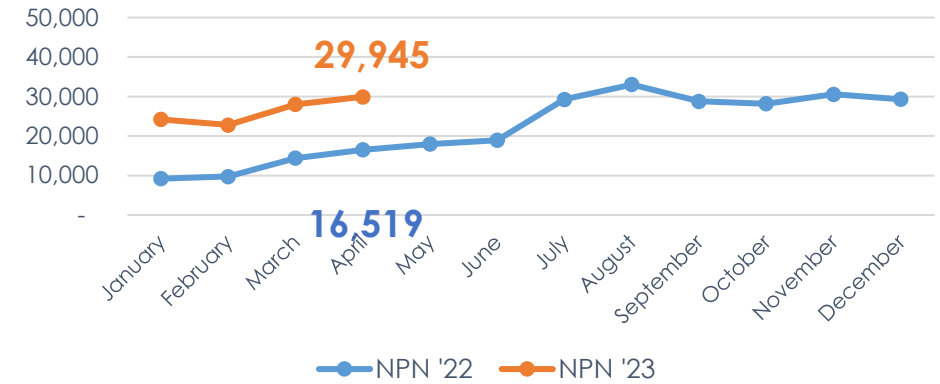

Route 50: Norfolk Ridership (+49.6%)

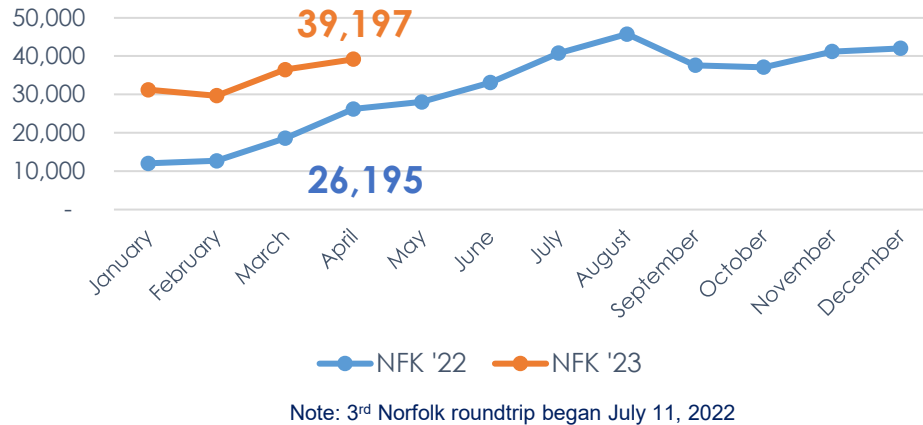

Route 51: Richmond Ridership (+40.0%)

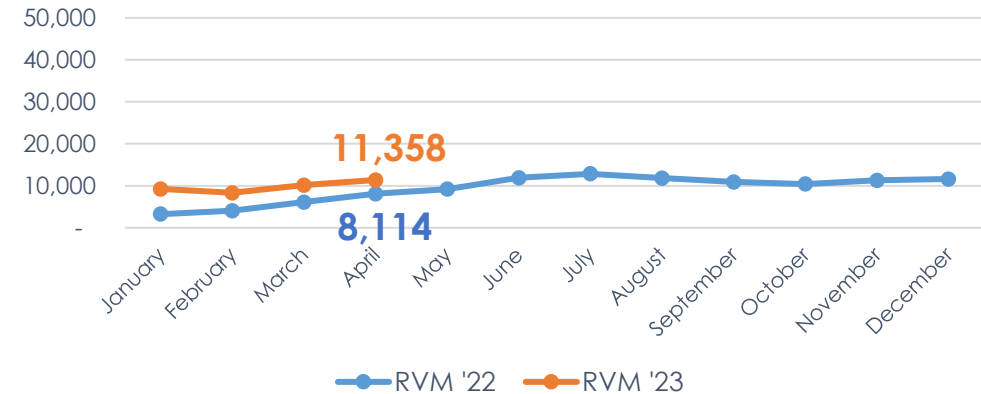

Note: Roanoke ridership for April subject to slight variance due to ongoing Amtrak allocation adjustments