



**House Bill 1551**  
**Overload and Overweight Vehicle Study**  
**Conducted by the Virginia**  
**Transportation Research Council**

*November 19, 2008 CTB Workshop*

*Gary Allen, Ph.D., Chief of Technology*

# HB 1551 Mandate

## **Calls for review of current fee structure for overload and overweight vehicles**

- To be conducted by VDOT, in consultation with DMV, and industry representatives
- To determine what, if any, additional fees should be associated with damage and additional maintenance costs

**VDOT Commissioner shall recommend legislation regarding the fee structure by December 1, 2008**

## Overweight Permits Issued FY08

Type	Number Issued	Permit Revenue	Avg.
Single Trip	75,500	\$1,647,000	\$22
Blanket	6,273	975,000	\$155
Tank Wagons <sup>a</sup>	53	42,400	\$800
Hydroexcavators	12	1,580	\$132
Exempt	10,551	0	0
Coal haul <sup>b</sup>	750	0	0
<b>Total</b>	<b>93,099</b>	<b>\$2,665,900</b>	

<sup>a</sup> Current fee is \$265 for tank wagons based on previous work done by the Research Council

<sup>b</sup> No permit fees charged; pay coal severance tax instead

# Engineering Principles, ESALs, and Bridge Stress & Strain

## Weight Matters!

Pavements

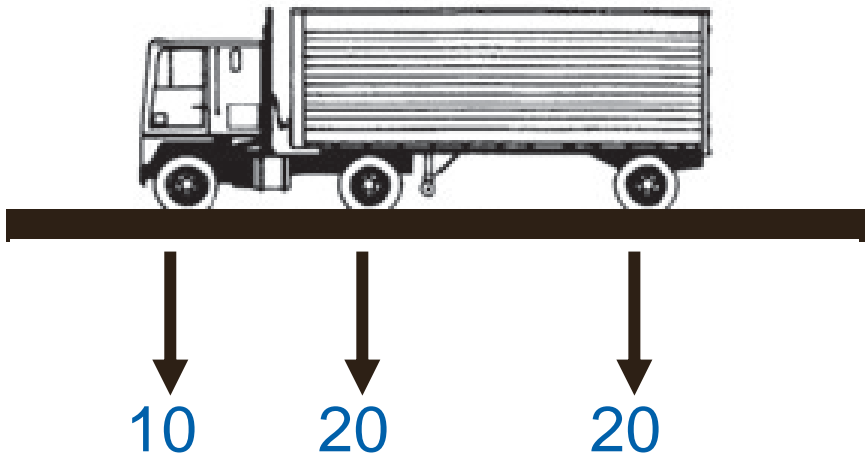

Bridges

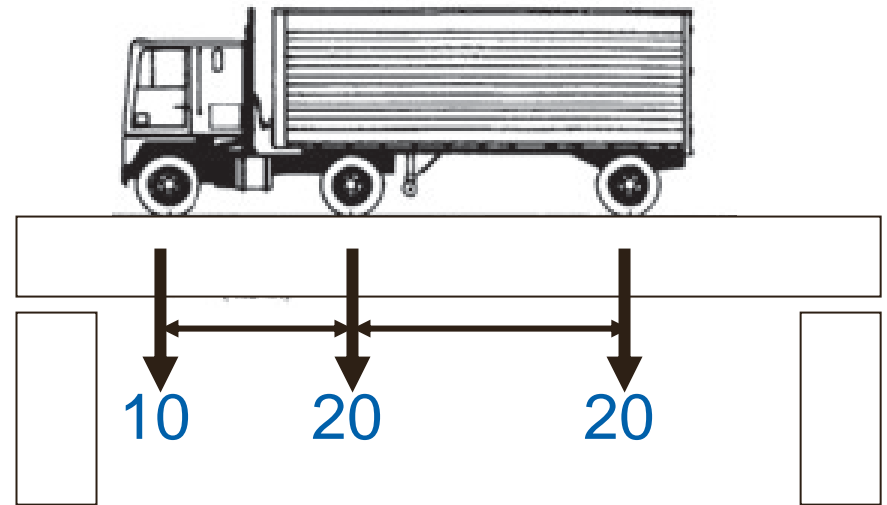

# Axle Weight Related Pavement Cost Analysis

## Methodology

- **Uses axle weights of all vehicles to determine cost per ESAL-mile traveled—VA weigh-in-motion data**
- **Accounts for miles trucks travel at less than full capacity**
- **Charges only for axle weights above standard legal weight limits**
- **Can be used to estimate the added maintenance cost from a single overweight trip or for blanket permits**

# Weight-Related & Axle Configuration Bridge Damage Cost Analysis

## Methodology

- **Incorporated VDOT Structure & Bridge Division permit calculation procedure for effects of truck weight and configuration on bridges**
- **Uses all DMV hauling permits issued for FY2008 as a base**
- **30,000 permits issued affect bridge deterioration and maintenance costs**

# Findings

- **Permit fees for overweight vehicles can be estimated based on sound engineering principles that relate axle weight and configuration to pavement and bridge deterioration**
- **For pavements, the fee is estimated to be 3.56 cents per ESAL-mile traveled for weights above the standard legal limit**
- **For a legally loaded tractor trailer, this equates to about 8 cents per mile but does not include any “common costs”.**
- **For bridges, the fee can be set based on a policy decision to recover either all or a portion of the damage cost per permitted trip**
- **An automated fee calculator has been developed to provide an easy way to examine fee alternatives**

# Sample Fee

## Single trip



Traveling I-81 NB  
 325 miles  
 58 bridges

Pavement Fee	\$37.16
Bridge Fee	\$105.51
Total	<u>\$142.67</u> <sup>a, b</sup>

<sup>a</sup> Does not include common costs

<sup>b</sup> Fees shown apply only to axle- or gross weight in excess of legal limits



# Sample Fee

## Blanket Permit



Good for 12 months  
 Estimated miles: 50,000  
 Bridges crossed: unknown

Pavement Fee	\$2000
Bridge Fee	<u>\$403</u>
Total	\$2403 <sup>a, b</sup>

<sup>a</sup> Does not include common costs

<sup>b</sup> Fees shown apply only to axle- or gross weight in excess of legal limits

# Results of the Analysis: Example Fees <sup>a, b</sup>

Truck	Pounds (000)		Len (Ft)	Dist (Mi)	Permit Fee	
	Permit	Legal			Current	Potential
5 Axle Tractor Truck	100	80	54	50000	\$165	\$3408
5 Axle Tractor Truck	92	80	48	50000	\$165	\$1896
3 Axle Dump Truck	60	46	22	10000	\$45	\$796
4 Axle Concrete Truck	70	58	25	10000	\$0	\$1158
7 Axle Tractor Truck	122	80	64	20	\$14	\$54
7 Axle Tractor Truck	132	80	78	335	\$46	\$150
7 Axle Tractor Truck	132	80	57	335	\$36	\$161
9 Axle Tractor Truck	168	80	92	335	\$50	\$217

<sup>a, b</sup> Does not include common costs and fees are only for axle- or gross weights in excess of legal limits

# Overweight Permit Fee Administration

- **For pavement damage fees:**
  - **Truck configuration and axle weights reported in permit applications now**
    - ESALS can be readily calculated from this
  - **Estimated mileage can be reported to DMV**
- **For bridge damage fees:**
  - **Truck configuration and axle weights reported in permit application now**
  - **VDOT Structure and Bridge calculates damage caused relative to standard design vehicle now**

# Policy Issues Related to Recommending An Overweight Permit Fee Structure

- **Should fees be based on pavement impacts, bridge impacts, or both?**
  - Permitted overweight load-related pavement impact is approximately \$180 million; for bridges, \$24 million
- **Reasonable fee during difficult economic times**
  - Very long haul permit fees could significantly increase shipping costs
- **Example exemptions presently in place**
  - Containerized freight—7400 permits
  - 2 or 3 axle solid waste—1100 permits
- **Revenue potential**
  - If all vehicles presently charged for permits paid fees equal to tank wagons, it would generate almost \$22 million;
  - If containerized cargo and solid waste paid, it would generate an additional \$2.25 million
  - A bracket scale of permit fees that accounted for long-haul blanket permits presently granted at very low amounts could easily generate \$30 to \$50 million depending on the fees charged.